

ROUGH TERRAIN VACUUM MOVE LIFTER - RT-VML-6-58

APPROX WEIGHT: 2575 lbs.
DOES NOT INCLUDE WEIGHT OF POWER OR PACKAGING!!!

*** ANY ADDITIONS, DELETIONS, OR OMISSIONS MUST BE CORRECTED ON THIS DRAWING AS THIS DRAWING WILL BE CONSIDERED ALL INCLUSIVE ***

ALL GRAPHICS PROVIDED ARE FOR REFERENCE ONLY. IF CERTAIN DIMENSIONS ARE CRITICAL PLEASE VERIFY THOSE DIMENSIONS WITH YOUR SALESPERSON

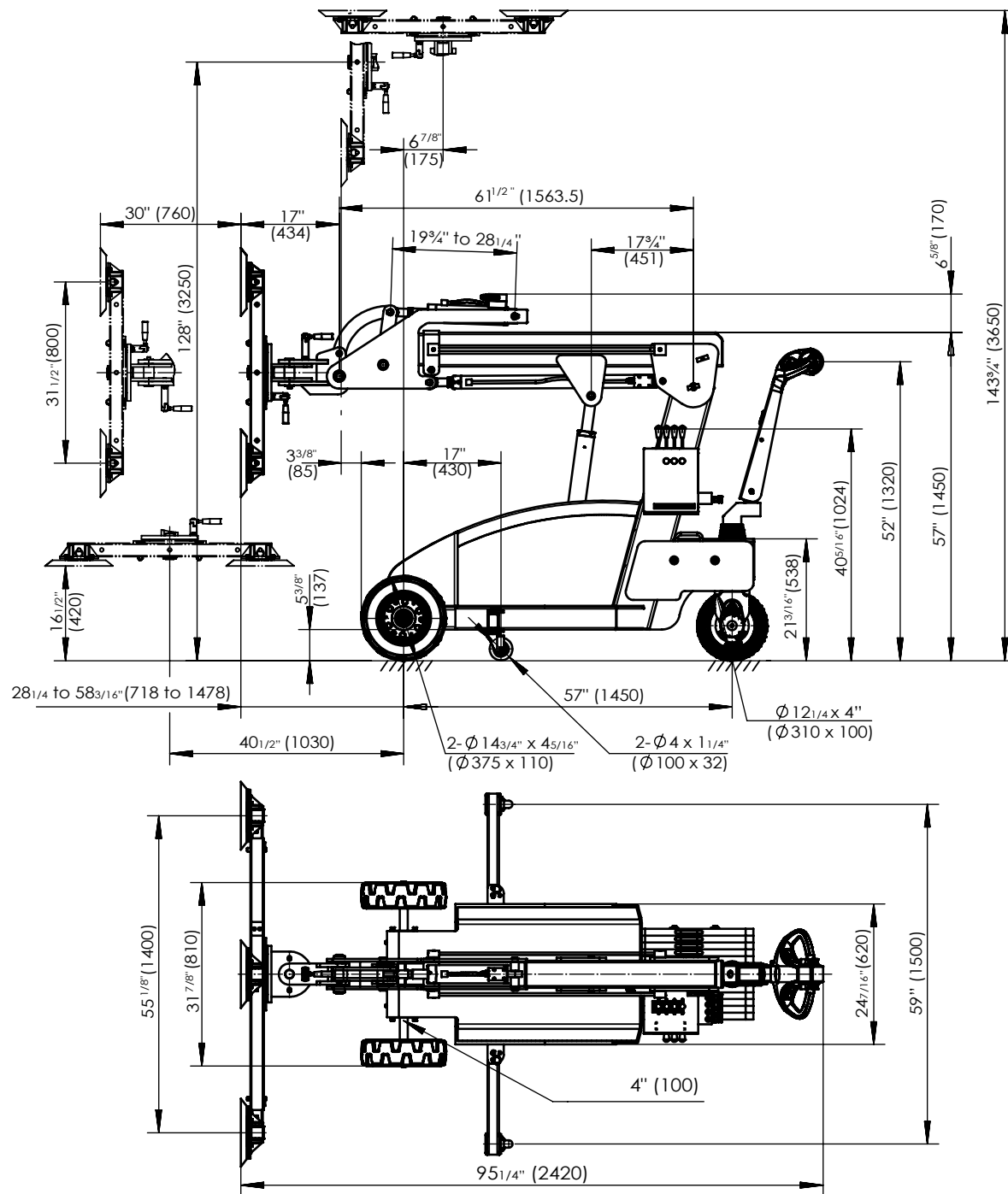

STANDARD FEATURES

- MODEL NO: RT-VML-6-58
- MAXIMUM CAPACITY (RETRACTED): 1200 LBS
- MAXIMUM CAPACITY (EXTENDED): 600 LBS
- DRIVE MOTOR: 24V DC / 0.9 KW
- LIFT MOTOR: 24 V DC / 2.0 KW
- LIFT SPEED (LOADED): 0.70" / SEC
- LIFT SPEED (UNLOADED): 0.50" / SEC
- LOWER SPEED (LOADED): 0.74" / SEC
- LOWER SPEED (UNLOADED): 1" / SEC
- TRAVEL SPEED (LOADED): 1.8 MPH
- TRAVEL SPEED (UNLOADED): 2.4 MPH
- BATTERY: 2x 12V / 85-95 Ah
- BATTERY CHARGER: 24V / 12amp
- TOUGH BAKED IN POWDER COATED BLACK & YELLOW FINISH

SPECIAL FEATURES

NONE

DIMENSION TOLERANCE ± 1/2"

APPROVAL

I, THE UNDERSIGNED, AGREE THAT THE PRODUCT AS REPRESENTED SATISFIES DESIGN AND DIMENSION REQUIREMENTS. I ALSO ACKNOWLEDGE MY DUTY TO CONFIRM PRODUCT AND INSTALLATION COMPLIANCE WITH ALL APPLICABLE FEDERAL, STATE AND LOCAL REGULATIONS AND STANDARDS.

UNITS REQUIRING APPROVAL DRAWINGS OR MODIFIED ARE NON-RETURNABLE

As drawn As marked

Signed: _____ Date: _____

Printed Name: _____

LEAD TIME WILL START UPON RECEIPT OF SIGNED APPROVAL DRAWING

DISTRIBUTOR'S NAME:		P.O.#
VESTIL MANUFACTURING		X
DRAWN BY: TM		DATE: 2/5/2021
REFERENCE: X		SALES: X
QUOTED LEAD TIME: X		SCALE: NTS
QUOTE # X		FILE NAME: RT-VML-6-58