



ELITE
S E R I E S

LAVINA ELITE
L25LEB/L25LEHVB
User Manual



Support Line: 800-987-8403 | www.superabrasive.com | info@superabrasive.us



Warranty Registration Card

Complete and submit this form within 30 days from the date of purchase. The registration is invalid without the machine serial number.

Section 1: Customer Information

Customer name

Address

City

State and Zip Code

Phone #

Email

Section 2: Machine Information

LAVINA model

Serial #

Purchase Date

Purchased From (distributor, dealer)

Email: warranty@superabrasive.us / Fax: 706-658-0357
Superabrasive Inc., 9411 Jackson Trail Rd, Hoschton, GA 30548

WARRANTY AND RETURNS

WARRANTY POLICY FOR LAVINA® ELITE MACHINES

A warranty card must be submitted to Superabrasive within 30 days of purchase in order for the foregoing warranty to apply.

You can either mail a hard copy of the warranty card or submit it electronically - see page 2.

Superabrasive warrants, from the time of delivery and receipt by the original customer, new and unused products sold by Superabrasive or Superabrasive-appointed distributors or dealers. Goods shall be free from defects in materials and workmanship. Superabrasive or a Superabrasive-appointed repair facility shall either replace or repair any defects in the Goods resulting from faulty design, materials, or workmanship. Products repaired or replaced during the warranty period shall be covered by the foregoing warranty for the remainder of the original warranty period, or ninety (90) days from date of the repair or shipment of the replacement, whichever is longer. Spare parts for repair will be either new or equivalent to new.

Warranty period shall be 2 years from the time of delivery and receipt by the original customer, or 600 operating hours on the machine - whichever occurs first. Superabrasive will cover the shipping charges for the transportation of the machine to Superabrasive (or an approved repair facility) and back to the customer (within the contiguous 48 United States) in the event that the damage occurs and is reported within 200 operating hours. Shipping charges, if covered by Superabrasive, must be agreed upon in advance and approved by Superabrasive. Thereafter, the customer will have to cover the shipping charges to Superabrasive and back. Superabrasive will not warranty Goods after a period of 2 years from the time of delivery and receipt by the original customer, or 600 operating hours on the machine - whichever occurs first.

Superabrasive shall not be liable for any defects that are caused by circumstances that occur after the Goods have been delivered and whilst the Goods are in the possession of the purchaser. Furthermore, the warranty does not include normal wear and tear or deterioration. Wear parts are not warranted. Superabrasive is not liable for defects arising out of use of non-OEM parts.

The Warranty is void if the purchaser has not followed the maintenance plan stipulated by the machine's manual and warranty card. The warranty is void if the purchaser repairs said Goods himself, or if repairs are conducted by a repair facility that is not approved by Superabrasive. Superabrasive's liability does not cover defects which are caused by faulty maintenance, incorrect operation, faulty repair by the purchaser, or by alterations conducted without Superabrasive's prior written consent. The same applies to any alterations of the Goods or services performed by another party other than Superabrasive, a Superabrasive-appointed distributor, or a Superabrasive-approved repair facility. The warranty is not applicable on a defect that arises due to tools or parts that are not original to Superabrasive. Replaced defective parts shall be placed at Superabrasive's disposal and shall become property of Superabrasive. If such defective parts are replaced

within the warranty period, the shipping charges will be covered by Superabrasive. In warranty complaint cases, when no defects are found for which Superabrasive is liable, Superabrasive shall be entitled to compensation for the labor, material cost, and shipping charges, incurred by Superabrasive as a result of the complaint.

The warranty herein is non-transferable, and only applies to the original owner or purchaser of the machine.

RETURN POLICY FOR LAVINA® ELITE MACHINES

The Lavina® ELITE machines may be returned, subject to the following terms:

In no case, a machine is to be returned to Superabrasive Inc. for credit or repair without prior authorization. Please contact Superabrasive Inc. or your local distributor for an authorization and issuance of a return authorization number. This number along with the serial number of the machine must be included on all packages and correspondence. Machines returned without prior authorization will remain property of the sender and Superabrasive Inc. will not be responsible for them. No machines will be credited after 90 days from the date of invoice.

All returns must be shipped freight prepaid. Returned machines may be exchanged for other equipment or parts of equal dollar value. If machines are not exchanged, they are subject to a fifteen percent (15%) restocking fee.

1. GENERAL INFORMATION.....	5	WATER LEAKS	16
1.1 MANUFACTURER.....	5	MECHANICAL PARTS	16
1.2 GENERAL DESCRIPTION	5	8. TROUBLESHOOTING	17
1.3 ENVIRONMENTAL CONDITIONS	5	INDEX OF PROBLEMS AND SOLUTIONS	17
1.4 VACUUM CONNECTION.....	5	8.1 SEPARATING THE HEAD FROM THE CARRIAGE	17
1.5 LAVINA® LEB/ LAVINA® LEHVB MAIN COMPONENTS	5	8.2 DISMOUNTING/MOUNTING THE GUARD	19
1.6 TECHNICAL DATA	7	8.3 REPLACING POWER CORD AND PLUGS.....	19
1.7 VIBRATIONS.....	7	8.4 DISMOUNTING AND MOUNTING TOOL HOLDER TO CHANGING V-RINGS AND FELT-RINGS.....	19
2. SAFETY INSTRUCTIONS.....	7	8.5 DISASSEMBLING AND MOUNTING TOOL HOLDER TO CHANGE BUFFERS AND ELASTIC ELEMENT	20
RECOMMENDED USE	7	8.6 CORRECTING DEFLECTION OF THE USED PLANETARY CHAIN.....	21
PROHIBITED USE.....	7	MOUNTING NEW PLANETARY CHAIN	21
PROTECTION DEVICES	8	8.7 REPLACING THE PLANETARY DRIVING CHAIN WHEEL AND PLANETARY TENSIONER	22
ARREST FUNCTIONS.....	8	8.8 TENSIONING AND REPLACING THE BELTS.....	23
SAFE USE	8	8.9 REPLACING THE DRIVEN PLANETARY GEAR (SPROCKET).....	25
RESIDUAL RISKS.....	8	8.10 REPLACING THE PULLEY UNITS.....	25
BEFORE YOU BEGIN	8	8.11 REPLACING THE PLANETARY UNIT.....	26
OPERATING MACHINE	8	8.12 MOTOR CONNECTION	26
THE WORK AREA.....	8	8.13 FAULT DIAGNOSIS INVERTER YASKAWA V1000	27
PERSONAL PROTECTIVE	8	9. DISPOSAL.....	29
EQUIPMENT (PPE).....	8	10. MANUFACTURER'S CONTACTS.....	29
3. HANDLING AND TRANSPORTATION	9	11. SPARE PARTS.....	30
3.1 ADJUSTING THE HANDLE	9	11.1.GENERAL PARTS	30
3.2 TURNING THE MACHINE FROM WORKING TO TOOL MOUNTING POSITION.....	9	11.2 BUMPER.....	30
3.3 LIFTING	10	11.3. TOP COVER 1 PARTS	31
3.4 STORAGE	10	11.4 GUARD ASSEMBLY.....	31
4. OPERATION	10	11.5 TOP COVER ASSEMBLY	31
4.1 PRELIMINARY CONTROLS	10	11.6. BOTTOM COVER 1 PARTS	32
4.2 WATER FLOW CONTROL SYSTEM.....	11	11.7 PLANETARY DRIVE PARTS	33
4.3 ADJUSTING AND MOUNTING TOOLS	12	11.9. BOTTOM COVER 2 PARTS	34
4.4 VACUUM CONNECTION.....	12	11.10. TOOL HOLDER PARTS.....	34
4.5 CONTROL BOARD	13	11.11 CARRIAGE PARTS 1	35
4.6 STARTING THE MACHINE.....	13	11.12 CARRIAGE PARTS 2	36
4.7 OPERATING THE MACHINE	13	11.13. CARRIAGE PARTS 3	36
4.8 STOPPING THE MACHINE.....	13	11.14 WHEEL ASSEMBLY.....	37
5. TOOLS AND ACCESSORIES	14	11.15. WATER TANK.....	37
TOOL HOLDER KEY	14	11.16 EXTERNAL WATER VALVE.....	37
SECURITY PLATE FOR QUICKCHANGE PADS	14	11.18 LAVINA 25LEB CONTROL BOX PARTS 200-240 V.....	39
6. POPULAR TOOLS	15	11.19 LAVINA 25LEHVB CONTROL BOX PARTS 400-480 V	40
7. MAINTENANCE AND INSPECTION	16	11.20 ELECTRICAL SYSTEM.....	41
CLEANING.....	16		
CHECK DAILY.....	16		
CHECK EVERY 200 WORKING HOURS.....	16		
CHECK EVERY 400 WORKING HOURS.....	16		
VACUUM	16		

1. GENERAL INFORMATION

This owner's manual is intended for the operator of the **LAVINA® LEB/ LAVINA® LEHVB** machine, the servicing technician as well as for anyone involved with operating or servicing the machine. We recommend that you read the instructions very carefully and follow them strictly. The manual includes information about assembling, using, handling, adjusting and maintaining your **LAVINA® LEB/ LAVINA® LEHVB** floor grinding and polishing machine.

1.1 MANUFACTURER

Superabrasive was founded in 1987, as a manufacturer of high quality diamond tools for the stone and concrete industry. Today, Superabrasive is one of the world's leading companies in the production of diamond tools and floor grinding machinery. At Superabrasive, we strive to deliver the very best solutions to our customers, and enable them to work more efficiently.

1.2 GENERAL DESCRIPTION

The **LAVINA® LEB/ LAVINA® LEHVB** machine is intended for grinding, polishing and buffing concrete, marble, granite, limestone and terrazzo surfaces with diamond tools. Additionally, the machine could be used for grinding wood floor surfaces.

The **LAVINA® LEB/ LAVINA® LEHVB** machine is a three-disc machine, which can be used wet or dry.

For best results, use only tools manufactured or recommended by Superabrasive and its distributors.



The **LAVINA® LEB/ LAVINA® LEHVB** machine is manufactured and fitted for the above-mentioned applications only! Every other use may possess risks to the persons involved.

1.3 ENVIRONMENTAL CONDITIONS

The temperature range for operating the **LAVINA® LEB/ LAVINA® LEHVB** machine outdoors is between 41°F and 86°F or 5°C and 30°C. Never use the **LAVINA® LEB/ LAVINA® LEHVB** machine during rain or snow when working outdoors. When working indoors, always operate the machine in well-ventilated areas.

1.4 VACUUM CONNECTION

A connection for a vacuum dust extractor is located on the carriage. The **LAVINA® LEB/ LAVINA® LEHVB** machine does not include a vacuum dust extractor. The customer must purchase the vacuum dust extractor separately. The vacuum dust extractor must be adapted for floor grinders and have a minimum air displacement of 310m³/h with a negative vacuum of 21 kPa.

1.5 LAVINA® LEB/ LAVINA® LEHVB MAIN COMPONENTS

The **LAVINA® LEB/ LAVINA® LEHVB** machine is made of two main component sections:

1.5.1 Carriage which contains:

- **Handle - the handle** on the frame is adjustable in height and allows the operator to work in a correct and safe posture (see point 3. Handling and transportation).
- **LED lights - the LED lights** (Fig.1.1; Fig.1.2) enables the operator to work in darker areas. Existing lighting system does not replace adequate overhead lighting.
- **The control panel** (fig.1.3) is positioned on top of the frame and contains buttons and switches for start/stop the machine also for the , lights, RPMs control switch, hour meter unit, EMG button and the USB port for charging your phone.
- **The water tank** is on the opposite side of the frame, so that the weight of the water does not affect the operation of the machine. The frame weight, on the other hand, is fully absorbed by the driving wheels. An electric pump sprays the water through a front mist system or internal under cover.
- **Power box**
- **Water pump**

1.5.2 Machine head which contains:

- **The Electric motor** - its mounted on the base plate and it is driving the three heads with a belt system.
- **The planetary motion** - it derives from the main engine, driven by a simplex roller chain.
- **The self-leveling Guard** is designed to have contact with the surface. Anytime, no matter the height of the tool used.
- **“Quickchange” tool holder** is designed to hold the tools with “Quickchange” connection (All of our new tools use the “Quickchange” connection and there is no more foam holders).



Figure 1.1



Figure 1.2



Figure 1.3

1.6 TECHNICAL DATA

	Lavina® 25LEB		Lavina® 25LEHVB	
Voltage/Hz	3 ph x 200-240V 50-60Hz		3 ph x 400-480V 50-60Hz	
Amperage	Max 45 Amps		Max 30 Amps	
Power	11 kW	15 HP	11 kW	15 HP
Tool holder rpm	400-1100 rpm		400-1100 rpm	
Direction off rotation	The heads have clockwise / right rotation		The heads have clockwise / right rotation	
Working width	655 mm	25.8"	655 mm	25.8"
Tool diameter (QC Plate)	3x 225 mm	3x 9"	3x 225 mm	3x 9"
Weight	380 kg	838 lbs	380 kg	838 lbs
Grinding pressure Weights upward	201 kg	443 lbs	201 kg	443 lbs
Grinding pressure Weights downward	237 kg	522 lbs	237 kg	522 lbs
Application	wet and dry		wet and dry	
Vacuum hose port	Cam lock E250		Cam lock E250	
Water tank capacity	20 l	5.2 gal	20 l	5.2 gal
Water feed	Peripheral		Peripheral	
Cable length	17.4 m	57 ft	17.4 m	57 ft
Machine LxWxH	1430x617x1214 mm	56x24.3x47.8"	1430x617x1214 mm	56x24.3x47.8"
Packing LxWxH Crate 1	1480x840x1454 mm	58.3x33x57.2"	1480x840x1454 mm	58.3x33x57.2"

1.7 VIBRATIONS

The vibrations of the machine are within the limits of directives and harmonized standards from the European Union when the **LAVINA® LEB/ LAVINA® LEHVB** is operated with the recommended tools and in normal conditions.

SONOROUS EMISSIONS

The sonorous emissions are within the limits of directives and harmonized standards from the European Union when the **LAVINA® LEB/ LAVINA® LEHVB** is operated with the recommended tools and in normal conditions. However, as previously stated, the operator must wear ear protectors.

LABEL DATA

The data on the label provides the correct Voltage and kW (needed for operational purposes);

Weight (needed for transportation purposes); production year and serial number (needed for maintenance purposes).

CUSTOMER SERVICE

For customer assistance and technical support call your local distributor or call Superabrasive Inc. at 1-800-987-8403 or visit us at: www.superabrasive.com, where you can download a copy of this manual.

2. SAFETY INSTRUCTIONS

RECOMMENDED USE



The **LAVINA® LEB/ LAVINA® LEHVB** machine is designed and manufactured to grind and polish concrete, terrazzo, and natural stone floors. It can be used for renovation as well as for polishing. The machine is designed for dry or wet use. When using it dry, use a vacuum of appropriate size. For more information, please refer to the chapter on handling the vacuum connection.

PROHIBITED USE



The machine MUST NOT be used:

- For applications different from the ones stated in the general description chapter.
- For non-suitable materials. In environments which:
 - Possess risks of explosion,

WARNING

- Possess high concentration of powders or oil substances in the air,
- Possess risks of fire Feature inclement conditions,
- Possess electromagnetic radiation.

Preparation for work



Make sure that:

- You have closed the work area, so that no person unfamiliar with operating the machine can enter the area.
- The tool plate and tools are adjusted to the machine properly.
- There are no missing parts of the machine
 - The machine is in upright working position.
 - The protection devices are working properly.
 - The electrical cable is free to move and follow the machine

- Superabrasive easily.
- In order to keep the electrical cable from being damaged, no vehicle should cross the zone where electrical cables are situated.

PROTECTION DEVICES  **WARNING**

The machine is equipped with several protection devices including the following:

- An emergency stop button
- A protection skirt and a hood for protecting the tool plates.

These devices protect the operator and/or others persons from potential injuries. Do not remove them. Before using the machine, please ensure that all protection devices are mounted and function properly. The Security plate prevents the QuickChange pads to from loosening during work

ARREST FUNCTIONS  **WARNING**

Methods of arresting of the machine are following:

- Button to stop the motor (category 1)
- Emergency button (category 1)

SAFE USE

The **LAVINA® LEB/ LAVINA® LEHVB** is designed to reduce risks correlated with its use. However, it is not possible to fully eliminate the risks of an accident with the machine. An unskilled or uninstructed operator may cause correlated residual risks. Such risks are:

- Position Risks: due to operator’s incorrect working position
- Entanglement Risks: due to wearing inappropriate working clothes
- Training Risks: due to lack of operational training.
- **NOTE:** In order to reduce any consequences of the above-mentioned risks, we advise that machine operators follow the instructions in the manual at all times.

RESIDUAL RISKS  **WARNING**

During the normal operating and maintenance cycles, the operator is exposed to some residual risks, which cannot be eliminated due to the nature of the operations.

BEFORE YOU BEGIN  **WARNING**

- Working area must be clear from any debris or objects.
- A first-time operator must always read the manual and pay attention to all safety instructions.
- All electric connections and cables must be inspected for potential damages.
- Ground wire system of the power supply must be also inspected.
- Perform general daily inspections of the machine and inspect the machine before each use.
- Always inspect the safety devices: Mount the Security plate for the QuickChange pads.
- The emergency break must be clear and working
- The tool protector must be working
- The machine must be clean ☐ Never operate the machine in the rain!
- Confirm that there are no missing parts especially after transportation, repair or maintenance.

- Before filling the water tank with water make sure the machine is not working and the main switch is turned off.
- Before turning on the machine make sure that the base is placed on the floor, the machine **MUST NOT** be in an upright position when turned on!

 **WARNING**

OPERATING MACHINE

When operating the **LAVINA® LEB/ LAVINA® LEHVB**, make certain that there is no one but you around the machine.

Never leave the machine unattended while working. The electrical cable must move freely and must be damage- free. The water hose must move freely and must be damage-free. Check to make sure the floor you are preparing to work on is even. If the floor is uneven, it may damage the machine.

After Work is completed

- Clean the machine and its surroundings properly
- Empty and clean the water tank
- Unplug the machine and wind up the electrical cable
- Store the machine in a safe place

THE WORK AREA  **WARNING**

- Ensure that people or vehicles do not enter the work area.
- Clear any cables or hoses from the work area.
- Always check the floor for debris.

PERSONAL PROTECTIVE  **WARNING**

EQUIPMENT (PPE)

- Always wear safety shoes when working with the machine.
- Always wear ear protectors when working with the machine.
- All personnel in the immediate work area must wear safety glasses with side shields.
- Always wear safety gloves when changing the tools.
- Always wear clothes suitable for the work environment.

Operator  **WARNING**

The operator must know the machine’s work environment. Only one operator can work with the machine at a time. The operator must be properly trained and well-instructed prior operating the machine.

- The operator must understand all the instructions in this manual.
- The operator must understand and be able to interpret all the drawings and designs in manual.
- The operator must know all sanitation and safety regulations pertaining to the operation of the machine ☐ The operator must have floor grinding experience.
- The operator must know what to do in case of emergency.
- The operator must have adequate technical knowledge and preparatio

3. HANDLING AND TRANSPORTATION

3.1 ADJUSTING THE HANDLE

The Handle on the frame is adjustable in height and allows the operator to work in a correct and safe posture (Fig. 3.1, Fig. 3.2, Fig. 3.3, and Fig.3.5). Choose the upright position to move easy the machine.



Figure 3.2



Figure 3.3



Figure 3.4

3.2 TURNING THE MACHINE FROM WORKING TO TOOL MOUNTING POSITION

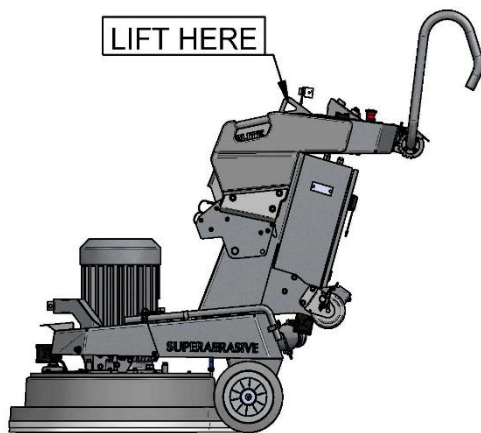

Figure 3.5

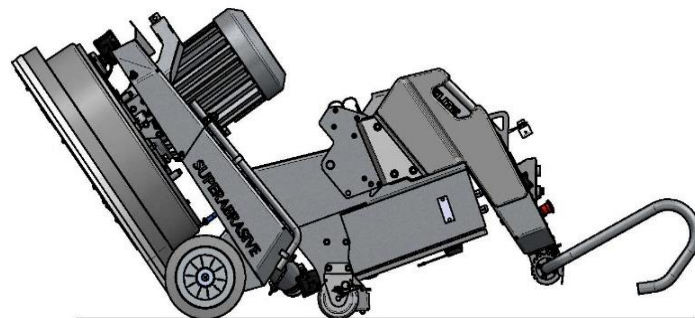

Figure 3.6

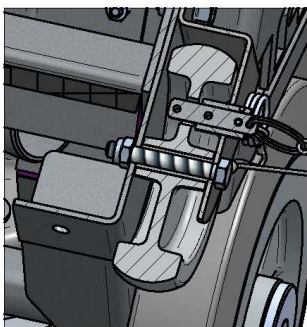

Figure 3.7

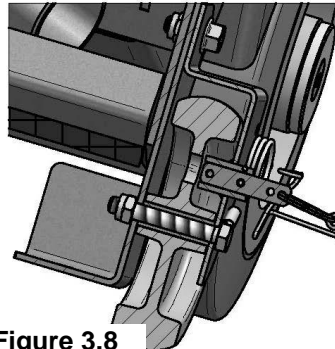

Figure 3.8

Put the handles of the carriage as shown on (Fig. 3.5). Ensure that the water tank is empty before flipping the machine. Push the handles and flip in position shown on (Fig. 3.6). If necessary, help by placing your foot on the heel near the control box. Always keep both rear wheels locked (Fig. 3.7). Unlock the wheels (Fig. 3.8) only when you wish to move the machine.

3.3 LIFTING

Lifting the machine by crane is possible by using the handles of the carriage (see fig. 3.5 and fig. 3.6). Do not lift any other loads on the machine. Always use hoisting equipment rated for 350 kg (772 lbs) or greater.

3.4 STORAGE

Always store the **LAVINA® LEB/ LAVINA® LEHVB** machine in a dry place. Never transport the **LAVINA® LEB/ LAVINA® LEHVB** machine unprotected; it may be damaged if transported unprotected and exposed to rain or snow.

 **WARNING** When the machine is in storage and the temperature may fall down to or below 32F (or 0° C). You should empty the water from the system:

- Leave open internal and external valves to drain water

4. OPERATION

4.1 PRELIMINARY CONTROLS

Inspect the working area as explained in the safety instructions. Fill in the water tank for wet use or connect the vacuum extractor and ensure that the vacuum hose is clear and it will follow the machine easily.

Make sure that the electrical motor is connected with the power box and then you can connect the power cable with the electricity and start the machine.

4.2 WATER FLOW CONTROL SYSTEM

The water system is designed to supply water directly on the tools. The water supply is coming either from the tank or from external water source:

- water supply from the tank:

Put the internal water valve into position „ON” (along the axis of the machine) Figure 4.2 and close the external valve Figure 4.3, so the water could flow from the tank through the internal valve over the tools. You can adjust the water flow by putting the internal valve in an intermediate position.

- external water supply:

Put the internal water valve into position „OFF” Figure 4.1 and open the external valve Figure 4.4, so the water could flow through the external valve over the tools. You can adjust the water flow by putting the external valve in an intermediate position.

ALWAYS USE CLEAN WATER TO PROTECT THE SYSTEM FROM DIRT.

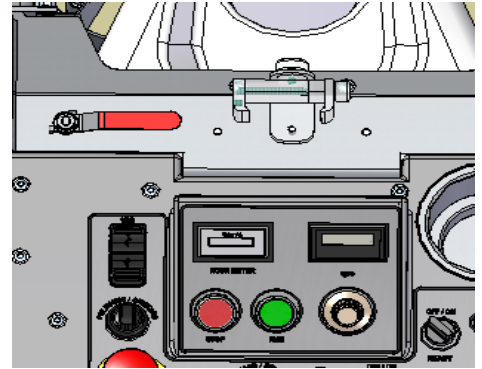

Figure 4.1

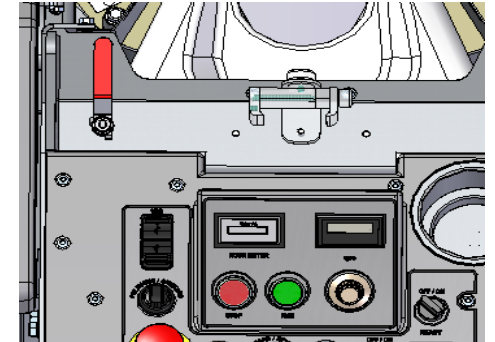

Figure 4.2

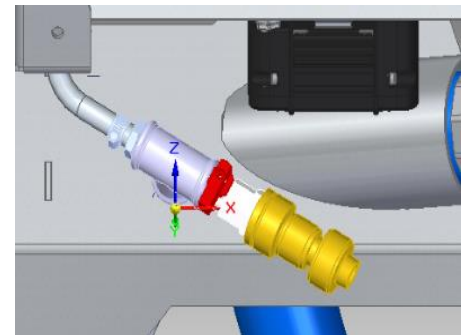

Figure 4.3

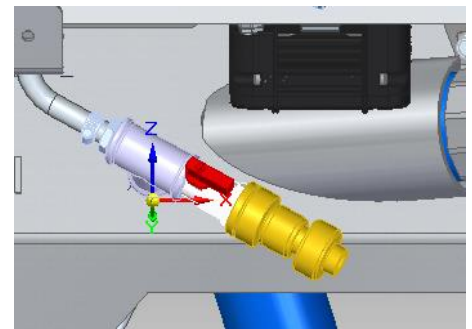

Figure 4.4

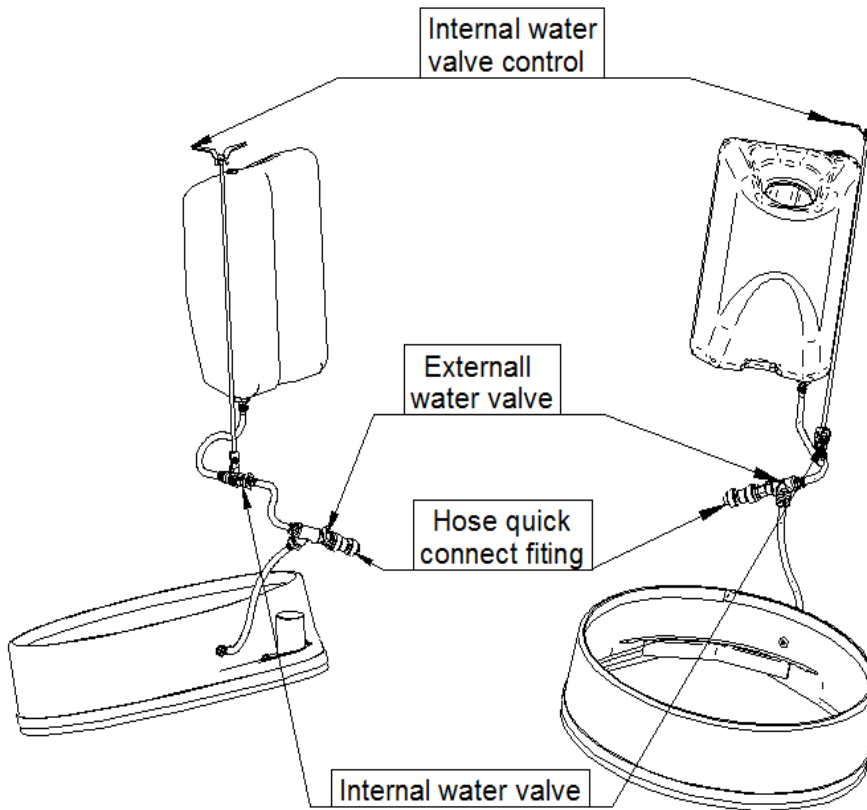

Figure 4.5

4.3 ADJUSTING AND MOUNTING TOOLS

LAVINA® LEB/ LAVINA® LEHVB uses tool holder A64. With this new holder every one of our tools uses the “Quickchange” connection. To change the tools you need first to unlock the butterfly (fig 4.6 in blue) by using the key we provide you (you can see it in the pictures fig. 4.7) remove the security plate (fig 4.6 in red) then load the tools you want and insert the security plate again so the tools cannot go backwards, rotate and lock the butterfly (as shown in fig.4.7). As you can see in fig. 4.6, for some of the new tools you need to remove the security plate as they don't need locking system at all but for the others always make sure that the tools are securely locked.

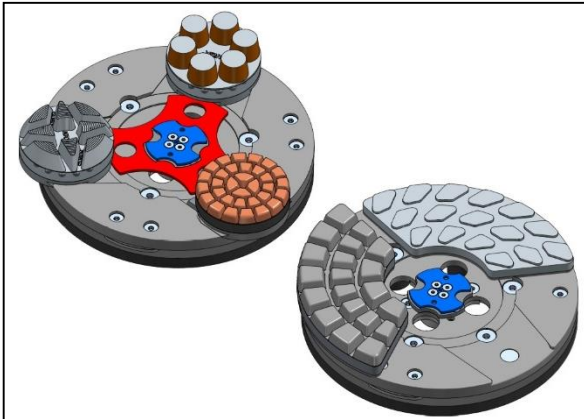

Figure 4.6

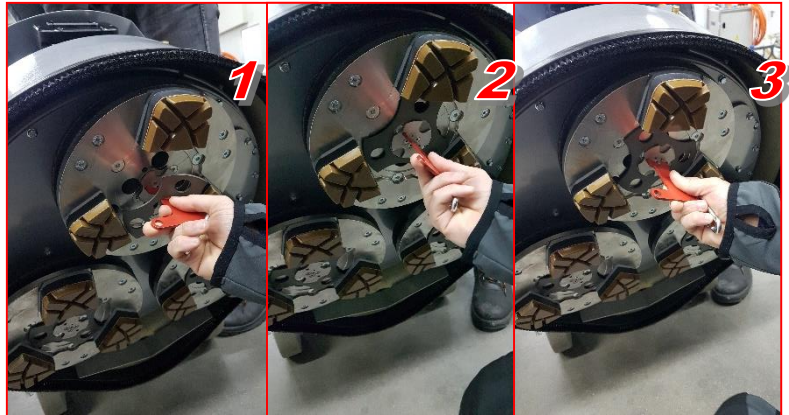

Figure 4.7

In LAVINA® LEB/ LAVINA® LEHVB the holder is initially mounted with 3 buffers.

Mount the tools only after ensuring that there is enough diamond bond material left. Be sure that the plates are always clean before mounting.

WARNING: Always secure the Quick Change tools with the butterfly (Fig.4.6 in blue), lock with the tool holder key (Fig.4.7) and make sure that the butterfly is securely locked and it holds the security plate not to fall off.

4.4 VACUUM CONNECTION

To connect a vacuum cleaner, the **LAVINA® LEB/ LAVINA® LEHVB** is supplied with vacuum hose Cam Lock inlet C250 / vacuum hose diam. 2, 5 in (63mm) (Fig.4.8).

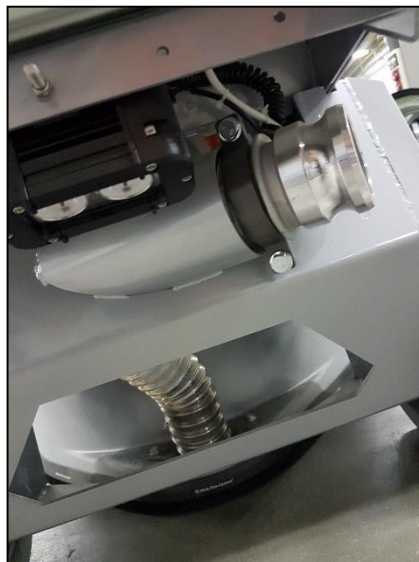

Figure 4.8

4.5 CONTROL BOARD

1. Hour Meter

2. USB charger.

3. EMERGENCY button used to stop the motor in case of emergency.

4. POWER glowing button - it glows when the machine is connected to the electricity.

5. Forward/Reverse switch. Select forward for clockwise rotation of the grinding plates or reverse for counterclockwise rotation of the grinding plates (recommended configuration). The preferred operating direction should be when the switch is in the forward position. The proper direction of rotation of the motor (counterclockwise) is indicated by an arrow on its cover.

6. ALARM/Reset button resets the alarm of the inverter. Button lights blue when the inverter goes into alarm mode.

7. LED lights switch

8. QR code. When you scan it with your phone for example, it will redirect your browser to Lavina manuals page.

9. READY ON / OFF switch. If you want to start the motor it must be ON as it puts the inverter into standby mode (it glows when it's turned ON). If it's off the inverter will be out of standby mode and you cannot start the motor. The switch returns to its starting position after being released.

10. Cup holder.

11. Potentiometer. Controls the RPM of the grinding plates in a range of 300-1100 rpm.

12. RUN button. Start the motor (ready ON/OFF switch must be ON).

13. Digital Tachometer. Indicates the revolution per minute of the grinding plates (not the revolution per minute of the entire unit).

14. STOP button which stops the motor.

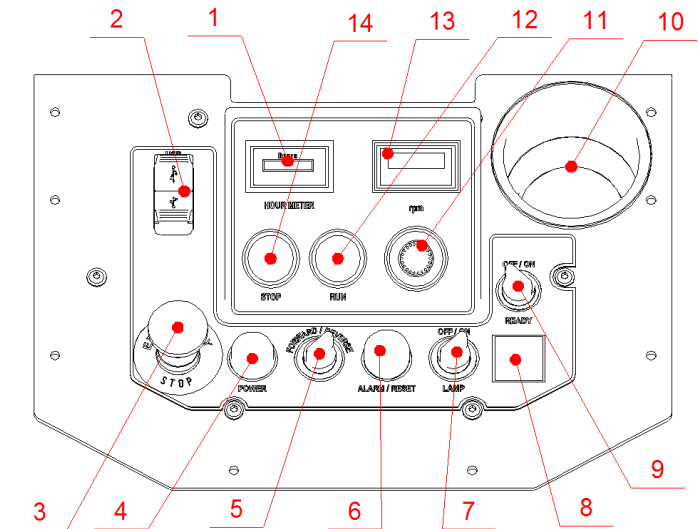

Figure 4.9

4.6 STARTING THE MACHINE

First, follow the directions in the chapter on Safety Devices and Safety Instructions. Next, release the **emergency stop (3)**, turn the **Ready switch (9)** to the ON position to put the machine in standby mode. Check the **potentiometer (11)**, and ensure that it is set to the working speed. If you are working wet, add water to the floor surface. If you are working dry make sure your machine is connected to the vacuum unit. Finally, hold the machine firmly and push the **RUN button (12)**.

4.7 OPERATING THE MACHINE

Guide the machine in straight lines across the floor, slightly overlapping the previously completed surface with each new line. Work at a constant speed, allowing the tools time to work at a speed appropriate for the tools' grit size. Avoid vibrations. Do not stop the machine while tools are still running as they will mark the surface of the floor. When working wet, select the destination of the water feed with the water tap (fig. 4.2) When working dry, check the floor surface periodically for dust accumulation. Check regularly to see if you're vacuum works properly.

4.8 STOPPING THE MACHINE

The stopping of the machine must be done gradually until the motor stops. Do not stop moving the machine before the motor comes to rest, as the tools could damage the surface.

To stop the machine:

1. Push the STOP button (14).

2. Turn the ON/OFF (9) switch in position OFF, this will cut the voltage to the inverter and the green light will turn off.

5. TOOLS AND ACCESSORIES

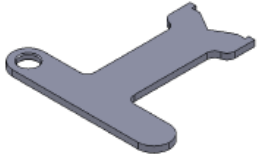

Figure 5.1

TOOL HOLDER KEY

The tool holder key (Fig. 5.1) is used for adjusting, mounting and dismounting of the foam plates. Always use the key for mounting.
Item number is A03.00.00.00

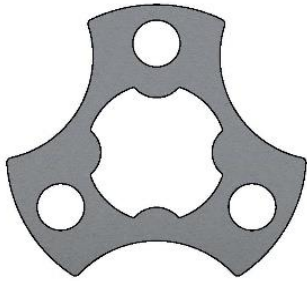

Figure 5.2

SECURITY PLATE FOR QUICKCHANGE PADS

Plate (Fig.5.2) used to ensure the “Quickchange” tools.
Item number is A63.00.01



Figure 5.3

Security plate for RING TOOLS

Plate (Fig.5.3) used to ensure the “Ring” tools.
Item number is A85.00.00

6. POPULAR TOOLS

The heads have clockwise / right rotation. Use the black PCDs and Carbide Scrapers / available reverse /.

RECOMMENDED TOOLS



QuickChange System and Tooling feature extremely fast and convenient tool changes, and a long tool life, providing for great long-term cost savings. The QuickChange pads are produced in four different bonds for super hard, hard, medium and soft concrete, in a variety of grit sizes. They are offered with 1 or 2 buttons or rectangular segments, which allows you to customize the aggressiveness of the cut.

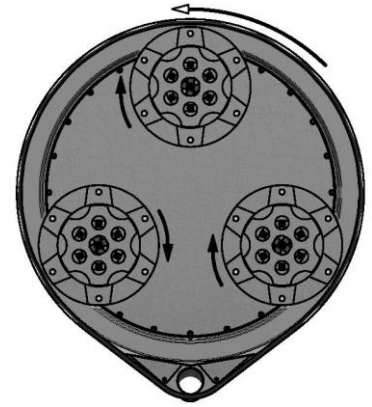

CORSA HYBRID DISCS WITH QUICK CHANGE ATTACHMENT (WET OR DRY) : The new Corsa hybrid discs are designed for scratch removal and transitioning from metal to resin tools, and are similar to Calibra but the ceramic bond has been modified for more efficient use on soft and medium concrete.



NATO® WITH QUICK CHANGE ATTACHMENT

Superabrasive's Nato resin pucks are a great tool choice for soft and hard concrete polishing applications. Among the thickest diamond pads on the market - featuring a thick 12mm layer of resin and diamonds for extra long life. Wide channels and a unique patented design allow for work on a cleaner surface, ensuring a quality polish. Offered in wet and dry bond.



V-HARR® Premium Polishing Pads for 9-inch TOOL HOLDERS

NOW AVAILABLE IN A QUICK CHANGE STYLE - NO FOAM PLATES NEEDED

V-Harr felt diamond pads are one of Superabrasive's most versatile and successful diamond tools for concrete polishing. V-Harr pads are also ideal for polishing terrazzo and hard stone floors. V-Harr polishing pads should be used DRY on concrete! However, they will produce remarkable gloss results on black granite when used wet.



Hybrid and resin tool rings

Exceptional flexibility with a thick layer of flexible foam.

Quick and easy magnetic attachment directly to the grinding heads.

Offered in 9" and 13" – compatible with lavina grinders and trowels.

Use Only Superabrasive's Recommended Tools. For More Tooling Options, Visit www.superabrasive.com

7. MAINTENANCE AND INSPECTION

CLEANING

Keep your machine clean. Cleaning the machine on a regular basis will help detect and solve potential problems before they can cause damage to the machine. Most importantly, check and clean the tool plate connections, power cords, plugs, vacuum hoses, and water tank.

CHECK DAILY

After operating the **LAVINA® LEB/ LAVINA® LEHVB** machine, the operator should conduct a visual inspection of the machine. Any defect should be solved immediately. Pay attention to power cords, plugs, vacuum hoses, loose bolts or screws.

Tool holders: Buffers and elastic element are consumables and must be visually checked on a daily basis and replaced if necessary. Make sure the flanges or discs are securely locked in place. The key lock holders (butterflies) should also be checked.

Check the rubber buffers and make sure the holders are secure. The flange holding the buffers (Fig.7.1-1) has to be firmly secured to the unit. If there is a gap seen here, that means the screws securing the holder are loose. The screws have to be tightened immediately to safely operate the machine. Working with loose screws could cause serious damage to the machine. The tightening force of the screws has to be 22-25N.m (16-18ft-lbf).

It is very important to regularly check the screws that secure the “QuickChange” holder to the safety part (Fig.7.1- 2), so that the holder will not fly away if the buffers get damaged. The

“QuickChange” should also be cleaned.

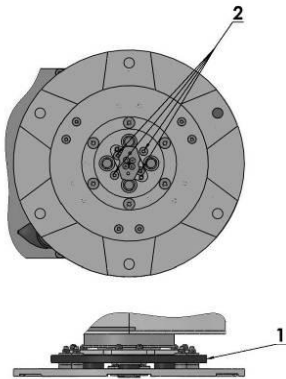

Figure 7.1

CHECK EVERY 200 WORKING HOURS

Every 200 working hours, the operator should inspect all parts of the machine carefully. Most importantly, inspect and clean the tool plate connections, power cord plugs, vacuum hoses and water tank/filter. Check the guard assembly. Ensure the wheels are clean and rotate properly. Inspect the control buttons. If there are defective control parts, they should be replaced immediately. Replace any worn vacuum or water hoses.

Open the service cover on the motor base (Fig 7.2) (Fig 7.3) to check the planetary chain. Lubricate the chain with chain lubricant and correct the sag if needed. (For sagging correction see TROUBLESHOOTING 8.4)

Dismount the tool holders (See TROUBLESHOOTING) and replace any parts (elastic element, buffers, sealer caps, “O” rings) showing any damage.

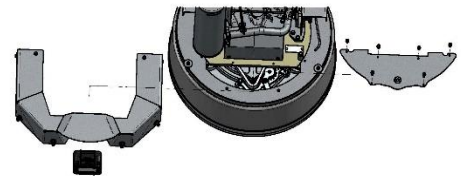

Figure 7.2



Figure 7.3

CHECK EVERY 400 WORKING HOURS

In addition to checks made every 200 working hours, replace sealer and V-rings as described in chapter “TROUBLESHOOTING - DISMOUNTING TOOL HOLDERS TO CHANGING V-RINGS AND FELT-RINGS.

VACUUM

As stated previously, frequently check hoses and other parts for clogging.

WATER LEAKS

Replace any leaking parts immediately as the water could damage your machine.

MECHANICAL PARTS

Parts such as the belts, seal rings, cap rings, spiders and buffers and guard assembly are subject to wear and should be replaced as needed.

8. TROUBLESHOOTING

INDEX OF PROBLEMS AND SOLUTIONS

OPERATION	INTERVAL		
	Daily	Every 200 Hrs.	Every 400 Hrs.
Inspect power cords, plugs and vacuum hoses, loose bolt or screws.	X		
Check the rubber buffers, elastic element and fixing of the holders	X		
Inspect and clean the tool plate connections		X	
Inspect and clean water tank		X	X
Inspect the seal rings and bearings of the grinding units		X	
Check the planetary chain and lubricate		X	X
Replace Felt-Ring and V-rings			X
Check belts and bearings			X

8.1 SEPARATING THE HEAD FROM THE CARRIAGE



Figure 8.1

1. Unscrew the four bolts to remove the panel fig. 8.2-1.
2. Disconnect the flexible hose supplying water under the cover of the machine fig. 8.2-2.
3. Disconnect the cable of lamp and remove the lamp fig. 8.2-3.
4. Unscrew the four bolts to remove the cover fig. 8.2-4.
5. Disconnect the engine cable from the power box fig. 8.2-5.
6. Release the clamp and remove the suction hose from the head fig. 8.2-6.
7. Make sure everything is disconnected fig. 8.2-7
8. **For separating the carriage from the head you need to be two people** – one to hold the carriage while the other removes the pins fig 8.2-8. After the pins are removed the person which is holding the carriage should carefully place it on the ground without harming it fig. 8.1.

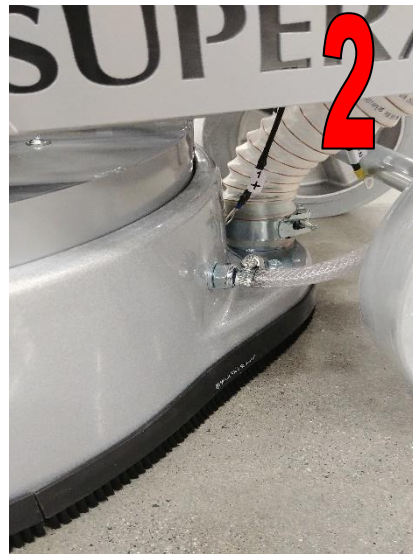

Figure 8.2

8.2 DISMOUNTING/MOUNTING THE GUARD

You can dismount and mount the safe guard without separating the carriage from the main head. Put the machine in position to change the tools. Unscrew the four bolts M5 from the metal cover preventing the safe guard to fall. Dismount one of the three holders. Dismount the safe guard.



Figure 8.3



Figure 8.4

8.3 REPLACING POWER CORD AND PLUGS

When replacing the power cord or plugs, always use cords and plugs with the same specifications as the original ones. Do not use lower quality or different types of cords or plugs.

In addition, consider the distance between the appliance and the electrical source. The greater the distance, the greater the resistance and the less current that will be available at the other end. This will cause a voltage drop and the inverter will switch into alarm mode. This will also happen if several machines are working on the same line or the generator is not rated for the power needed. In general, our standard power cable can be doubled in length; longer lengths require replacing all the cables with cables of a larger gauge rate to account for the length and amperage.

8.4 DISMOUNTING AND MOUNTING TOOL HOLDER TO CHANGING V-RINGS AND FELT-RINGS



Figure 8.4.1



Figure 8.4.2



Figure 8.4.3



Figure 8.4.4



Figure 8.4.5



Figure 8.4.6

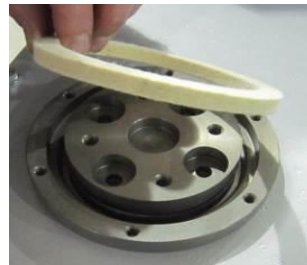

Figure 8.4.7

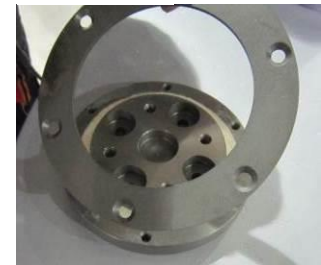

Figure 8.4.8

To check or replace the buffers and the elastic elements, the tool holders have to be dismounted.

You will need a 13mm deep metric socket with an outside diameter of no more than 3/4in to unscrew the four bolts (Fig.8.4.1) and remove the holder (Fig.8.4.2). When the tool holder is dismounted, you can change the sealers (V-Ring and Felt-Ring).

By loosening four Hex cap flange bolts (Fig.8.4.3) the adaptor comes loose. Unscrew the six screws of the cap (Fig.8.4.4) holding the felt-ring. Take out the Felt-Ring, adaptor and V-Ring.

Mount the V-Ring with the smallest lip of the V to the inside (Fig.8.4.5) - simply push the V-Ring so the top is on the same level as the pulley top (Fig.8.2.6). Then take the adaptor and push the V-Ring down with the adaptor (Fig.8.4.7). The lowest lip of the V-Ring should only barely touch its gliding surface. Mount the adaptor and the Felt-Ring on top (Fig.8.4.7). Close the sealers with the cap (Fig.8.4.8) and screw the bolts. Always use the original bolts. Do not push the V-ring down with fingers.

8.5 DISASSEMBLING AND MOUNTING TOOL HOLDER TO CHANGE BUFFERS AND ELASTIC ELEMENT

When the TOOL HOLDER is disassembled you can change defective parts – elastic element, buffers, etc.

Lift the locking pin (Fig.8.5.1) to dismount the retaining

washer (Fig.8.5.2). Take out the screws on the buffers and the nuts of the elastic element (Fig.8.5.3;Fig.8.5.4). Remove the elastic element from the QC plate (Fig.8.5.5). While the holder is dismantled (Fig.8.5.6;Fig.8.5.7), clean the parts and replace any defective ones with new ones. Assemble the holder with new buffers, new screws, and new elastic element. Replace the retaining washer (Fig.8.5.8) and push the locking pin (Fig.8.5.9). This will prevent the washer from falling while mounting the holder on the machine.



Figure 8.5.1



Figure 8.5.2

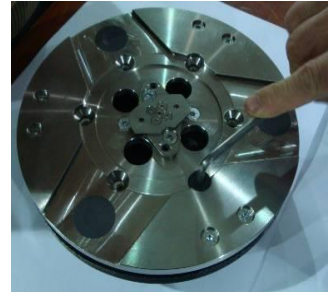

Figure 8.5.3

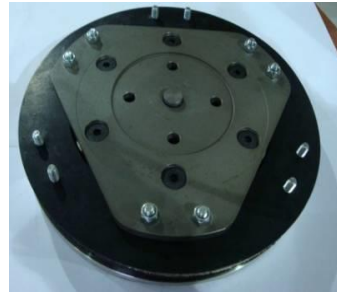

Figure 8.5.4



Figure 8.5.5



Figure 8.5.6

Make sure the four bolts holding the adaptor (Fig.8.5.12) are reliably tighten. Mount the holder on the machine using the same socket as mentioned in 8.2 (Fig.8.5.10;Fig.8.5.11). The retaining washer fits into the central hole C of adaptor and the four bolts into the thread holes T (Fig.8.5.12). The holder is centered on the outside diameter of the adaptor. Ensure the holder is properly connected to the plate of the adaptor and then tight evenly the four bolts. Tightening force of the bolts has to be 22...25N.m(16...18 ft/lbs). Mounting the holder without retaining washer (Fig.8.5.2) is **INADMISSIBLE** because the security system preventing the separation of part of the holder in case of broken buffers and elastic element will not function! You can change the butterfly of the holder without dismantling the holder of the machine.



Figure 8.5.7



Figure 8.5.8

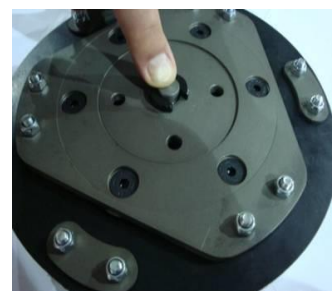

Figure 8.5.9

Mounting the holder without retaining washer (Fig.8.5.2) is **INADMISSIBLE** because the security system preventing the separation of part of the holder in case of broken buffers and elastic element will not function! You can change the butterfly of the holder without dismantling the holder of the machine.



Figure 8.5.10



Figure 8.5.11

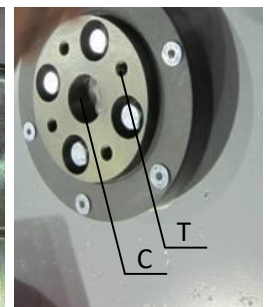

Figure 8.5.12

You can change the butterfly of the holder without dismantling the holder of the machine. Fig.8.5.13 is a 3-D section view of the holder, showing its parts. The numbering is the same as in Spare parts.

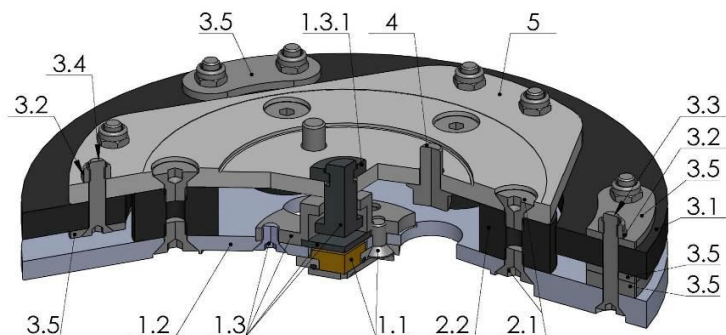

Figure 8.5.13

8.6 CORRECTING DEFLECTION OF THE USED PLANETARY CHAIN

Unscrew the bolts and take out the cover (Fig.8.6.1). Lift the machine in position to change the tools. Turn manually the holders in order to turn the main head, stop when you see through the window the chain tensioner (Fig.8.6.2).

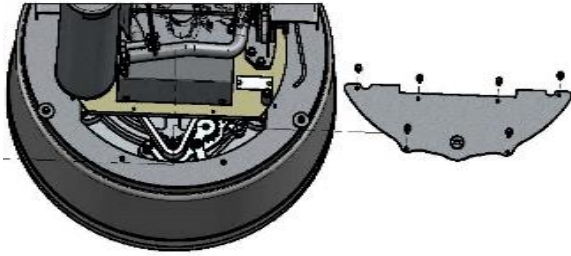

Figure 8.6.1



Figure 8.6.2

Loosen a quarter to 1/2 rev the two bolts of the chain tensioner (Fig.8.6.3) the tensioner should turn with minimum clearance, without inclination, then unscrew the inner nut. To tension the chain screw the outer nut (Fig.8.6.4).

The tensioner of the planetary chain should allow chain sagging 3...5mm/1/8...3/16 in/ controlled in span X (Fig.8.6.5). When ready screw the two nuts (Fig.8.6.4) and the screw (Fig.8.6.3).

ATTENTION: NEVER "OVER" TENSION THE CHAIN, THE CHAIN WILL BE DAMAGED



Figure 8.6.3

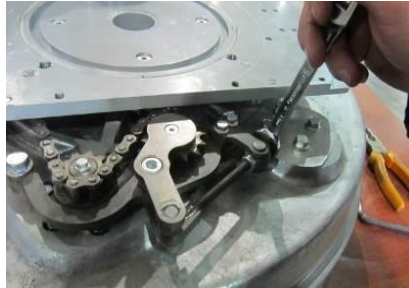

Figure 8.6.4



Figure 8.6.5

MOUNTING NEW PLANETARY CHAIN

The planetary chain is replaced with new one when the step/drive of the chain tensioner is finished or there is a break in the integrity of the chain. Unscrew the bolts (Fig.8.6.1) and take out the cover. Lift the machine in position to change the tools. Turn manually the holders in order to turn the main head, stop when you see through the window the chain tensioner (Fig.8.6.2). Separate the carriage from main head, point 8.4, pull out motor plug, water tubes and vacuum tubes. Take off handle (without water tubes). Release the pin sets which attach the head to the carriage. Take off the service window (Fig. 8.6.1) so you can dismount the top cover

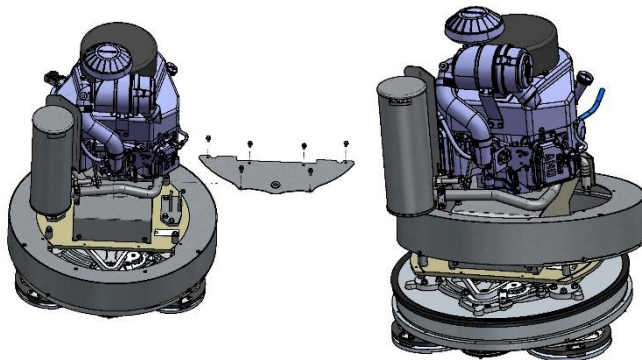

Figure 8.6.1

Loosen the two nuts (Fig.8.6.4) and unscrew the two screws of the tensioner (Fig.8.6.8)(Fig.8.6.9)(Fig.8.6.10). Take the chain tensioner (Fig.8.6.11). Pull out the split pin (Fig.8.6.12) and the chain link pin (Fig.8.9.8) (Fig.8.6.13). Take the chain, and put on the same way the new chain, get in the chain link pin and the split pin (Fig.8.6.13) (Fig.8.6.12) (Fig.8.6.11).



Figure 8.6.8



Figure 8.6.9



Figure 8.6.10



Figure 8.6.11



Figure 8.6.12



Figure 8.6.13

Mount the chain tensioner (Fig.8.6.10). Tighten the two screws (Fig.8.6.8)(Fig.8.6.9). Loosen the bolt of the chain tensioner a quarter to a half revolution (Fig.8.6.9). The tensioner should turn with minimum clearance, without inclination. Then unscrew the inner nut. To tension the chain, rotate the outer nut (Fig.8.6.4) . The tension of the planetary chain should allow chain sagging of 3...5mm (1/8...3/16 in) measured in span X (Fig.8.6.5).

When properly tensioned, retighten the two nuts (Fig.8.6.4) and the screw(Fig.8.6.9).

ATTENTION: NEVER "OVER" TENSION THE CHAIN, THE CHAIN WILL BE DAMAGED

8.7 REPLACING THE PLANETARY DRIVING CHAIN WHEEL AND PLANETARY TENSIONER

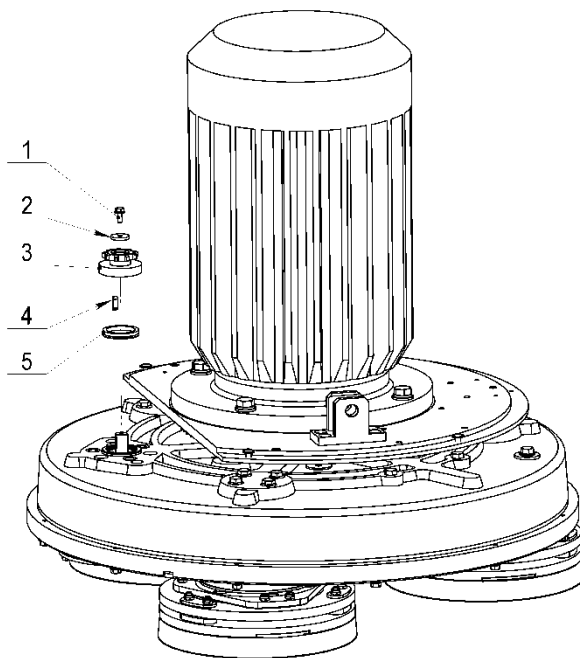

Figure 8.7.1

Check and repeat the instructions in 8.5 MOUNTING NEW PLANETARY CHAIN.

Unscrew bolt (1) and remove the chain pulley (3) with the sealer (5). Change the sealer, and mount it to the chain pulley (3). Apply lithium grease on the shaft and mount back the wheel and the front washer (2) as shown on (Fig.8.7.1). Screw the bolt using the "blue" thread locking adhesive. Tightening force on the bolts should be 9...11N.m(6.6...8 ft-lbf).

8.8 TENSIONING AND REPLACING THE BELTS



Figure 8.8.1

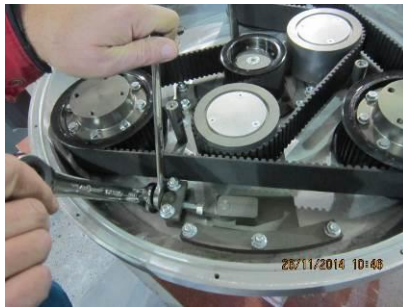

Figure 8.8.2



Figure 8.8.3

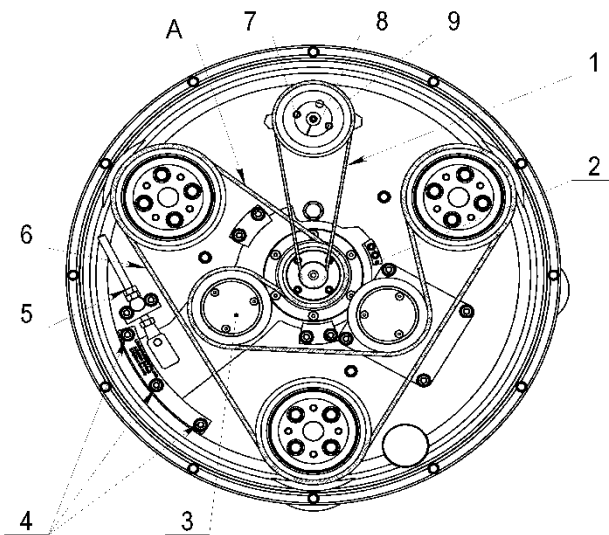

Figure 8.8.4

tensioners with minimal force.

Using nuts (5), tighten the belt, double checking the position/orientation of the belt and the gearing in each pulley.

Rotate the gear while tensioning to allow regular distribution of tension along the belt.

Measure the tension using a Frequency Tension Tester (Optibelt 3 TT) (Fig. 8.8.3). Tension in span "A" of the belt should be 120-130Hz. It is possible to use the pre-installed support (Fig. 8.8.4-2)(Fig. 8.8.5) as a reference to stop the tensioner at the desired belt tension, provided that the supports have not been moved from their factory position.



ATTENTION: NEVER "OVER" TENSION THE BELT, THE BELT WILL BE DESTROYED AND IT WILL NEVER RECOVER ITS ORIGINAL TENSION

To remove the planetary belt (Fig.8.8.4-1), unscrew the screw of the front washer (Fig.8.8.6) and the two screws of the conical sleeve (Fig.8.8.7). Screw one of the removed screws into the free thread(Fig.8.8.8) to push the washer down (Fig.8.8.9); take off the conical sleeve and the belt (Fig.8.8.10).



Figure 8.8.6



Figure 8.8.7

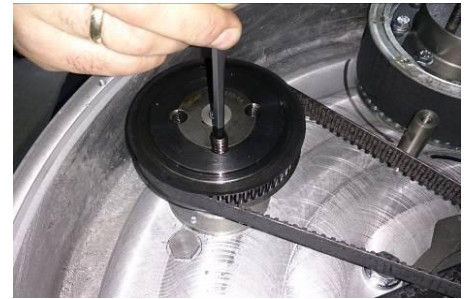

Figure 8.8.8



Figure 8.8.9



Figure 8.8.10

The reassembly is the same process in reverse. It is important to match the threads of the conical sleeve and the belt washer (Fig.8.8.11). Put the front washer (Fig.8.8.12), on the screw - using "blue" thread locking adhesive. Tightening force of the bolts has to be 4,5...6N.m(3,3...4,4 ft/lbs). Carefully replace the two binder screws while leaving the central thread open. (Fig.8.8.12)(Fig.8.8.13). Insert the screws by alternating at 1.5 revolution each until the conical sleeve pulls up the belt pulley. The conical sleeve must be aligned in height with the belt washer (Fig.8.8.14).



Figure 8.8.11



Figure 8.8.12



Figure 8.8.13



Figure 8.8.14

Dismounting the planetary belt is possible without removing of the Bottom cover assembly by unscrewing the eight



Figure 8.8.15



Figure 8.8.16



Figure 8.8.17

bolts and removing the service window cover and the sealing (Fig.8.8.15)(Fig.8.8.16) to access the planetary belt (see 8.8.17)

8.9 REPLACING THE DRIVEN PLANETARY GEAR (SPROCKET)

Remove the planetary chain and tensioner (see 8.6 - MOUNTING NEW PLANETARY CHAIN).

Dismount the tool holders, sealers, and bottom cover (TENSIONING AND REPLACING THE BELTS). Unscrew the cap to access the fastening bolts of the driven gear (Fig.8.9.1)(Fig.8.9.2). Rotate the main head such that you see a fastening bolt of the gear (Fig.8.9.3) through the hole.

You will need a 10mm magnetic deep metric socket with an outside diameter of no more than 11/16 in to unscrew the six bolts (Fig.8.9.3)(Fig.8.9.4) (Fig.8.9.5). Once these are removed, remove the two halves of the gear. The gear is composed of two symmetrical halves(Fig.8.9.6). Mount them in reverse order.

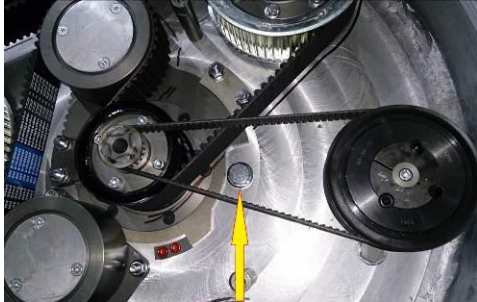

Figure 8.9.1



Figure 8.9.2

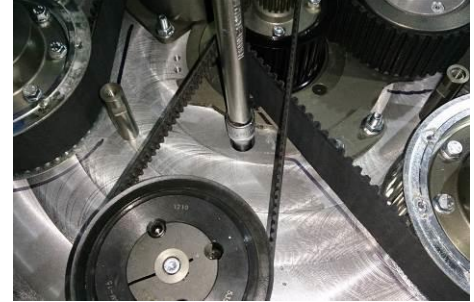

Figure 8.9.3



Figure 8.9.4

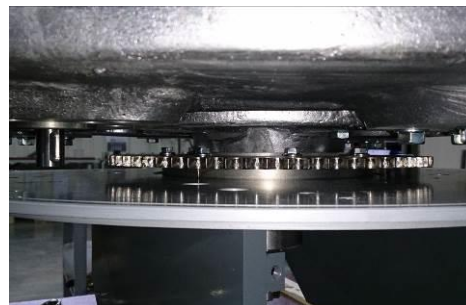

Figure 8.9.5



Figure 8.9.6

8.10 REPLACING THE PULLEY UNITS

Dismount guard, top cover, maintenance window chain tensioner, driven chain wheel, bottom cover and belts as previous described.



Figure 8.10.1



Figure 8.10.2



Figure 8.10.3

Unscrew the four bolts of each pulley between the base plate and the motor base disc (Fig.8.10.1)(Fig.8.10.2) and dismount the pulley (Fig.8.10.3).

A seal (Fig.8.10.4) should be placed on top of the pulley before mounting.



Figure 8.10.4



Figure 8.11.1



Figure 8.11.2



Figure 8.11.3

Unscrew the six bolts (Fig.8.11.1)(Fig.8.11.2) and press down the planetary unit.
When mounting back secure with sealant (fig.8.11.3).

8.12 MOTOR CONNECTION

In case the motor is being replaced, please follow the cable connections in the figures below (Fig.8.12.1), (Fig.8.12.2).

Lavina® 25LEB

The motor is connected in "Delta"
(triangle) 230 Volt,
reminder for the wire connection of
the motor.

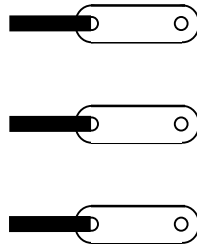

Fig.8.12.1

Lavina® 25LEHVB

The motor is connected in "Star"
380 Volt, reminder for the wire connection
of the motor.

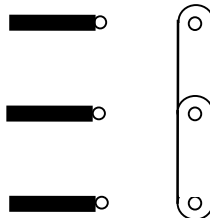

Fig.8.12.2

8.13 FAULT DIAGNOSIS INVERTER YASKAWA V1000

Pages are referring to Yaskawa Electric SIEP C710606 18A

YASKAWA AC Drive – V1000 Technical Manual

◆ Types of Alarms, Faults, and Errors

Check the LED operator for information about possible faults if the drive or motor fails to operate. *Refer to Using the Digital LED Operator on page 70.*

If problems occur that are not covered in this manual, contact the nearest Yaskawa representative with the following information:

- Drive model
- Software version
- Date of purchase
- Description of the problem

Table 6.4 contains descriptions of the various types of alarms, faults, and errors that may occur while operating the drive. Contact Yaskawa in the event of drive failure.

Table 6.4 Types of Alarms, Faults, and Errors

Type	Drive Responses to Alarms, Faults, and Errors
Faults	<p>When the drive detects a fault:</p> <ul style="list-style-type: none"> • The digital operator displays text that indicates the specific fault and the ALM indicator LED remains lit until the fault is reset. • The fault interrupts drive output and the motor coasts to a stop. • Depending on the setting, the drive and motor may stop via different methods than listed. • If a digital output is programmed for fault output (H2-□□ = E), it will close if a fault occurs. • When the drive detects a fault, it will remain inoperable until that fault has been reset. <i>Refer to Fault Reset Methods on page 264.</i>
Minor Faults and Alarms	<p>When the drive detects an alarm or a minor fault:</p> <ul style="list-style-type: none"> • The digital operator displays text that indicates the specific alarm or minor fault and the ALM indicator LED flashes. • The motor does not stop. • One of the multi-function contact outputs closes if set to be tripped by a minor fault (H2-□□ = 10), but not by an alarm. • The digital operator displays text indicating a specific alarm and ALM indicator LED flashes. • Remove the cause of an alarm or minor fault to automatically reset.
Operation Errors	<p>When parameter settings conflict with one another or do not match hardware settings (such as with an option card), it results in an operation error.</p> <p>When the drive detects an operation error:</p> <ul style="list-style-type: none"> • The digital operator displays text that indicates the specific error. • Multi-function contact outputs do not operate. • When the drive detects an operation error, it will not operate the motor until the error has been reset. Correct the settings that caused the operation error to reset.
Tuning Errors	<p>Tuning errors occur while performing Auto-Tuning.</p> <p>When the drive detects a tuning error:</p> <ul style="list-style-type: none"> • The digital operator displays text indicating the specific error. • Multi-function contact outputs do not operate. • Motor coasts to stop. • Remove the cause of the error and repeat the Auto-Tuning process.

◆ Alarm and Error Displays

■ Faults

When the drive detects a fault, the ALM indicator LEDs remain lit without flashing. If the LEDs flash, the drive has detected a minor fault or alarm. *Refer to Minor Faults and Alarms on page 240* for more information. An overvoltage situation trips both faults and minor faults, therefore it is important to note whether the LEDs remain lit or if the LEDs flash.

LED Operator Display	Name	Page	LED Operator Display	Name	Page
bUS	bUS Option Communication Error	242	[PF08]	CPF08 EEPROM Serial Communications Fault	243
[E]	CE MEMOBUS/Modbus Communication Error	242	[PF11]	CPF11 RAM Fault	243
[F]	CF Control Fault	242	[PF12]	CPF12 FLASH Memory Fault	243
[CoF]	CoF Current Offset Fault	242	[PF13]	CPF13 Watchdog Circuit Exception	243
[PF02]	CPF02 A/D Conversion Error	242	[PF14]	CPF14 Control Circuit Fault	243
[PF03]	CPF03 PWM Data Fault	243	[PF16]	CPF16 Clock Fault	243
[PF06]	CPF06 Drive specification mismatch during Terminal Board or Control Board replacement	243	[PF17]	CPF17 Timing Fault	243
[PF07]	CPF07 Terminal Board Communication Fault	243	[PF18]	CPF18 Control Circuit Fault	243
			[PF19]	CPF19 Control Circuit Fault	244

LED Operator Display		Name	Page	LED Operator Display		Name	Page
CPF20 or CPF21	CPF20or CPF21	RAM Fault	244	GF	GF	Ground Fault	245
		FLASH Memory Fault	244	LF	LF	Output Phase Loss	245
		Watchdog Circuit Exception	244	LF2	LF2	Output Open Phase	246
		Clock Fault	244	oC	oC	Overcurrent	246
oH3	oH3	Motor Overheat 1 (PTC input)	247	oFA00	oFA00	Option Card Fault (port A)	246
oH4	oH4	Motor Overheat 2 (PTC input)	248	oH	oH	Heatsink Overheat	247
oL1	oL1	Motor Overload	248	oH1	oH1	Heatsink Overheat	247
oL2	oL2	Drive Overload	248	PGo	PGo	PG Disconnect (for Simple V/f with PG)	250
oL3	oL3	Overtorque Detection 1	249	rH	rH	Dynamic Braking Resistor	251
oL4	oL4	Overtorque Detection 2	249	rr	rr	Dynamic Braking Transistor	251
oL5	oL5	Mechanical Weakening Detection 1	249	SEr	SEr	Too Many Speed Search Restarts	251
oL7	oL7	High Slip Braking oL	249	SFO	STO	Pull-Out Detection	251
oPr	oPr	Operator Connection Fault	249	UL3	UL3	Undertorque Detection 1	251
CPF22	CPF22	A/D Conversion Error	244	UL4	UL4	Undertorque Detection 2	251
CPF23	CPF23	PWM Feedback Data Fault	244	UL5	UL5	Mechanical Weakening Detection 2	251
CPF24	CPF24	Drive Capacity Signal Fault	244	Uv1	Uv1	Undervoltage	252
dEv	dEv	Excessive Speed Deviation (for Simple V/f with PG)	244	Uv2	Uv2	Control Power Supply Undervoltage	252
EF0	EF0	Option Card External Fault	244	Uv3	Uv3	Soft Charge Circuit Fault	252
EF1 to EF7	EF1 to EF7	External Fault (input terminal S1 to S7)	244	oS	oS	Overspeed (for Simple V/f with PG)	249
FbH	FbH	Excessive PID Feedback	245	ov	ov	Overvoltage	249
FbL	FbL	PID Feedback Loss	245	PF	PF	Input Phase Loss	250

Note: If faults CPF11 through CPF19 occur, the LED operator will display CPF00 or CPF11.

Minor Faults and Alarms

When a minor fault or alarm occurs, the ALM LED flashes and the text display shows an alarm code. A fault has occurred if the text remains lit and does not flash. Refer to Alarm Detection on page 253. An overvoltage situation, for example, can trigger both faults and minor faults. It is therefore important to note whether the LEDs remain lit or if the LEDs flash.

Table 6.5 Minor Fault and Alarm Displays

LED Operator Display		Name	Minor Fault Output (H2-□□ = 10)	Page
bb	bb	Drive Baseblock	No output	253
bUS	bUS	Option Card Communications Error	YES	253
CALL	CALL	Serial Communication Transmission Error	YES	253
CE	CE	MEMOBUS/Modbus Communication Error	YES	253
CrSt	CrSt	Can Not Reset	YES	253
dEv	dEv	Excessive Speed Deviation (for Simple V/f with PG)	YES	254
dnE	dnE	Drive Disabled	YES	254
EF	EF	Run Command Input Error	YES	254
EF0	EF0	Option Card External Fault	YES	254
EF1 to EF7	EF1 to EF7	External Fault (input terminal S1 to S7)	YES	255
FbH	FbH	Excessive PID Feedback	YES	255
FbL	FbL	PID Feedback Loss	YES	255
Hbb	Hbb	Safe Disable Signal Input	YES	255
HbbF	HbbF	Safe Disable Signal Input	YES	255
SE	SE	MEMOBUS/Modbus Test Mode Fault	YES	—
oL5	oL5	Mechanical Weakening Detection 1	YES	249
UL5	UL5	Mechanical Weakening Detection 2	YES	251
dWAL	dWAL	DriveWorksEZ Alarm	YES	244
HCA	HCA	Current Alarm	YES	256
oH	oH	Heatsink Overheat	YES	256
oH2	oH2	Drive Overheat	YES	256
oH3	oH3	Motor Overheat	YES	256
oL3	oL3	Overtorque 1	YES	256
oL4	oL4	Overtorque 2	YES	257
oS	oS	Overspeed (for Simple V/f with PG)	YES	257

LED Operator Display		Name	Minor Fault Output (H2-□□ = 10)	Page
ov	ov	Overvoltage	YES	257
PASS	PASS	MEMOBUS/Modbus Test Mode Complete	No output	257
PGo	PGo	PG Disconnect (for Simple V/f with PG)	YES	257
rUn	rUn	During Run 2, Motor Switch Command Input	YES	258
rUnC	rUnC	Run Command Reset	YES	258
UL3	UL3	Undertorque 1	YES	258
UL4	UL4	Undertorque 2	YES	258
Uv	Uv	Undervoltage	YES	258

■ Operation Errors

Table 6.6 Operation Error Displays

LED Operator Display		Name	Page	LED Operator Display		Name	Page
oPE01	oPE01	Drive Unit Setting Error	259	oPE08	oPE08	Parameter Selection Error	260
oPE02	oPE02	Parameter Setting Range Error	259	oPE09	oPE09	PID Control Selection Error	260
oPE03	oPE03	Multi-Function Input Setting Error	259	oPE10	oPE10	V/f Data Setting Error	261
oPE04	oPE04	Terminal Board Mismatch Error	260	oPE11	oPE11	Carrier Frequency Setting Error	261
oPE05	oPE05	Run Command Selection Error	260	oPE13	oPE13	Pulse Train Monitor Selection Error	261
oPE07	oPE07	Multi-Function Analog Input Selection Error	260				

9. DISPOSAL

If your machine after time is not usable or needs to be replaced, send the machine back to Superabrasive or a local distributor, where a professional disposal complying with the environment laws and directives is guaranteed.

10. MANUFACTURER'S CONTACTS

If you need to contact Superabrasive Inc. with technical support questions, below is the contact information. Address: 9411 Jackson Trail Road, Hoschton GA 30548, USA

Email: info@superabrasive.us
 Tel.: 706 658 1122
 Fax: 706 658 0357
 Website: www.superabrasive.com

11. SPARE PARTS

ASSEMBLY AND PARTS SPECIFICATIONS

11.1.GENERAL PARTS

11.1.1 LAVINA®25LEB General parts			
No.	Item No.	Description	Pcs.
1	L25LEB20.00.00	Carriage	1
1*	L25LEB20.00.00-1	Carriage	1
2	L25LEB10.00.00	Main Head	1
2*	L25LEB10.00.00-1	Main Head	1
3	L25LEB01.00.00	Bumper	1
4	L25SPS-07.03.00.00	Pin Assembly	2
5	A50.00.00.00	LED light with magnetic base	1
6	L20E20.00.03	Front cover	1
7	30301230251	Screw M5x16ISO7380F/10.9/	4
8	L25LE02.00.00-K	Lever mount	1

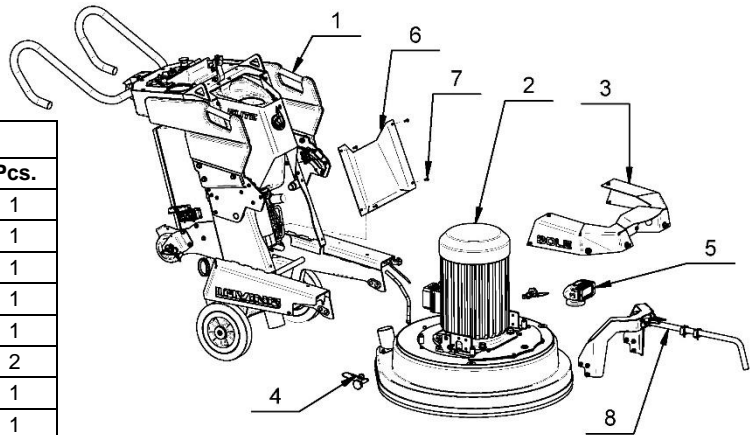

Figure 11.1.1

*The changes are for machines from Serial No 2206L25LEB1001

11.1.2 LAVINA®25LEHVB General parts			
No.	Item No.	Description	Pcs.
1	L25LEHVB20.00.00	Carriage	1
1*	L25LEHVB20.00.00-1	Carriage	1
2	L25LEUB10.00.00	Main Head	1
2*	L25LEUB10.00.00-1	Main Head	1
3	L25LEHVB01.00.00	Bumper	1
4	L25SPS-07.03.00.00	Pin Assembly	2
5	A50.00.00.00	LED light with magnetic base	1
6	L20E20.00.03	Front cover	1
7	30301230251	Screw M5x16ISO7380F/10.9/	4
8	L25LE02.00.00-K	Lever mount	1

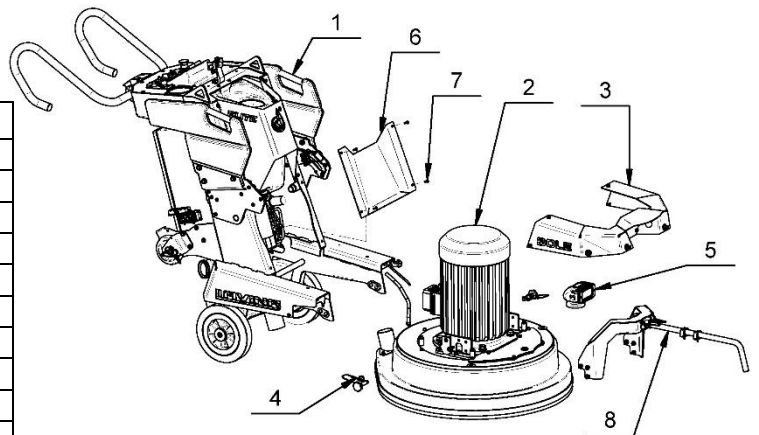

Figure 11.1.2

*The changes are for machines after Serial No

11.2 BUMPER

11.2 LAVINA® 25LEB,25LEHVB Bumper			
No.	Item No.	Description	Pcs.
1	L25LEB01.00.01 -K	Bumper right	1
1*	L25LEHVB01.00.01-K	Bumper right	1
1.1	L25LEB01.00.01	Bumper right part	1
1.1*	L25LEHVB01.00.01	Bumper right part	1
1.2	30311000779	Rubber sleeve	1
2	30301240103	Nut M6DIN985	6
3	L20GX-01.00.03	Bumper middle part	1
4	L25GEB01.00.02	Bumper left part	1
5	30301210048	Bolt M6X12DIN6921	6
6	30301210051	Bolt M6X16DIN6921	4

* For Lavina®25LEHVB

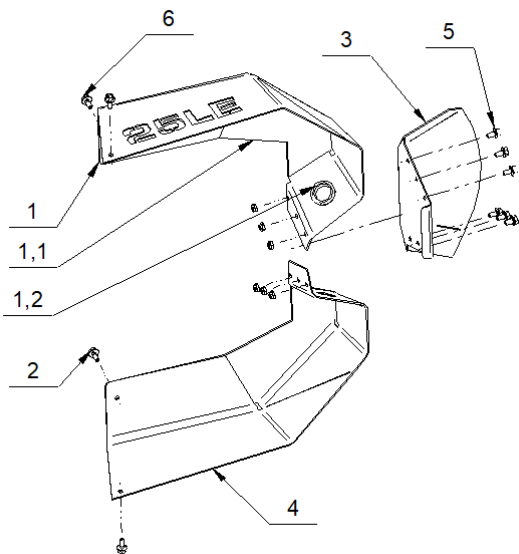
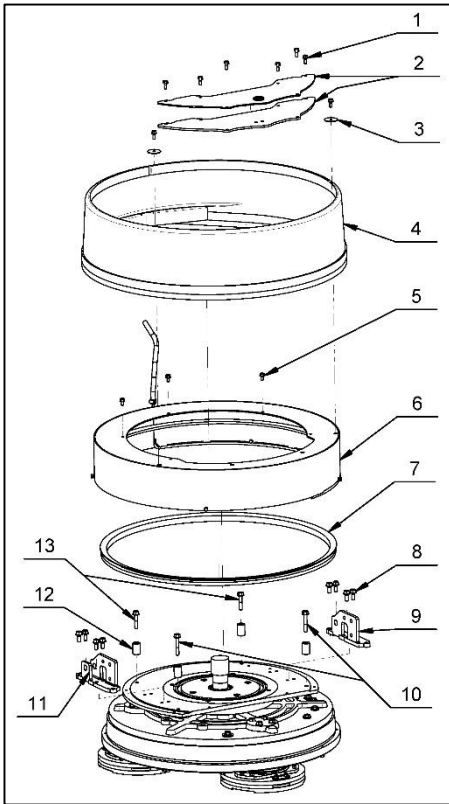

Figure 11.2



11.3 LAVINA® 25LEB,25LEHVB Top Cover 1 parts			
No.	Item No.	Description	Pcs.
1	30301210051	Bolt M6X16DIN6921	8
2	L25LE19.20.00-3	Inspection Cover	1
3	30301221022	Washer D35X1.4	2
4	L25GEB10.70.00	Gard Assembly	1
5	30301210048	Bolt M6X12DIN6921	3
6	L25GEB19.00.00	Top Cover Assembly	1
7	30302000049	V-Ring Type A	1
8	30301210031	Bolt M8X20DIN6921	8
9	L25LE02.20.00	Left Fork	1
10	30301210144	Bolt M8X50DIN6921	2
11	L25LE02.30.00	Right Fork	1
12	L20GX-15.00.29	Bushing	4
13	30301210092	Bolt M8X40DIN6921	2

11.4 GUARD ASSEMBLY

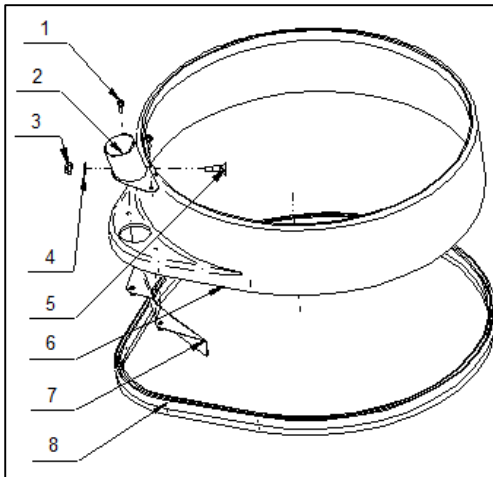

Figure 11.4

11.4 LAVINA®25LEB,25LEHVB Guard Assembly			
Item No. L25GEB10.70.00			
No.	Item No.	Description	Pcs.
1	30301210117	Bolt M6x20DIN6921	2
2	L30E10.71.00	Vacuum Port	1
3	30301240111	Nut M12DIN985	1
4	30301221006	Washer M12DIN125	1
5	L25GEB10.70.02	Nozzle L25GEB	1
6	L25GE-05.00.01	Guard	1
7	L25E10.71.00	Bottom Vacuum Port	1
8	FBL1350-2280	Brush	1

11.5 TOP COVER ASSEMBLY

11.5 LAVINA®25LEB,25LEHVB TOP COVER Assembly			
Item No. L25GEB19.00.00			
No.	Item No.	Description	Pcs.
1	L25GEB19.10.00-K	Top Cover	1
2	30301220001	Spring Washer M5DIN127	4
3	30301210007	Bolt M5X10DIN933	4
4	30301221022	Washer D35x1.4	2
5	30301210051	Bolt M6X16DIN6921	2

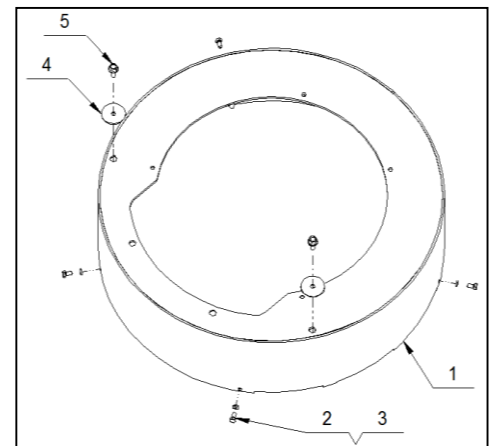

Figure 11.5

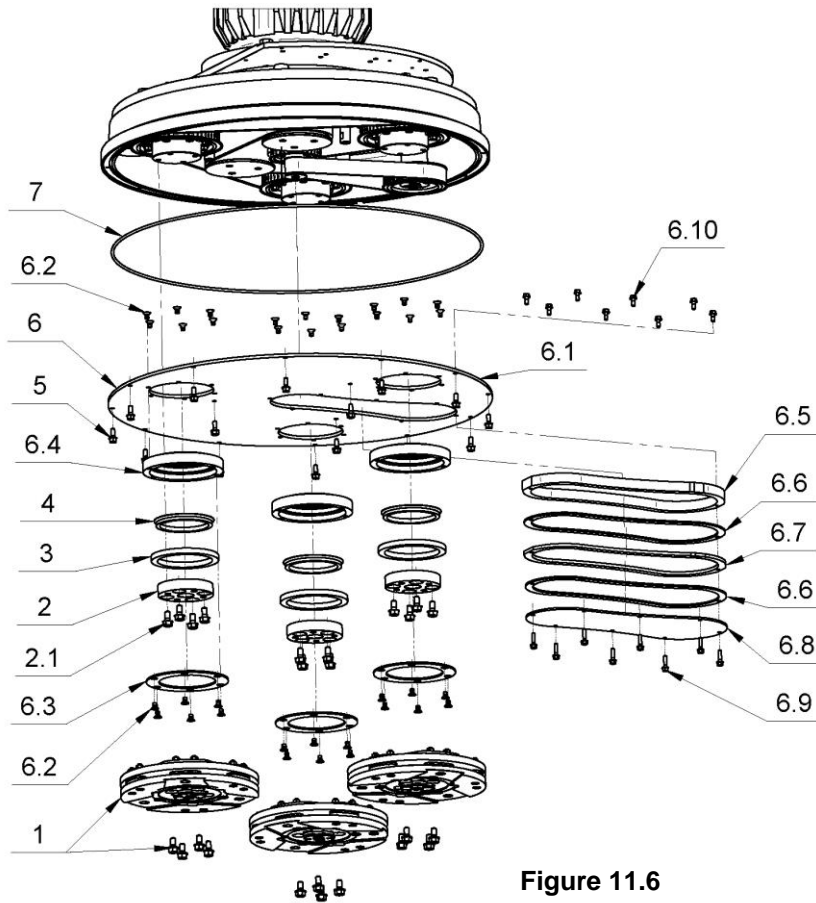

Figure 11.6

11.6. LAVINA® 25LEB,25LEHVB Bottom Cover 1 Parts			
No.	Item No.	Description	Pcs.
1	A63.00.00	Tool Holder A63	3
2	A42.03.00	Adaptor	3
	2.1 30301210072	Bolt M8x16DIN6921	4
3	30309000000	Felt Ring	3
4	30302000005	V-Ring Type A	3
5	30301210051	Bolt M6x16DIN6921	15
6	L25X-14.00.00-R2	Bottom Cover Assembly	1
	6.1 L25X-14.00.01	Bottom Cover	1
	6.2 30301230017	Screw M6X10DIN7991/10.9/	36
	6.3 L25LS-14.00.03	Outer Cover	3
	6.4 L25LS-14.00.02	Flange	3
	6.5 L25X-14.00.05	Flange	1
	6.6 L25X-14.00.04	Sealer Inspection Cover	2
	6.7 L25X-14.00.06	Pad 2	1
	6.8 L25X-14.10.01-R2	Inspection Cover	1
	6.9 30301210105	Bolt M5X20DIN6921	8
6.10 30301210030	Bolt M5X12DIN6921	8	
7	D4X2X1900	Seal	1

11.7 PLANETARY DRIVE PARTS

11.7. LAVINA® 25LEB,25LEHVB Planetary Drive Parts				
No.	Item No.	Description	Pcs.	
1	30301230098	Screw M6X16DIN912	4	
2	L25X-03.00.00-R2	Pulley	1	
3	L25LE10.00.55-K	Front Washer Assembly	1	
	3.1	30301210019	Bolt M16X35DIN933	1
	3.2	30301221052	Washer DIN432-17	1
	3.3	L25LE10.00.55	Front Washer	1
4	L25LX-10.10.00	Central Pulley	1	
5	L25LX-10.00.29	Distance Ring	1	
6	30301250002	Retaining Ring B65DIN471	1	
7	30301230002	Screw M6x16DIN7991	6	
8	L25X-10.00.17	Cap	1	
9	30303000012	Roller Assembly	2	
10	L25SPS-00.00.00.34	Distance Ring	1	
11	30301250009	Retaining Ring	1	
12	L25X-11.00.00	Pulley Unit Assembly	3	
	12.1	30301210032	Bolt M8X35DIN6921	4
13	30302000008	V-Ring Type A	1	
14	08BH-1-78	Chain	1	
15	30301210051	Bolt M6X16DIN6921	8	
16	L25X-15.00.12	Chain Pulley	2	
17	L25X-15.00.03	Flange	1	
18	L25LE15.20.00	Base plate	1	
19	30301230056	Screw M8X16DIN7991	4	
20	30301210066	Bolt M16X30DIN933	4	
21	30301220006	Spring Washer M16DIN127B	4	
22	30301221008	Washer M16DIN125A	4	
23	S255	Electro Motor	1	
	23.1	30301260072	Key DIN6885A12X8X36	1
24	D4X2X850	Seal	1	
25	L25X-17.00.00	Chain Tensioner	1	
	25.1	30301210021	Bolt M10X35DIN6921	1
	25.2	30301230007	Screw M10x35DIN912	1

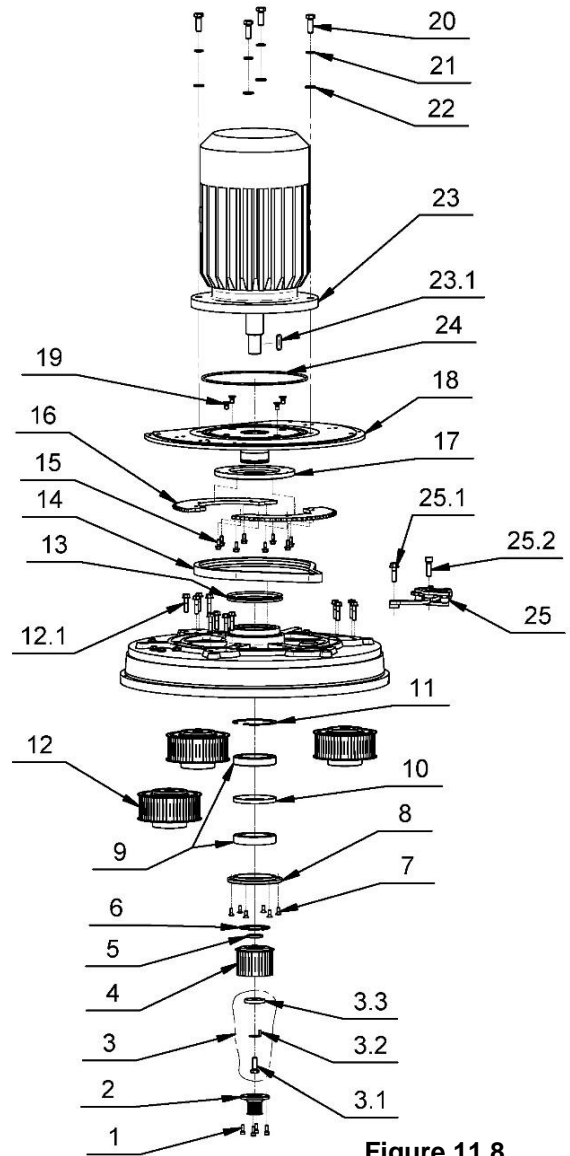

Figure 11.8

11.8 Pulley Unit Assembly

11.8 LAVINA® 25LEB,25LEHVB Pulley Unit Assembly				
No.	Item No.	Description	Pcs.	
1	L25E10.00.02-K	Front Washer Assembly	1	
	1.1	30301210035	Bolt M5X12DIN933	1
	1.2	L25E10.00.04	Washer	1
	1.3	L25E10.00.02	Front Washer	1
2	L25E16.20.00-1	Chain Pulley Assembly	1	
3	30302000032	V-Ring Type A	1	
4	L25X-16.00.00-R3	Bearing Body	1	
	4.1	30301210107	Bolt M6X25DIN6921	6
	4.2	30301260060	Key	2
	4.3	L25X-16.00.03-1	Distance Ring	1
5	L25X-04.00.00	Pulley Unit Assembly	1	
6	L25X-10.00.44	Front Washer	1	
7	30301230009	Screw M5X12DIN912	1	

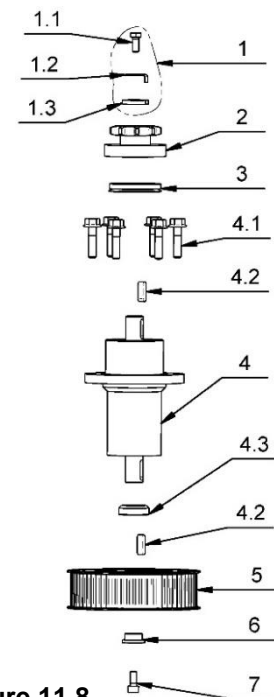

Figure 11.8

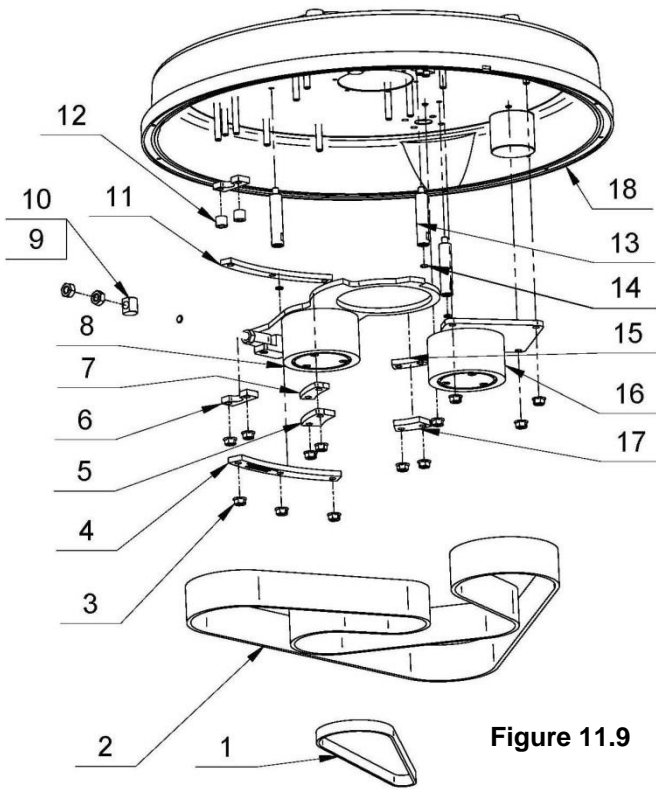

Figure 11.9

11.9. LAVINA® 25LEB,25LEHVB Bottom Cover 2 Parts			
No.	Item No.	Description	Pcs.
1	30308000152	Timing Belts	1
2	30308000130	Timing Belts	1
3	30301240095	Nut M8DIN6923	13
4	L25L-10.00.14	Sector	1
5	L25L-10.00.12	Sector	1
6	L25L-10.00.07	Support	2
7	L25L-10.00.11	Sector	1
8	L25E12.00.00	Tensioning Support	1
9	L32C-14.20.04	Nut	1
10	30301240099	Nut M10DIN934	2
11	L25L-10.00.13	Sector	1
12	L25L-10.00.08	Washer	2
13	L25X-10.00.13	Distance Bolt	3
14	30302000105	O-Ring	3
15	L25X-10.00.34	Sector	1
16	L25E13.00.00	Deflection Pulley	1
17	L25X-10.00.35	Sector	1
18	L25E10.00.01-1-K	Disc	1

Kit L25E10.00.01-1-K Replaces L25E10.00.01-K

11.10. TOOL HOLDER PARTS

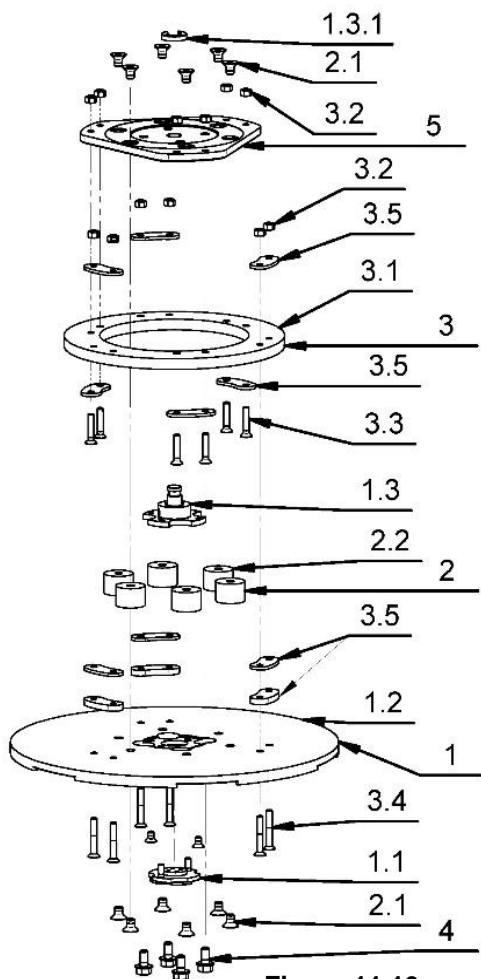

Figure 11.10

11.10. LAVINA®25LEB,25LEHVB Tool Holder Parts				
/see also fig.8.7.13/(pos.1 include pos.1.1;1.2;1.3/pos.1.3 include pos.1.3.1 and etc.)				
No.	Item No.	Description	Pcs.	
1	A63.10.00	Quick Change Assembly	1	
	1.1	A63.12.00	Keylock Set	1
	1.2	A43.11.00	Quick Change plate	1
	1.3	A41.12.00	Security set	1
		1.3.1	A41.00.05	Washer A41
2	A25.00.10-K	Buffer with two screw	6	
	2.1	30301230161	Screw M8X12DIN7991/10.9/	12
	2.2	A25.00.10	Buffer	6
3	A41.20.03-K	Driving Set A41	1	
	3.1	A41.20.03	Elastic Element	1
	3.2	30301240124	Self Locking Nut M6DIN980V	12
	3.3	30301230123	Screw M6X30DIN7991/10.9/	6
	3.4	30301230131	Screw M6X40DIN7991/10.9/	6
3.5	A41.21.00	Set of plates	1	
4	30301210072	Bolt M8x16DIN6921	4	
5	A41.20.01	Flange	1	

11.11 CARRIAGE PARTS 1

11.11 LAVINA® 25LEB/25LEHVB Carriage Parts 1							
No.	Item No.	Description	Pcs.	No.	Item No.	Description	Pcs.
1	30301230243	Screw M6x16ISO7380F-10.9	10	17	L25EB20.00.01	Pad	1
2	L20EB22.00.00	Control board assembly	1	18	MAR8.32-K	PE Tube	1
2*	L25LEHVB22.00.00	Control board assembly	1	19	30310000006	Pad	2
3	HGP270	Phone clip mount	1	20	30301240103	Nut M6DIN985	2
4	L25GE20.20.00	Left Weight	1	21	30312000043	Wheel	2
5	L20GX-20.40.00	Left Weight Support	1	21**	30312000004	Wheel	2
6	L20E20.10.00	Top Bracket	1	22	L25X-20.00.03-1	Wheel Cap	2
7	A78.00.00.00	Tank Assembly	1	22**	L32D-20.00.03	Wheel Cap	2
8	30301210051	Bolt M6X16DIN6921	4	23	30301230015	Screw M10x16DIN7991/10.9/	2
9	L25E20.50.00	Front panel	1	23**	30301230176	Screw M10x20DIN7991/10.9/	2
10	30301230251	Screw M5X16ISO7380F/10.9/	4	24	L25GE20.10.00	Right Weight	1
11	L20E20.00.03	Front cover	1	25	L20GX-20.30.00	Right Weight Support	1
12	MAR8.32-K	PE Tube	1	26	MAR8.21-K	PE Tube	1
13	30301240090	Nut M5DIN985	4	27	30301270161	Bolt M5x20 DIN603	4
14	30301221002	Washer M5DIN125A	4	28	A88.00.00	Water Valve assembly	1
15	L25LEB29.00.00	Control Box	1	29	30301210031	Bolt M8X20DIN6921	4
15*	L25LEHVB29.00.00	Control Box	1	30	30301240106	Nut M8DIN985	4
16	A89.00.00-K	Water Valve assembly	1	31	30301221004	Washer M8DIN125A	4
16.1	30301330220	Rubber sleeve	1				

* For Lavina®25LEHVB After serial No. 2204L25LEHVB1906

**The changes are for machines from serial No 2206L25LEB1001 and after serial No 2204L25LEHVB1906

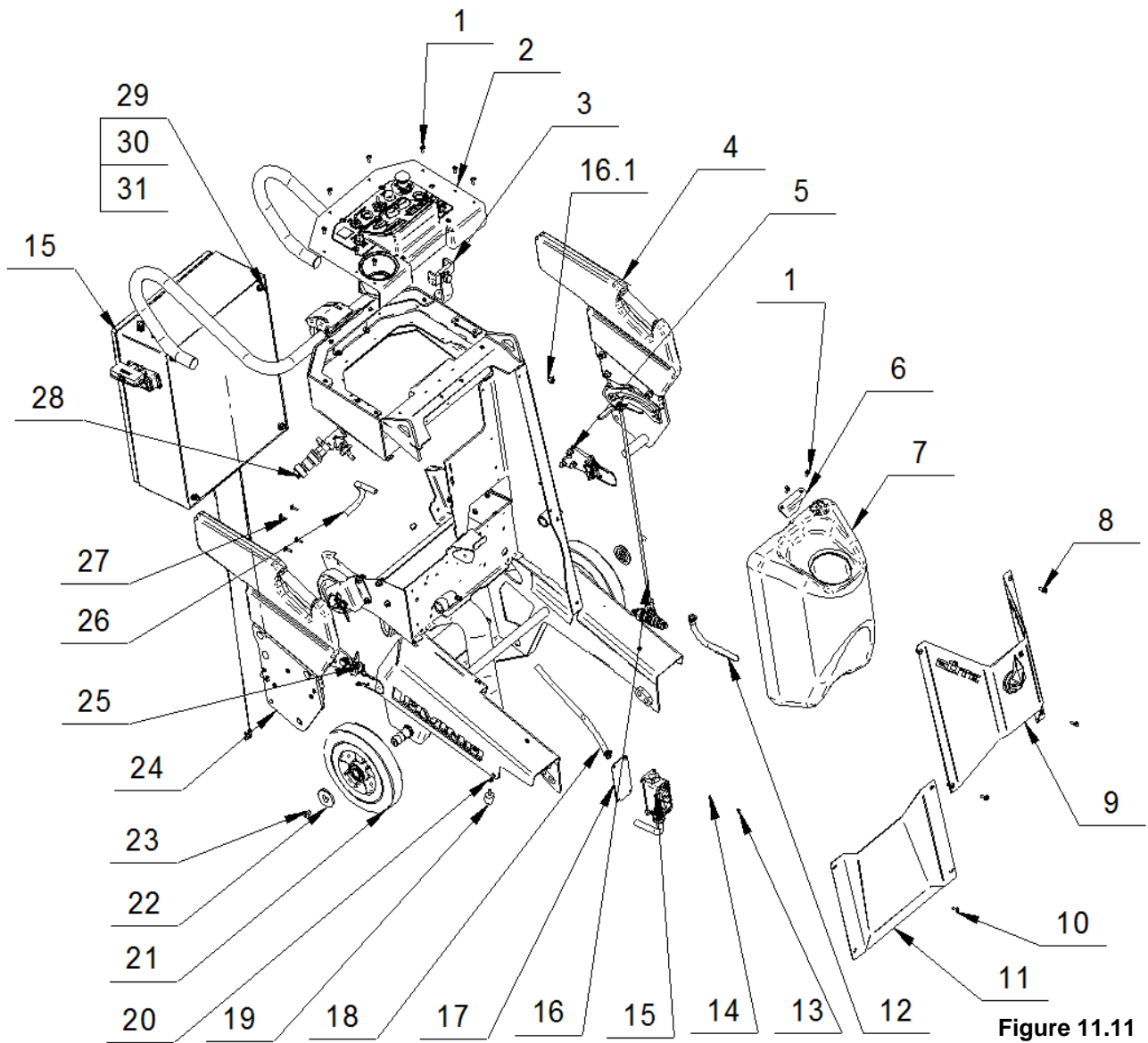

Figure 11.11

11.11.1 For machines before Serial No. 2206L25LEB1001 and No. 2204L25LEHVB1906

To replace an old wheel is ordered Wheel Kit

11.11.1 Wheel Kit			
Item No. 3031200004K			
No.	Item No.	Description	Pcs.
1	30312000004	Wheel	1
2	L32D-20.00.03	Wheel cap	1
3	30301230176	Screw M10x20DIN7991/10.9/	1

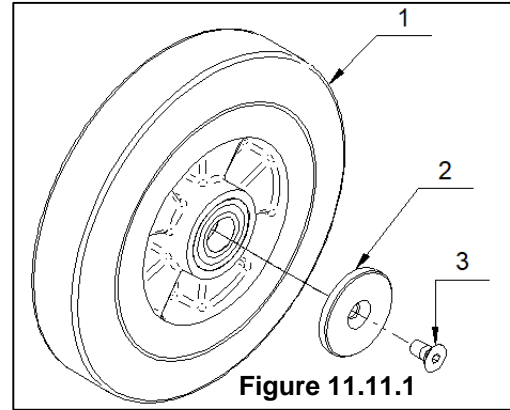

Figure 11.11.1

11.12 CARRIAGE PARTS 2

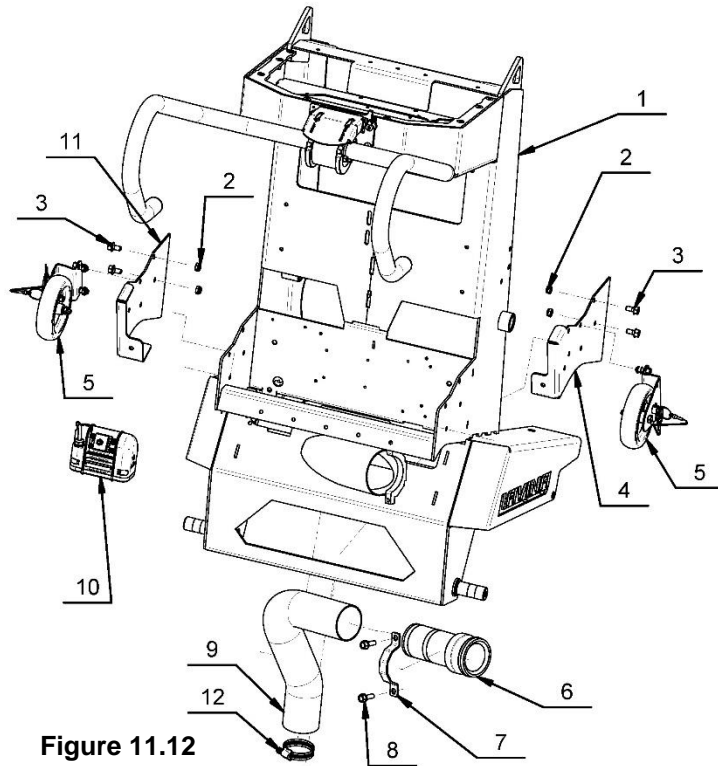

Figure 11.12

11.12. LAVINA® 25LEB,25LEHVB Carriage Parts 2			
No.	Item No.	Description	Pcs.
1	L25EB21.00.00	Frame	1
2	30301240106	Nut M8DIN985	4
3	30301210072	Bolt M8X16DIN6921	4
4	L20GX-20.00.21-2	Support right	1
5	L25E20.60.00	Wheel Assembly	2
6	E250-AL	Camlock Fitting	1
7	L25GE20.00.02	Clamp	1
8	30301210032	Bolt M8X35DIN6921	2
9	D63X470PU	Soft Vacuum Hose	1
10	UT-BS0201	LED Light	1
11	L20GX-20.00.22-2	Support left	1
12	30308000399	Clamp 50_70DIN3017	1

11.13. CARRIAGE PARTS 3

11.13. LAVINA® 25LEB,25LEHVB Carriage Parts 3				
No.	Item No.	Description	Pcs.	
1	30301240106	Nut M8DIN985	4	
2	L20GX-23.00.03	Handle support plate	1	
3	L20GX-23.00.02-1-K	Pin	1	
	3.1	30301221012	Washer M6DIN9021	2
	3.2	30301230250	Screw M6x12ISO7380-1/10.9/	2
4	L20GX-23.20.00	Handle locking bit	1	
5	30301210051	Bolt M6X16DIN6921	8	
6	L20GX-23.30.00	Handle support	1	
7	30301230257	Screw M8x30DIN7984	4	
8	L20GX-23.00.11-K	Lock Lever	1	
	8.1	30301210109	Bolt M5x14DIN933	1
	8.2	30301221002	Washer M5DIN125A	1
9	L30LE21.10.00	Handle Assembly	1	
10	L20GX-23.00.01	End Cover	2	

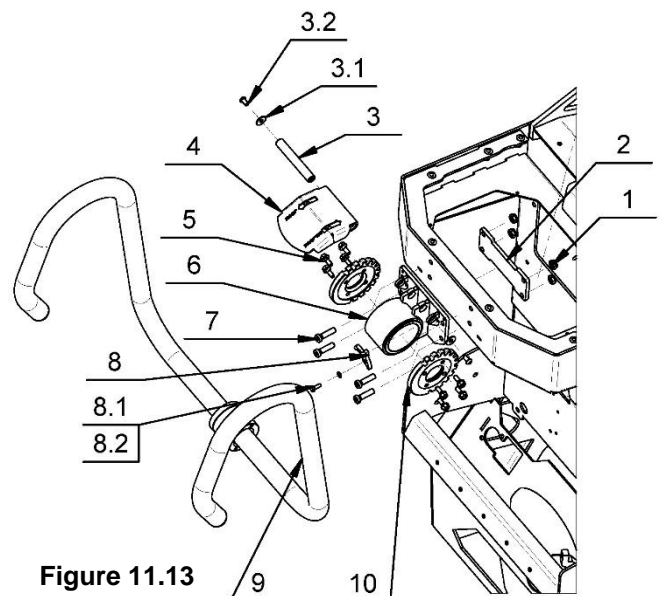

Figure 11.13

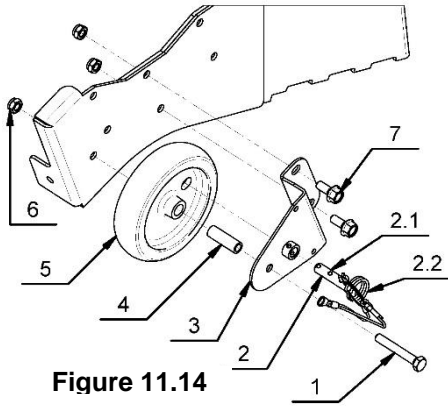

Figure 11.14

11.14. LAVINA® 25LEB,25LEHVB WHEEL ASSEMBLY

Item No. L25E20.60.00

No.	Item No.	Description	Pcs.
1	30301210005	Bolt M8X55DIN933	1
2	L25E20.62.00	Pin Assembly	1
	2.1	Pin	1
	2.2	Accessories	1
3	L25E20.61.00	Housings	1
4	L25E20.60.03	Bushing	1
5	L25E20.60.01	Wheel	1

11.15. Water Tank

11.15 LAVINA® 25LEB,25LEHVB WATER TANK

Item No. A78.00.00.00

No.	Item No.	Description	Pcs.
1	A33-00.02-K	Water Tank-K	1
2	3031600001	Filter	1
3	3031600015	Nipple	1

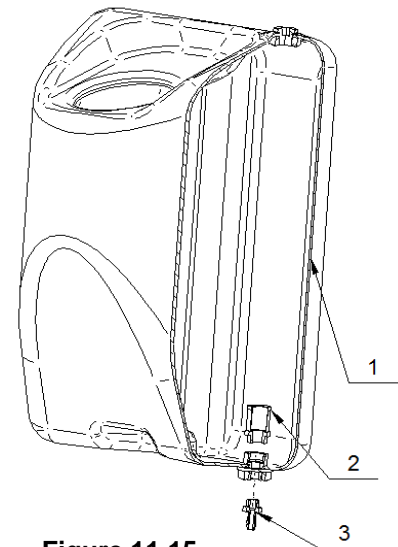

Figure 11.15

11.16 EXTERNAL WATER VALVE

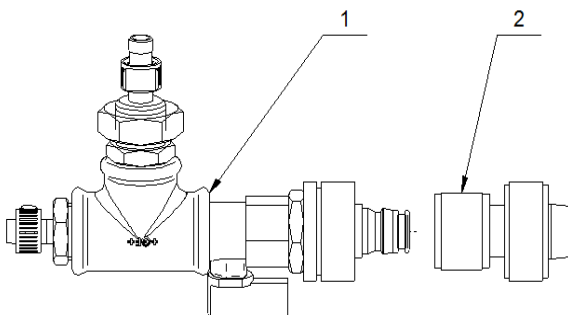

Figure 11.16

11.16 LAVINA® 25LEB,25LEHVB EXTERNAL WATER VALVE

Item No. A88.00.00

No.	Item No.	Description	Pcs.
1	A88.00.00-K	Water ball valve kit	1
2	30316000013	Quick-change nozzle	1

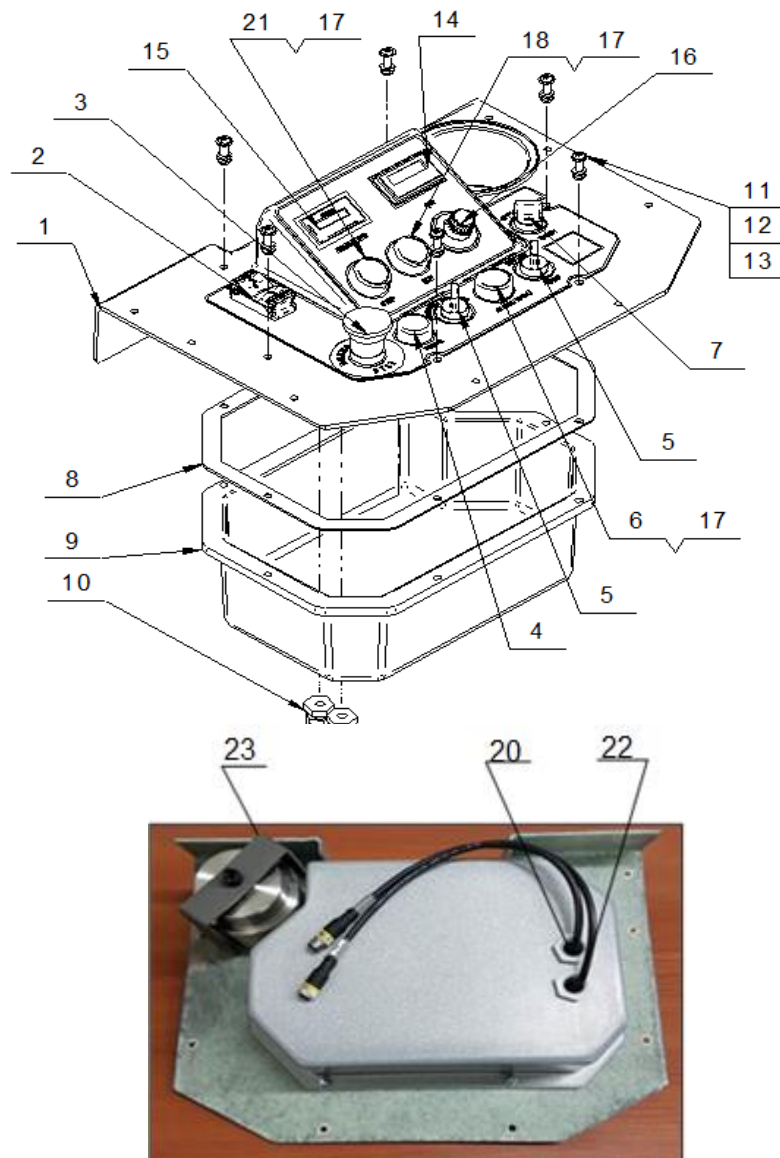

Figure 11.17

11.17 LAVINA25LEB,25LEHVB CONTROL BOARD ASSEMBLY							
Item No. L20EB22.00.00							
No.	Item No.	Description	Pcs.	No.	Item No.	Description	Pcs.
1	L20EB22.10.00	Control board assembly kit	1	12	30301221003	Washer M6DIN125	6
1*	L25LEBHV22.10.00	Control board assembly kit	1	13	30301240103	Nut M6DIN985	6
2	30313000173	USB charger	1	14	30313000150	Tachometer	1
3	30311000717	EMG Button	1	15	30313000153	Hour meter	1
4	30311000740	Power glowing Green	1	16	30311000690	Potentiometer	1
5	30311000721	Switch	2	17	30311000750	Cap	3
6	30311000730	Бутон	1	18	30311000701	Button	1
7	30311000732-K	Switch	1	19	30350000045	Cup holder	1
8	30302000145	Seal	1	20	L20E22.22.00	L20E Cable X2 control	1
9	L25E22.00.02	Box	1	21	30311000700	Button	1
10	30311000401	Cable Gland 16x1,5	2	22	L20EB22.21.00	L20EB Cable X1 control	1
11	30301230264	Screw	6	23	L20GX-40.20.03	Clamp	1

* For Lavina®25LEHVB item No. L25LEHVB22.00.00

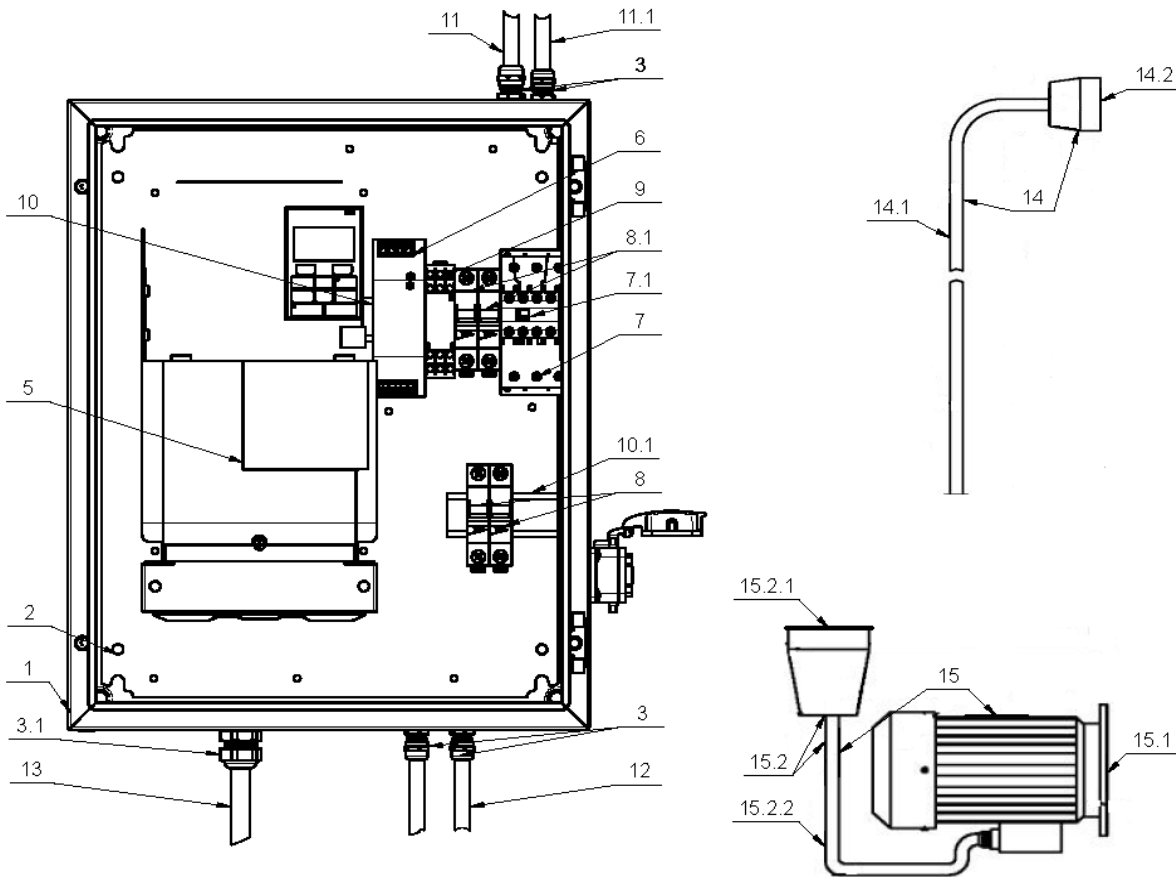

Figure 11.18

11.18 Lavina 25LEB CONTROL BOX PARTS 200-240 V							
No.	Item No.	Description	Pcs.	No.	Item No.	Description	Pcs.
1	L25LEUB25.20.01	Metal box (only)	1	10.1	L32EHV25.20.03	Rail L=85 H=7,5	1
2	L25E25.20.01	Metal plate (only)	1	11	L20EB25.51.00	Cable X1	1
3	30311000401	Cable gland M16x1,5	4	11.1	L20E25.54.00	Cable X2	1
3.1	30311000405	Cable gland M25x1,5	1	12	L32E25.30.00	Cable for front lamp	1
4	L25LE30.30.30	Connector	1	13	L25LE25.30.00	Output cable from Invertor	1
5	30313000102	Invertor	1	14	L25LS-30.02.00	Cable with connector	1
6	30313000190	Power supply	1	14.1	L25S-30.02.02	Cable	1
7	30311000197	Contactor	1	14.2	L25LS-30.02.10	Connector	1
7.1	30311000198	Additional contact	1	15	L25LE18.00.00	Electro motor assembly	1
8	30311000612	Circuit breaker 2A 1P	2	15.1	S255	Electro motor	1
8.1	30311000600	Circuit breaker 4A 1P	2	15.2	L25LE18.10.00	Cable with plug	1
9	30311000191	Over voltage relay	1	15.2.1	L25LE18.12.00	Plug	1
10	L20NE25.20.02	Rail L=150 H=7,5	1	15.2.2	L25LE18.11.00	Cable	1

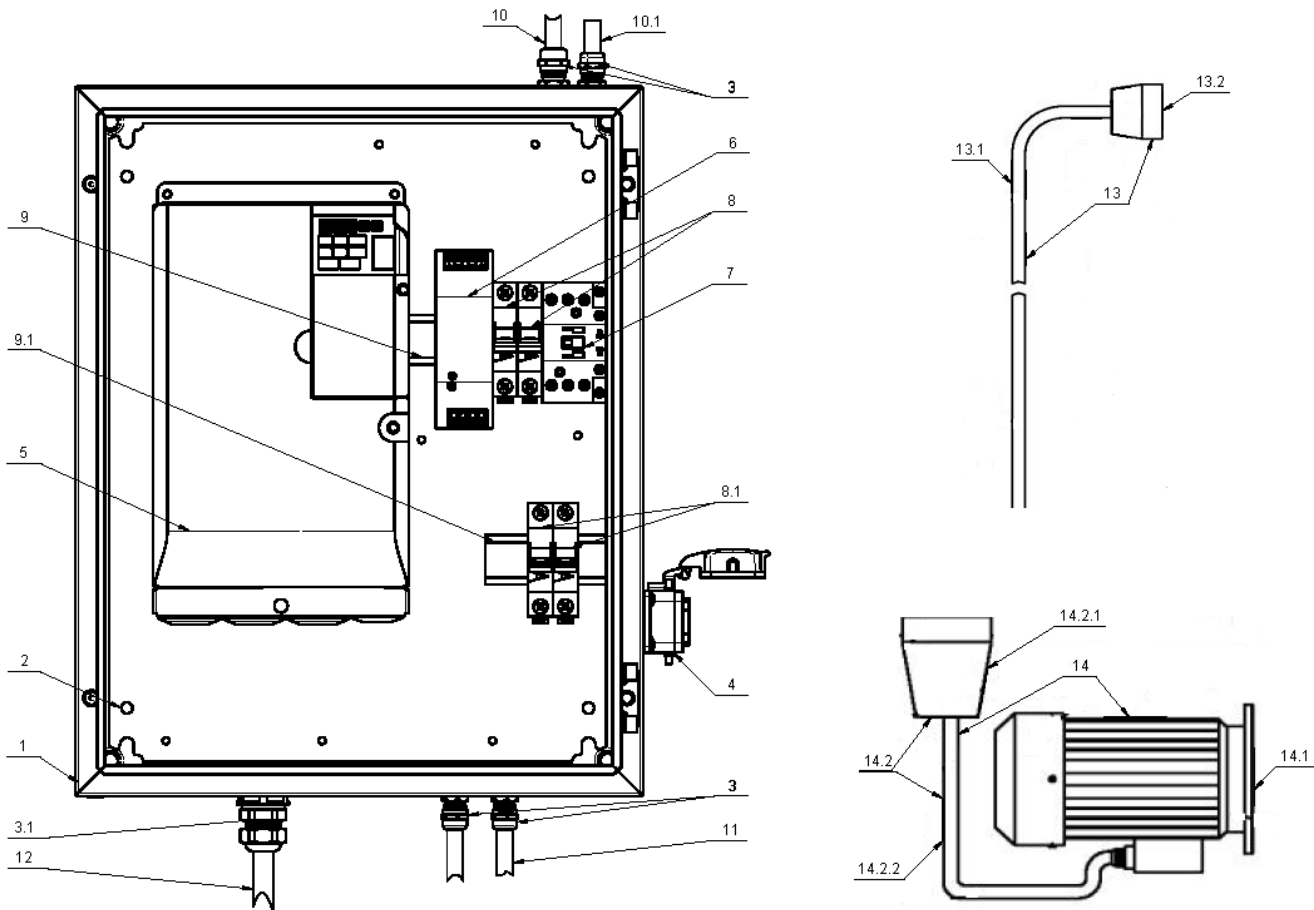

Figure 11.19

11.19 Lavina 25LEHVB CONTROL BOX PARTS 400-480V.							
No.	Item No.	Description	Pcs.	No.	Item No.	Description	Pcs.
1	L25LEUB25.20.01	Metal box (only)	1	10	L20EB25.51.00	Cable X1	1
2	L25E25.20.01	Metal plate (only)	1	10.1	L20E25.54.00	Cable X2	1
3	30311000401	Cable gland M16x1,5	4	11	L32E25.30.00	Cable for front lamp	1
3.1	30311000405	Cable gland M25x1,5	1	12	L25LEU25.40.00	Output cable from Invertor	1
4	L25E30.02.00	Socket	1	13	L25LEHV40.00.00	Cable with connector	1
5	30313000105	Invertor	1	13.1	L25LEHV40.10.00	Cable	1
6	30313000190	Power supply	1	13.2	L32SHV-30.70.10	Connector	1
7	30311000189	Contactor	1	14	L25LEU18.00.00	Electro motor assembly	1
8	30311000600	Circuit breaker 4A 1P	2	14.1	S255	Electro motor	1
8.1	30311000612	Circuit breaker 2A 1P	2	14.2	L25LEU18.10.00	Cable with plug	1
9	L20NE25.20.02	Rail L=150 H=7,5	1	14.2.1	L32SHV-30.20.11	Plug	1
9.1	L32EHV25.20.03	Rail L=85 H=7,5	1	14.2.2	L25LEU18.10.10	Cable	1

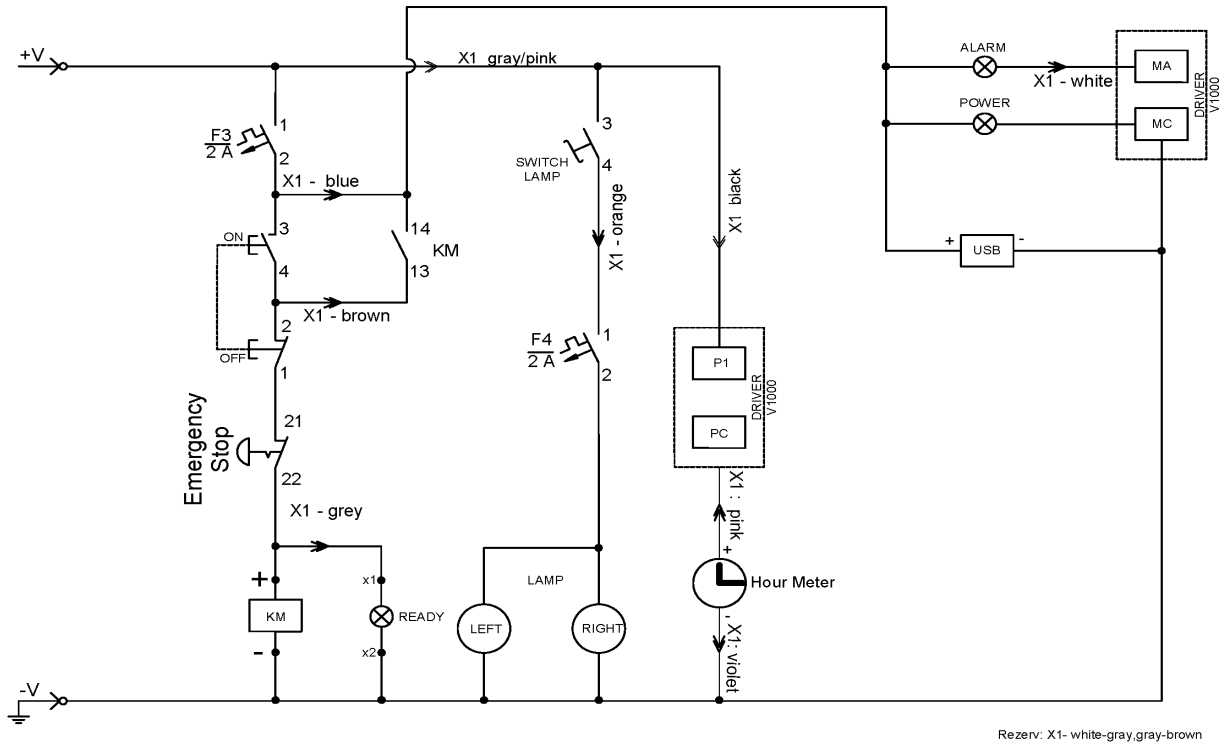

Figure 11.20.4 /scheme 3 – L25LEB /

**LAVINA® 25LEHVB ELECTRICAL SCHEMES WITH YASKAWA INVERTER
400-480 Volt**

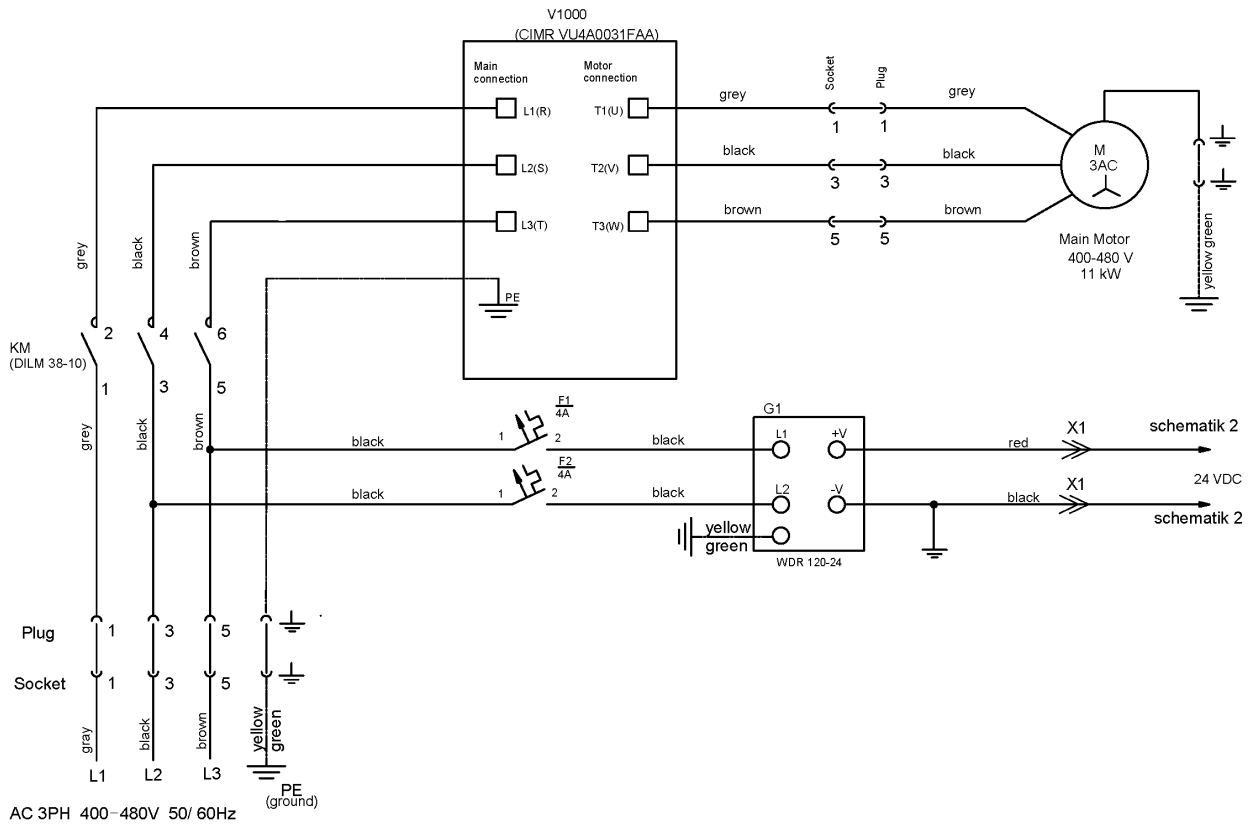

Figure 11.20.5 /scheme 1 – L25LEHVB /

LAVINA® 25LEHVB ELECTRICAL SCHEMES YASKAWA CONNECTION MAIN CIRCUIT TERMINALS

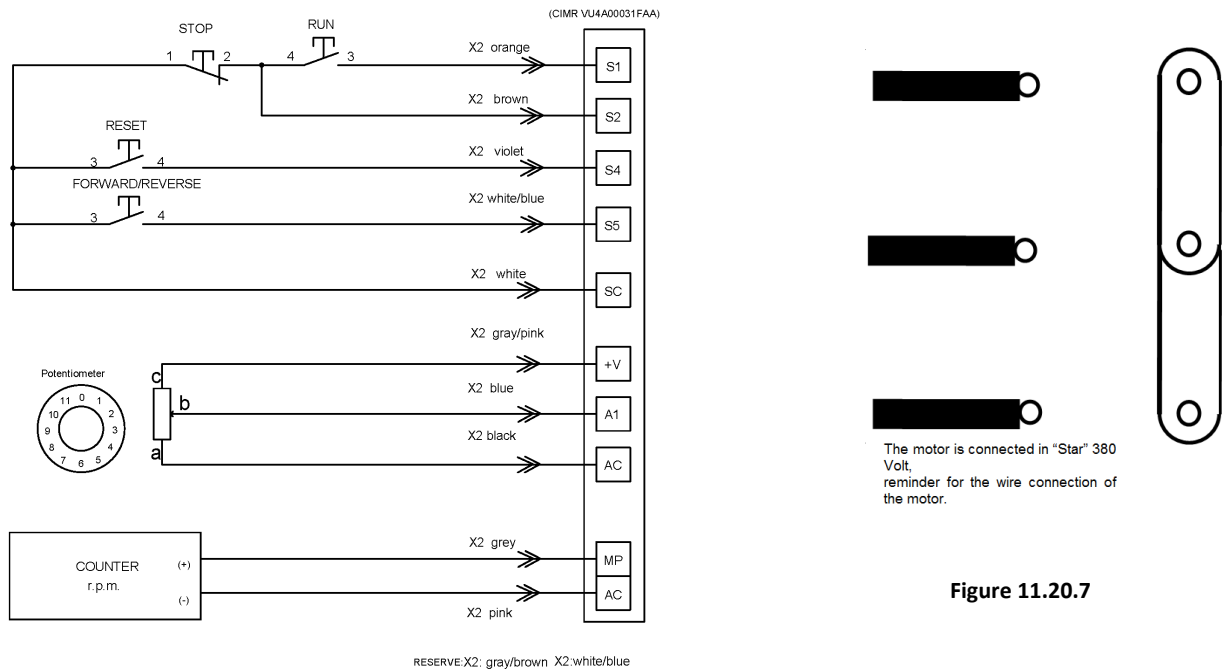

Figure 11.20.7

Figure 11.20.6 /scheme 2- L25LEHVB /

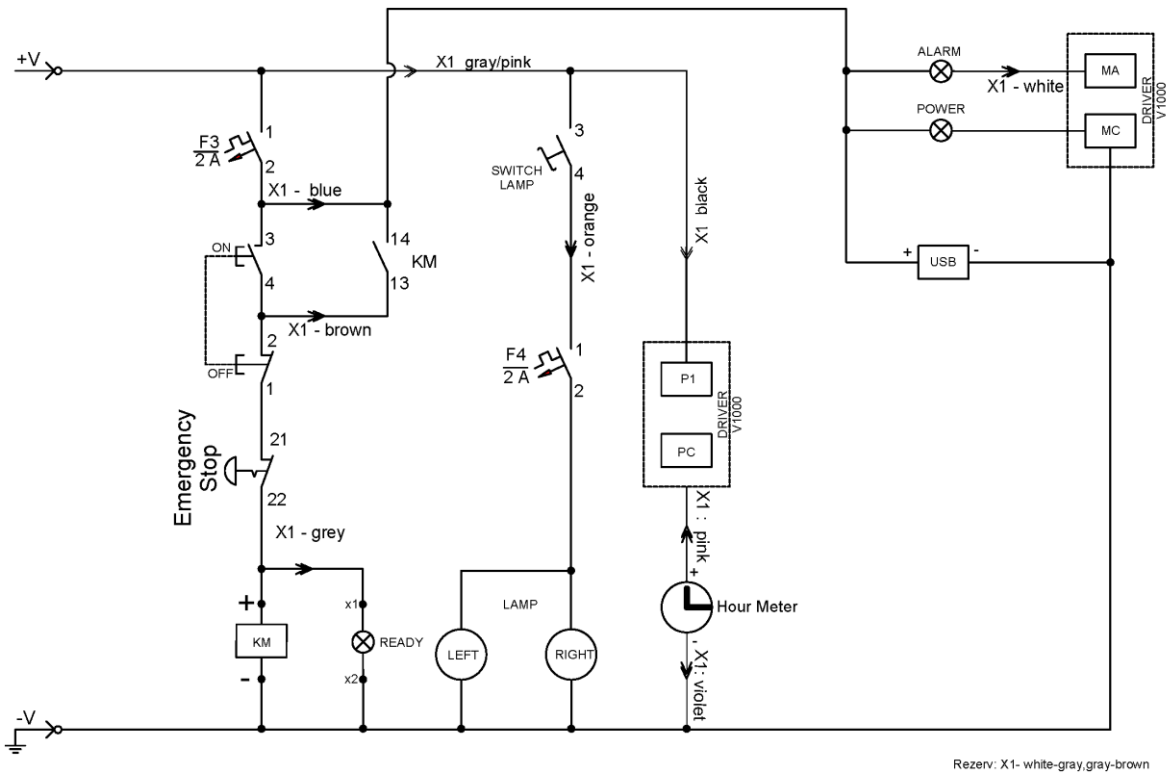

Figure 11.20.8 /scheme 3 - L25LEHVB /