

LAVINA®



LAVINA® V20E USER MANUAL



Tech Support Line: 800-987-8403 | www.superabrasive.com | info@superabrasive.us



Warranty Registration Card

Complete and submit this form within 30 days from the date of purchase. The registration is invalid without the machine serial number.

Section 1: Customer Information

Customer name

Address

City

State and Zip Code

Phone #

Email

Section 2: Machine Information

LAVINA model

Serial #

Purchase Date

Purchased From (distributor, dealer)

*Email: warranty@superabrasive.us / Fax: 706-658-0357
Superabrasive Inc., 9411 Jackson Trail Rd, Hoschton, GA 30548*

Contents

1. WARRANTY AND RETURNS.....	5
1.1 WARRANTY POLICY FOR LAVINA® V20E.....	5
1.2 RETURN POLICY FOR LAVINA® VACUUMS.....	6
2. GENERAL INFORMATION.....	7
2.1 MANUFACTURER.....	7
2.2 GENERAL DESCRIPTION.....	7
3. MAIN COMPONENTS AND CONTROLS.....	8
4. TECHNICAL DATA.....	9
5. SAFETY PRECAUTIONS.....	10
5.1 RECOMMENDED USE.....	10
5.2 PROHIBITED USE.....	10
5.3 PREPARATION FOR WORK.....	10
5.4 STOP FUNCTIONS.....	10
5.5 SAFE USE.....	10
5.6 BEFORE YOU BEGIN.....	10
5.7 OPERATING THE VACUUM.....	11
5.8 AFTER WORK IS COMPLETED.....	11
5.9 THE WORK AREA.....	11
5.10 PERSONAL PROTECTIVE EQUIPMENT (PPE).....	11
5.11 OPERATOR.....	11
6. UNPACKING, HANDLING, TRANSPORTATION AND STORAGE.....	13
7. OPERATING WITH THE VACUUM.....	14
7.1 LOCKING CASTER WHEEL.....	14
7.2 MAIN FILTER CLEANING.....	15
7.3 MAIN FILTER CHANGE.....	16
7.4 HEPA FILTER CHANGE.....	17
7.5 LONGOPACK® BAG REPLACEMENT (CHANGING BAGS).....	19
7.6 INSTALLING LONGOPAC® REFILL PACKS.....	20
8. MAINTENANCE AND INSPECTION.....	21
8.1 LAVINA® V20E ELECTRIC CIRCUIT DIAGRAM.....	22
8.2 VACUUM MOTORS SERVICING.....	23
8.3 FILTER CHAMBER FLAP REPLACEMENT.....	24
9. TROUBLESHOOTING.....	25
10. LAVINA® VACUUM ADAPTERS AND CONNECTIONS.....	26
11. SPARE PARTS.....	27

- 11.1 GENERAL PARTS..... 27
- 11.2 VACUUM HEAD COVER..... 29
- 11.3 MAIN FILTER CHAMBER..... 31
- 11.4 INLET VALVE 32
- 11.5 CARRIAGE 33
- 11.6 POWER UNIT..... 35
- 11.7 CONTROL BOARD 37
- 11.8 VACUUM GAUGE ASSEMBLY 40
- 12. ACCESSORIES 41
- 13. DISPOSAL 42
- 14. MANUFACTURER’S CONTACTRS..... 42
- 15. CE-RECERTIFICATION 42
- 16. EMMISION CONTROL WARRANTY STATEMENT 43

1. WARRANTY AND RETURNS

1.1 WARRANTY POLICY FOR LAVINA® V20E

If your warranty card is missing, contact your local distributor and request a warranty card, or visit us at www.superabrasive.com to download one. The customer is responsible for filling out the card and mailing it to the manufacturer's address as indicated on the card. To ensure registration and activation of warranty coverage, the warranty card must be mailed to the manufacturer within 30 days from date of purchase; failure to do so may void the warranty. Be sure to provide the manufacturer with all of the information requested, and most importantly with the distributor's name, machine serial number, and purchase date.

Superabrasive offers a guarantee on LAVINA® vacuums, covering manufacturing and material defects, for a period of 24 months from the date of purchase, as invoiced by Superabrasive. The following conditions pertain to this warranty:

- Applies only to the original owner and is not transferable.
- Vacuum must not be dismantled and tampered with in any way.
- This warranty does not cover any failures or defects caused by normal wear and tear, accidental damage, damage during transport, improper handling, repairs conducted by an unauthorized facility (without prior authorization by Superabrasive), or operation that is not in compliance with the instructions provided in this manual. Superabrasive denies all responsibility for damages or injuries, to any persons or objects, caused by improper operation of the vacuum unit.
- This warranty will become invalid in the event that equipment or accessories used on/with the vacuum unit are not supplied or approved by Superabrasive.
- Covered components proven defective will be repaired or replaced at no charge.
- This warranty does not apply to any repair of/to of proprietary parts, nor does it cover cleaning or general maintenance.
- This warranty does not apply to items with aftermarket alterations, changes, or modifications.
- This warranty is limited to repair or replacement of covered components and reasonable labor expenses.
- In the event of a warranty claim, the vacuum unit must be returned to Superabrasive, or an authorized facility, for a warranty investigation, and subsequent warranty repair or replacement.
- All warranty returns must be shipped freight prepaid.
- This warranty is in lieu of and excludes every condition of warranty not herein expressly set out and all liability for any form of consequential loss or damage is hereby expressly excluded.

The above warranty conditions may be changed only by Superabrasive. Superabrasive reserves the right to inspect and make a final decision on any machine returned under this warranty. This warranty applies to new, used, and demo machines.

Superabrasive agrees to repair or replace, free of charge, any parts which have failed due to manufacturer or material defects. Repairs must only be performed at authorized service facilities that have been approved by Superabrasive. Shipping and handling fees associated with warranty claims must be pre-paid by the customer / claimant.

In the event that a warranty investigation determines that the damage or unit failure is not attributed to manufacturer or material defects, all costs associated with the repair of the vacuum will become the direct responsibility of the claimant. If payment is not rendered for such services, Superabrasive will assume ownership of the machine and any associated parts in possession.

Superabrasive does not authorize any person or representative to make any other warranty, or to assume for us any liability in connection with the sale and operation of our products.

The manufacturer is also not liable in the event that the customer fails to submit a Warranty Certificate, fails to follow manual instructions, uses non-original spare parts, or fails to service/clean the vacuum regularly and properly

1.2 RETURN POLICY FOR LAVINA® VACUUMS

LAVINA® Vacuums may be returned, subject to the following terms:

- Vacuums may not be returned to Superabrasive Inc. for credit or repair without prior authorization. Please contact Superabrasive Inc. or your local distributor for authorization and issuance of a return authorization number. This number along with the serial number of the vacuum must be included on all packages and correspondences. Vacuums returned without prior authorization will remain property of the sender and Superabrasive Inc. will not be responsible for these.
- No vacuums will be credited after 90 days from the date of Superabrasive's invoice.
- All returns must be shipped freight prepaid. All returns may be exchanged for other equipment or parts of equal dollar value. If vacuums are not exchanged, they are subject to a fifteen percent (15%) restocking fee.

2. GENERAL INFORMATION

This owner's manual is intended for the operator of the Lavina® V20E machine, the servicing technician as well as for anyone involved with operating or servicing the machine. We recommend that you read the instructions very carefully and follow them strictly. The manual includes information about assembling, using, handling, adjusting and maintaining your Lavina® V20E concrete dust collector.

2.1 MANUFACTURER

Superabrasive was founded in 1987, as a manufacturer of high quality diamond tools for the stone and concrete industry. Today, Superabrasive is one of the world's leading companies in the production of diamond tools and floor grinding machinery. At Superabrasive, we strive to deliver the very best solutions to our customers, and enable them to work more efficiently.

2.2 GENERAL DESCRIPTION

Lavina® V20E dust collector is designed for sucking and separating dry, non-combustible and non-explosion dust. Dust laden air is sucked through at high speed via the suction hose. The air is slowed down by the cyclone and coarse dust particles are separated out, partly by centrifugal force and partly by gravity. Air and finer particles then pass through filter system from the primary filter and the HEPA filter where the dust is separated. The machine is designed to clean the primary filter by impulse reverse air flow. The separated dust accumulates in the cyclone until you close the valve situated on the vacuum's hood to discharge the dust from the body or the machine is switched off. Either way the dust drops through the bottom flap into the plastic bag.

Lavina® V20E dust collector has one hose:

- Main hose with cuff for the wand;

WARNING!

The dust collector Lavina® V20E is manufactured and fitted for the above-mentioned applications only! Every other use may possess risks to the persons involved.

3. MAIN COMPONENTS AND CONTROLS

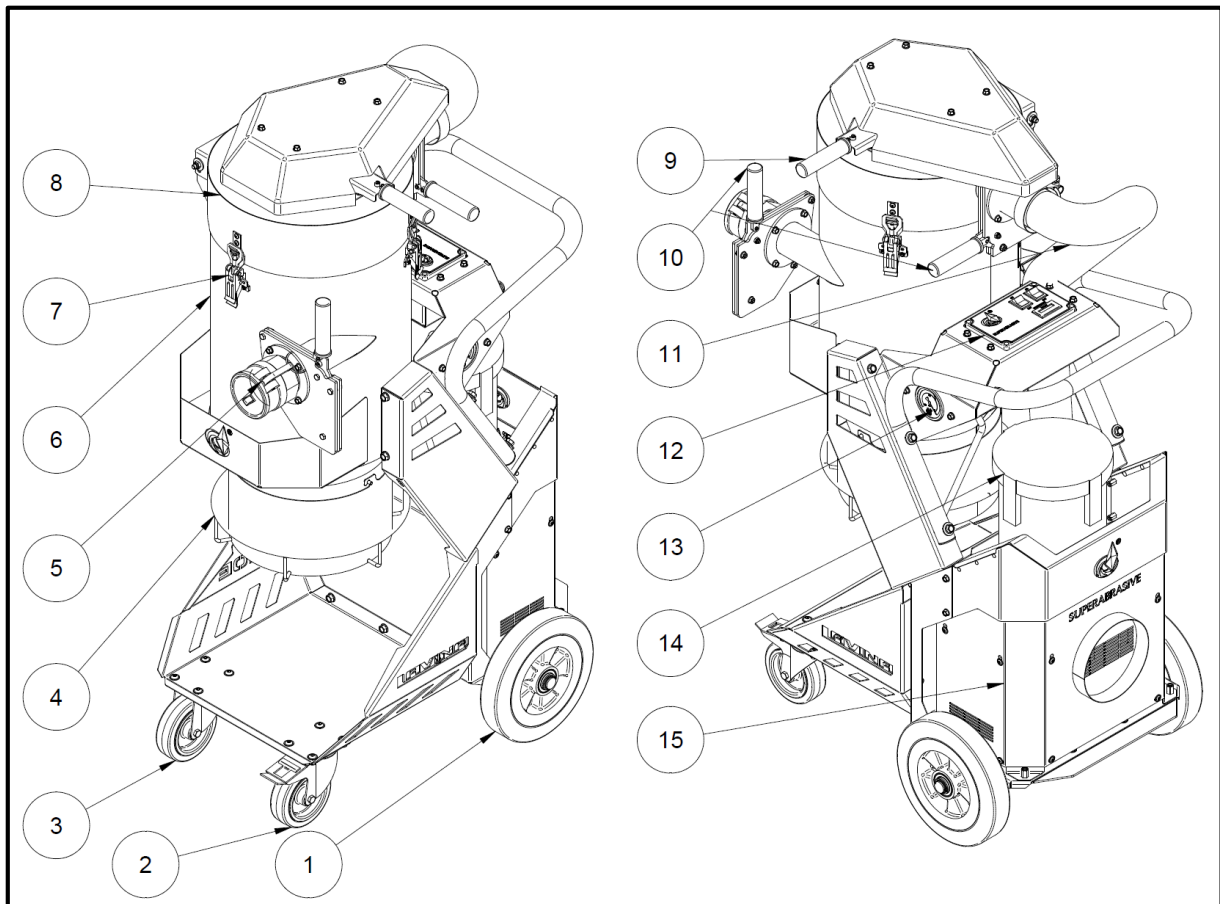

Figure 3.1

- | | |
|---------------------------------------|--|
| 1. Fixed wheel (2 total); | 9. Handle for jet pulse filter cleaning system; |
| 2. Caster locking wheel; | 10. Valve (2 total – one for jet pulse filter cleaning and one for dust discharge); |
| 3. Caster wheel; | 11. 3" intermediate hose; |
| 4. Holder for LONCOPAC® waste system; | 12. Control board |
| 5. Vacuum hose Camlock inlet; | 13. Vacuum pressure gauge; |
| 6. Filter chamber; | 14. HEPA filter chamber; |
| 7. Latches (3 total); | 15. Vacuum motors chamber; |
| 8. Vacuum head cover; | |

The control board pos.12 contains two lighted power switches and an hour meter.

Label Data - The data on the label provides the correct kW, weight and dimensions; Weight (needed for transportation purposes); production year and serial number (needed for maintenance purposes).

Customer Service - For customer assistance and technical support call your local distributor or call Superabrasive Inc. at 1-800-987-8403 or visit us at www.superabrasive.com , where you can download a copy of this manual.

4. TECHNICAL DATA

Table 4.1

Model version		V20E115	V20E230	V20EU
Voltage/Hz		1phx115V50/60Hz	1phx230V50/60Hz	1phx230V50/60Hz
Power	kW	1.93kW	2.4kW	2.4kW
	HP	2.6HP	3.3HP	3.3HP
Amperage	Amps	15.4 Amps	13 Amps	13 Amps
Filter		CONICAL FILTER	CONICAL FILTER	CONICAL FILTER
Filter surface	m ²	3 m ²	3 m ²	3 m ²
	ft ²	32 ft ²	32 ft ²	32 ft ²
Filter cleaning		Manual	Manual	Manual
HEPA filter area	m ²	2m ²	2m ²	2m ²
	ft ²	21.5 ft ²	21.5 ft ²	21.5 ft ²
Longopac		YES	YES	YES
Main hose	mmxm	50mmx7.5m	50mmx7.5m	50mmx7.5m
	inxft	2inx24ft	2inx24ft	2inx24ft
Hose for wand	mmxm	50mmx6.6m	50mmx6.6m	50mmx6.6m
Motors		2 bypass motors	2 bypass motors	2 bypass motors
Airflow (max)	m ³ /h	330	437	357
	CFM	194	257	210
Vacuum max	bar	0.22	0.22	0.22
	(inchH ₂ O)	88	88	88
Dimensions (L*W*H)	mm	830x585x1385	830x585x1385	830x585x1385
	in	32.7x23x54.5	32.7x23x54.5	32.7x23x54.5
Weight	kg	80kg	80kg	80kg
	lbs	176lbs	176lbs	176lbs

5.SAFETY PRECAUTIONS

5.1 RECOMMENDED USE

The LAVINA® V20E vacuum is designed and manufactured for use with concrete, terrazzo and natural stone floors. It is recommended for use with LAVINA® machines. This vacuum is rated for dry use only, and with a machine of appropriate size. For more information, please contact Superabrasive.

5.2 PROHIBITED USE

The vacuum MUST NOT be used:

- For applications different from those stated in this manual;
- For collecting non-suitable materials (asbestos or other toxic materials);
- In environments which (1) Possess the risk of explosion, (2) Possess high concentration of powders or oil substances in the air, (3) Possess the risk of fire, (4) Feature inclement conditions, (5) Possess electromagnetic radiation;

5.3 PREPARATION FOR WORK

Ensure that:

- You have secured the working area, so that no person unfamiliar with operating the vacuum can enter the area;
- The vacuum is not missing parts;
- The vacuum is in an upright, working position;
- All protection devices are working properly;

5.4 STOP FUNCTIONS

Functions for arresting of the machine include following:

- Three buttons to stop each motor separately;

5.5 SAFE USE

The LAVINA® V20E is designed to eliminate all potential risks associated with its use. However, accidents may occur if unskilled or uninstructed workers fail to heed the list of potential risks below:

- Position Risks due to operator's incorrect working position;
- Tangling Risks due to wearing inappropriate working clothes;
- Training Risks due to lack of operational training;

NOTE: Machine operators should follow the instructions in the manual at all times.

RESIDUAL RISKS During normal operating and maintenance cycles, the operator is exposed to some.

5.6 BEFORE YOU BEGIN

- The working area must be clear from any debris or objects.
- A first-time operator must always read the manual and heed all safety instructions.

- Perform general daily inspections of the vacuum and inspect the vacuum before each use for any sign of damage.
- Inspect all safety devices.
- The vacuum/filters must be clean and the hose should be connected.

5.7 OPERATING THE VACUUM

When operating the LAVINA® V20E, be sure that no one else is within close proximity to the vacuum. Never leave the vacuum unattended while working. The hose must move freely, be damage-free, and should never run beneath the vacuum or machine. Check the floor prior to beginning any work, and ensure that it's not too uneven, which can cause damage to the vacuum.

5.8 AFTER WORK IS COMPLETED

When work is complete, clean the vacuum and its surroundings sufficiently, empty all dust / debris, secure the hose, and store the vacuum in a safe and secure place.

5.9 THE WORK AREA

Ensure that the area is free of unauthorized people or vehicles, hoses, and always check the floor for debris.

5.10 PERSONAL PROTECTIVE EQUIPMENT (PPE)

When operating the machine, always wear safety shoes, ear protectors, safety gloves (especially when changing tools), and suitable clothing. All persons within the immediate working area must wear safety glasses with side shields.

5.11 OPERATOR

The operator must be aware of the vacuum's work environment, be properly trained prior to operating the equipment, and fully understand this manual. Only one operator may work with the machine at a single time. The operator must understand and interpret all the drawings and designs in manual, understand all sanitation and safety regulations pertaining to its operation, have floor grinding experience, know how to perform in an emergency situation, and have an adequate technical knowledge.

- The dust collector should only be operated in environments with a temperature between 41°F and 113°F (5°C to 45°C) and a maximum relative humidity of 70%.
- The work environment for the vacuum should be clean, well-lit, and free of combustible elements.
- The dust collector should not be operated without the proper filters installed. This could possibly result in damage to the machine, and cause harm to surrounding personnel.
- Do not open the waste container or motor head assembly while the vacuum is operating.
- Do not vacuum any flammable materials or substances such as fuels, solvents, etc. A dust collector must be specifically designed and labeled for such operation. When grinding epoxy, first ensure that the epoxy is non-toxic.
- Do not vacuum any corrosive substances unless the vacuum is specifically outfitted with containers suitable for this purpose.
- Do not vacuum any burning, smoldering, or hot materials. This could result in a possible explosion and/or damage to the vacuum components.

- If toxic or harmful substances accidentally enter the vacuum cleaner, the container and filters must be removed and cleaned immediately using the proper protective equipment and safety procedures.
- Utilize the locking caster wheel to prevent movement while work is being performed.
- When moving the dust collector, never pull on the vacuum hose. For this purpose, always use the designated handles mounted on the machine.
- For this specific dust collector, sound tests indicate that the emitted noise level is measured at a maximum of 70 decibels (dBA), for a distance of 1 meter from the machine (and height of 1.60 meters). The vibrations emitted from the machine have been measured at a maximum value of 2.5 m/s². • CAUTION: The National Institute for Occupational Safety and Health (NIOSH) recommends that exposure to noise in the working environment be maintained below a level equivalent to 85 dBA for a period of eight hours, in order to minimize occupational, noise induced hearing loss. Any persons working in proximity of the vacuum cleaner should wear the proper hearing protection in order to prevent hearing loss. Please refer to your local laws and regulations for further information on the matter.
- When storing the vacuum, the filter should be removed and cleaned, and the waste container should be emptied of debris. Store the vacuum in temperatures between 32°F and 104°F (0°C and 40°C). Cover the vacuum in order to protect it from accumulating debris and/ or environmental elements.

6. UNPACKING, HANDLING, TRANSPORTATION AND STORAGE

When unpacking the machine, please check that the following accessories are included:

- The hose end fitting;
- Steel wand;
- Floor brush;
- Main vacuum hose with cuff to connect to the machine;

If any of the above-mentioned parts are missing, please contact your local distributor or our sales representative. Protect the environment: Please dispose of packaging materials and used machine components in an environmentally safe way according to local disposal regulations.



Figure 6.1



Figure 6.2



Figure 6.3

Attention

When handling and transporting the machine, never use the handles or other machine parts to lift the machine. Use always a skid or pallet for transportation, and never transport an unprotected machine in the rain or snow. Always store and transport the machine in an upright position. The machine should also always be stored in a dry, frost-proof environment.

7. OPERATING WITH THE VACUUM

IMPORTANT: Before connecting the power cord to the power source, ensure that the electrical voltage corresponds with the requirements identified on the information plate on the vacuum cleaner. Make sure that the flexible vacuum hose is securely attached to vacuum cleaner inlet. Inspect the power cable (and extension cords) for any signs of wear or damage. Replace if necessary. Toggle the motor switches to the “1” position to turn on the motors, and “0” position to turn them off.

CAUTION: Before switching the dust collector motors “on,” always make ensure that they are at a complete rest before energizing. Also, before connecting the power supply, be sure the “start” switches are down.

TO START THE VACCUM: The vacuum is equipped with two ON/OFF buttons - one for each motor (fig. 7). In order to turn it on – press the buttons to “1” position. When a button is on its “ON” position, it glows in red. To turn it off – respectively turn the button to its “0” position.

The vacuum is equipped with an hour meter, which shows the working hours.



Figure 7

7.1 LOCKING CASTER WHEEL

There is one locking caster wheel located on the front of the dust collector. Locking the wheel will prevent the vacuum from moving, and possibly causing damage or injury. The wheel should be locked on uneven surfaces to prevent unexpected rolling or movement. To lock or unlock the caster wheel, follow the procedure shown below.

- To lock the caster wheel, press down on the metal tab
- To unlock the caster wheel, press backwards on the metal tab protruding from the top of the wheel assembly.



Figure 7.1

7.2 MAIN FILTER CLEANING

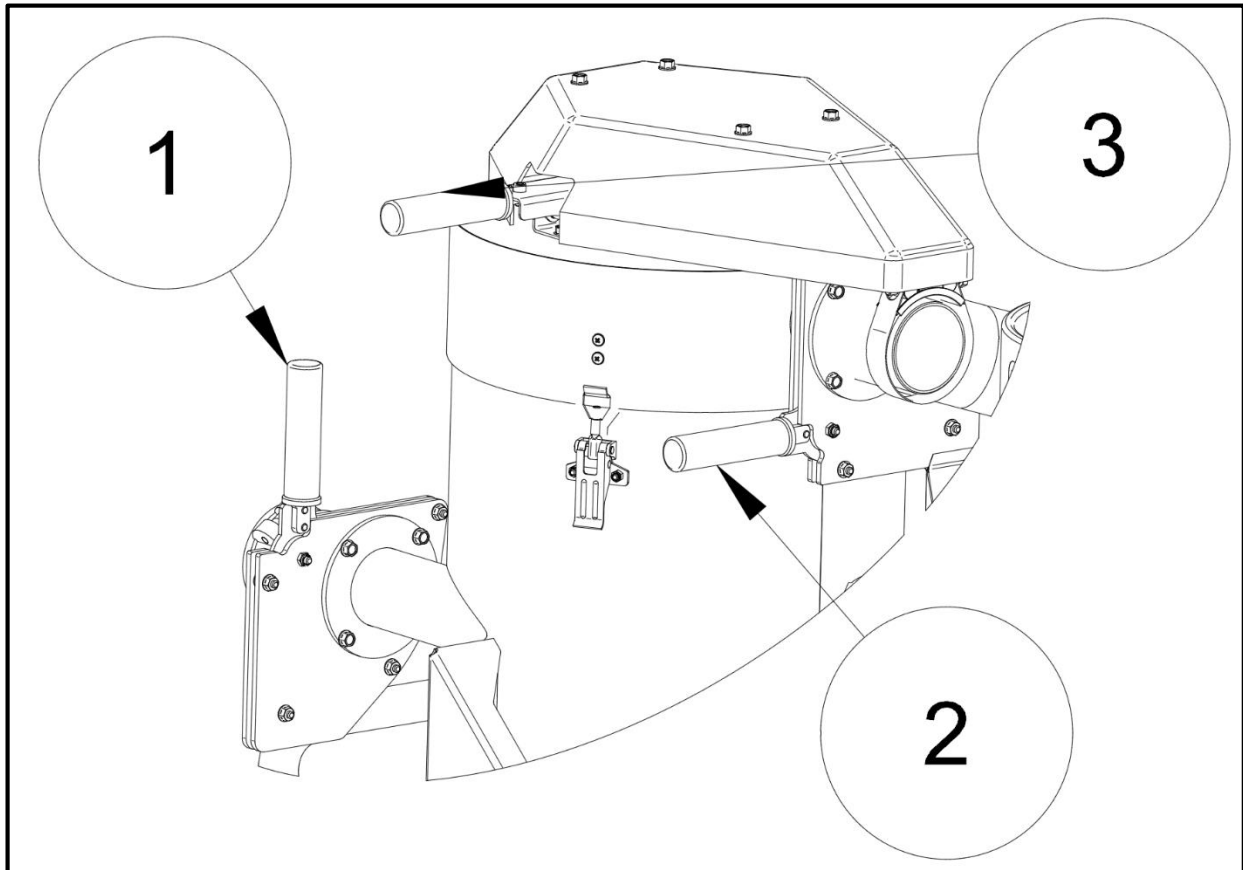

Figure 7.2

The Lavina V20E uses jet pulse manual filter cleaning. One cycle of filter cleaning takes 10 to 20 seconds, depending on the vacuum's operator. The filter must be cleaned as the vacuum gauge goes to red or if there's low suction. If the suction performance is still not improved after a cleaning cycle is applied, the filter must be replaced with new one.

In fig. 7.2 you have the vacuum's working position (valves 1 and 2 are opened and 3 stays closed). To clean the main filter, follow the steps below in the exact order:

1st. Close the valve 2. This prevents the turbine to suck air through the filter chamber, which immediately frees the dust in there, causing it to fall into the longopack plastic bag. This step is very important and should not be skipped as it drastically helps in the subsequent filter cleaning.

2nd. After discharging the filter chamber, reopen the valve 2 and close the valve 1. This creates a vacuum in the filter chamber, indicated by the pressure gauge (fig. 3.1) as it goes to red (-0.2 to -0.24 bar).

3rd. With the filter chamber under vacuum, open and close the valve 3 - **3 to 5** times to clean the filter. Allow **1-2** seconds between each valve opening to build up vacuum in the chamber again. This can also be verified via the pressure gauge. Once complete, return to the normal operating position as shown in figure 7.2.

7.3 MAIN FILTER CHANGE

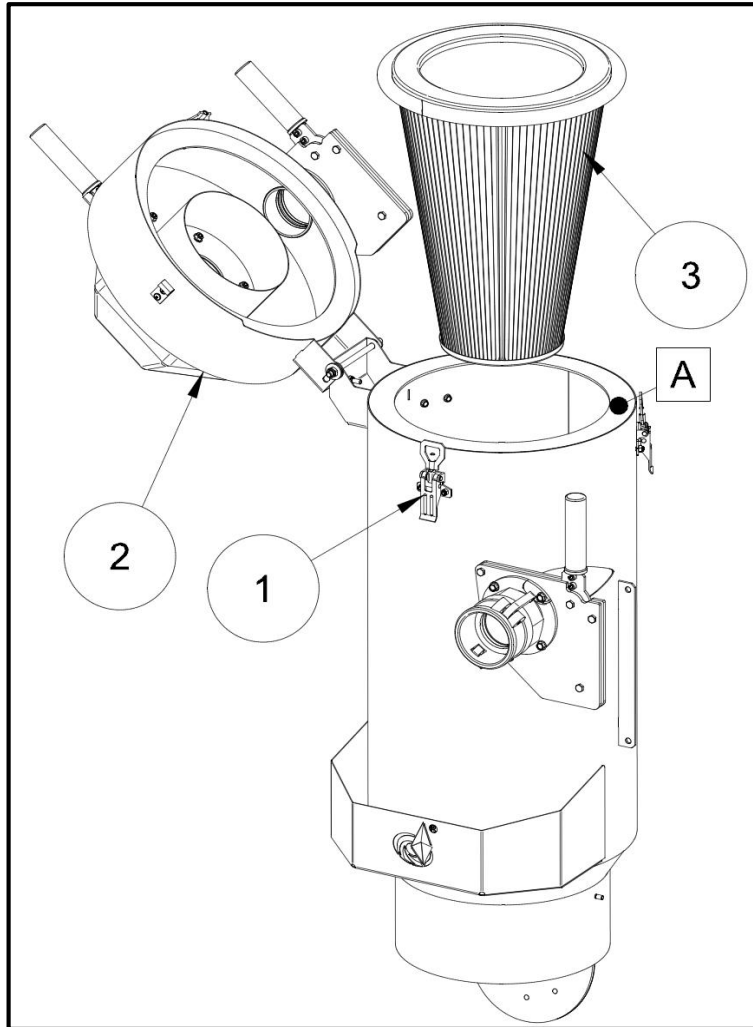

Figure 7.3

WARNING:

1. Turn off the engine and wait for the fan impeller to completely stop before opening the machine to change filters.
2. Do not touch the exhaust! It will get very hot even when running the engine for a short time.

IMPORTANT: All of the following procedures must be performed with the dust collector turned off (look at the beginning of chapter 7). Before performing any work or maintenance on the vacuum, be sure to wear the proper protective equipment. This might include clothing which covers any exposed skin, protective eyewear, a respirator, and/or protective gloves conforming to protection class FFP3.

To replace the main filter, first release the three latches (fig. 7.3 pos. 1) then open the head cover (fig. 7.3 pos. 2). Once opened, lift out the used filter (fig. 7.3 pos. 3) and place it carefully in a plastic bag. This bag must be properly disposed. Clean the area where the filter lies (fig. 7.3 A) and then insert the new filter. Only original filters may be used.

CAUTION: If you are removing the main filter in order to clean it: hitting the filter with force or using compressed air may damage the filter. It can handle being cleaned with water, but not under high pressure. Let the filter dry thoroughly before installing.

7.4 HEPA FILTER CHANGE



Figure 7.4.1



Figure 7.4.2



Figure 7.4.3



Figure 7.4.4

Figure 7.4

IMPORTANT: All of the following procedures must be performed with the dust collector turned off (look at the beginning of chapter 7). Before performing any work or maintenance on the vacuum, be sure to wear the proper protective equipment. This might include clothing which covers any exposed skin, protective eyewear, a respirator, and/or protective gloves conforming to protection class FFP3.

IMPORTANT: the used filter and debris must be disposed of using methods which fully comply with local environmental laws and regulations.

To change the HEPA filter you need to follow the four steps as it's shown in fig. 7.4.

1st Release the four latches (fig. 7.4.1).

2nd Remove the HEPA chamber's top and make sure that the sealing rings are in place (fig. 7.4.2).

3rd Lift out the HEPA filter and place it carefully in a plastic bag (fig. 7.4.3).

4th Before you insert the new HEPA filter check the sealing on the chamber's bottom (fig. 7.4.4).

After you place the new HEPA filter in the chamber do the steps in the reverse order.

7.5 LONGOPACK® BAG REPLACEMENT (CHANGING BAGS)



Figure 7.5.1



Figure 7.5.2

Figure 7.5

The Lavina® V20E has a LONGOPAC waste system for effective dust storage. This is a 20 m long plastic tube that will be divided into plastic bags using the zip ties attached to the machine.

IMPORTANT:

1. TURN OFF THE VACUUM;

- Make sure that there at least 3-4 inches of an empty bag located between the bottom of the dust container and the top of the debris/waste.
- Install 2 zip ties, or cable ties, around the plastic bag: 1 located above the top of the debris/waste, and a 2nd tie located approximately 2-3 inches higher up on the bag). Both ties must be securely tightened in order to prevent the opening of the bag and possible spillage (Fig 7.5.1).
- Using a sharp knife or scissors, cut across the entire section of plastic bag located between the 2 zip ties, or cable ties (Fig 7.5.1). Remove and dispose of the bag section containing the dust and debris.
- Pull down on the bag until the end reaches the lower bag-support plate (Fig 7.5.2).

IMPORTANT: When disposing of bags containing debris, be sure to use waste disposal containers and methods that fully comply with all environmental laws and regulations that are applicable to your specific country and location.

7.6 INSTALLING LONGOPAC® REFILL PACKS

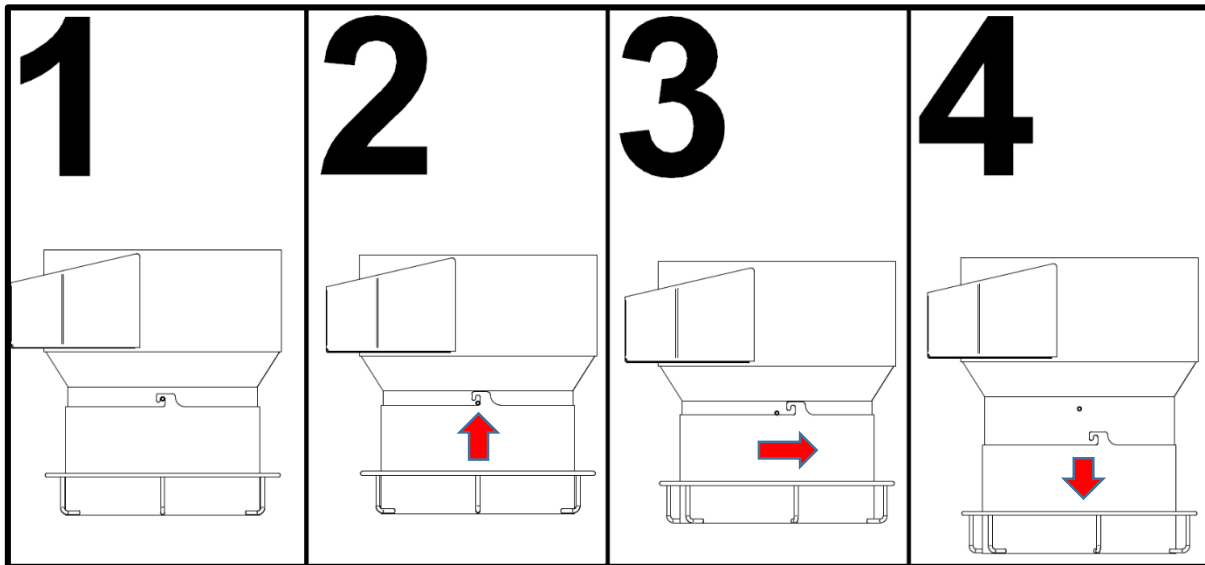

Figure 7.6

When the plastic bag cartridge has reached the end, the plastic bag refill may be installed using the following procedures:

1. At **fig. 7.6 pos. 1**, you can see the locked position of the LONGOPACK® plastic bag holder and to take it off you should:
 - Lift the holder upwards about 10-15mm to unlock it **fig. 7.6 pos.2**;
 - Rotate the holder enough that you can bring it down and take it off from the filter chamber **fig. 7.6 pos.3**;
 - Take off the holder **fig. 7.6 pos.4**;
2. As you took the holder off from the vacuum, now you can place new LONGOPACK bag refill by the following steps:



Figure 7.6.1



Figure 7.6.2

1. Place the LONGOPAC® bag refill into the support ring. Ensure that the 2 ends of the refill are directed in an upwards position. Pull the inner end of bag refill down over the inside surface of the bag support ring by making sure that the hook of the holder sticks out from the bag (Fig 7.6.1 and 7.6.2).
2. After you install the new bag, you need to attach the holder back to the filter chamber by following the steps from fig. 7.6, performing it backwards.
3. After you attach it and the zip tie has been securely installed, pull the bag down until the end reaches the lower, bag-support plate (fig. 7.5.2). The vacuum cleaner is now ready for operation.

8. MAINTENANCE AND INSPECTION

IMPORTANT: All of the following procedures must be performed with the vacuum cleaner turned off and the power cable disconnected from the power source. Before performing any work or maintenance on the vacuum cleaner, be sure to wear the proper protective equipment (clothing, eye protection, and/or gloves). In order to ensure safe and efficient operation of the vacuum cleaner, the following procedures should be performed periodically (depending on the frequency of operation):

- Remove and inspect the filters for any signs of excessive wear or damage. Replace as necessary.
- Inspect all electrical components (switches, plugs, cables, etc.) for damage or exposed wiring. Replace as necessary.
- Ensure that all screws, bolts, and nuts are properly tightened.
- Check the waste container level. Clean and empty the container when the debris reaches a maximum of 75% of its full capacity.
- Check the flexible vacuum hose and accessories for significant wear or damage. If holes are present, the vacuum cleaner's efficiency will be reduced, and debris will leak into the work environment.

8.1 LAVINA® V20E ELECTRIC CIRCUIT DIAGRAM

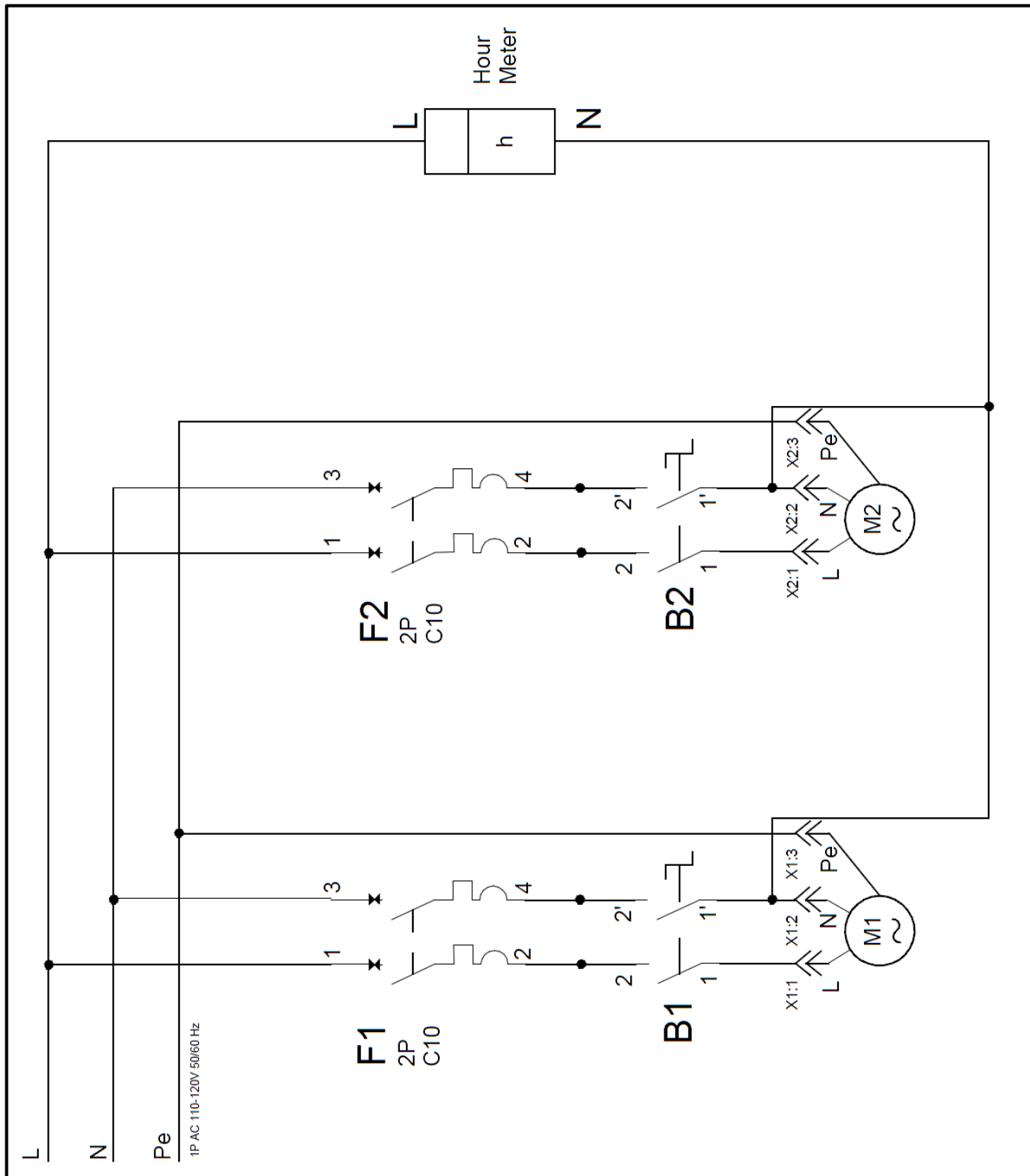

Figure 8.1

8.2 VACUUM MOTORS SERVICING

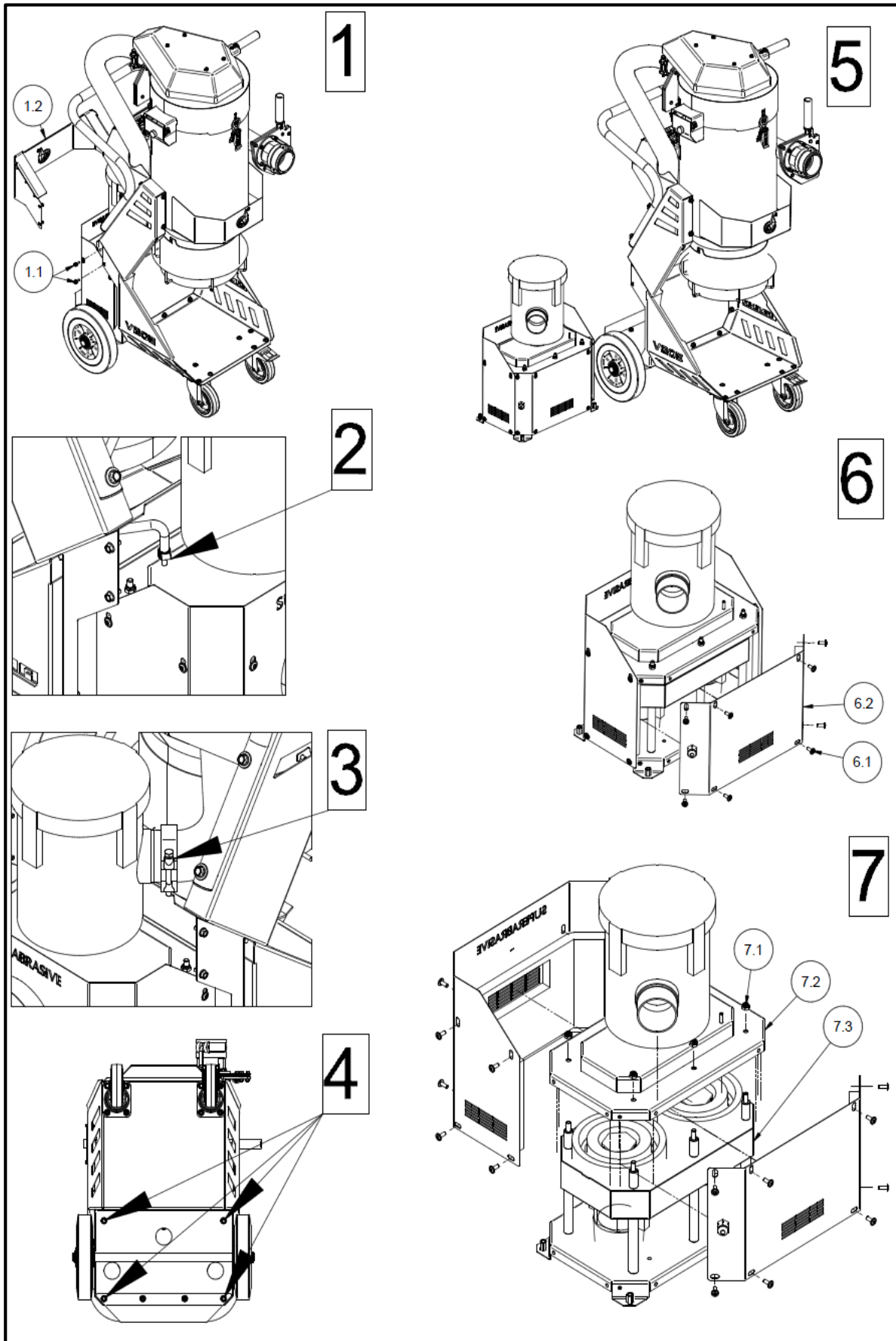

Figure 8.2

During the life of the vacuum motor, the carbon brushes inside the motor may be replaced once. These brushes are considered to be a 'wear part' and their replacement is not covered under the vacuum warranty. For additional information, please contact Superabrasive, or an authorized service facility.

To replace any of the motors, first switch off the dust collector from the power supply and then proceed to the following steps (fig. 8.2):

1. Unscrew the four bolts pos. 1.1 and remove the decorative rear cover pos. 1.2.
2. Loosen the latch and disconnect the vacuum hose from the motor chamber.
3. Loosen the latch and disconnect the intermediate hose from the HEPA filter chamber.
4. Unscrew the four bolts which are holding the motor chamber to the frame.
5. Remove the motor chamber from the vacuums frame as far as the wiring allows.
6. Open the front cover a bit so you can reach the connections behind it and disconnect the cable shoes. Move the motor chamber to a place that is more convenient for servicing.
7. As the front cover is removed, remove also the rear cover of the motor chamber. Unscrew the nuts pos. 7.1 and remove the section pos.7.2. The three motors are mounted at the section pos. 7.3. Remove it and you have full access to the motors.

8.3 FILTER CHAMBER FLAP REPLACEMENT

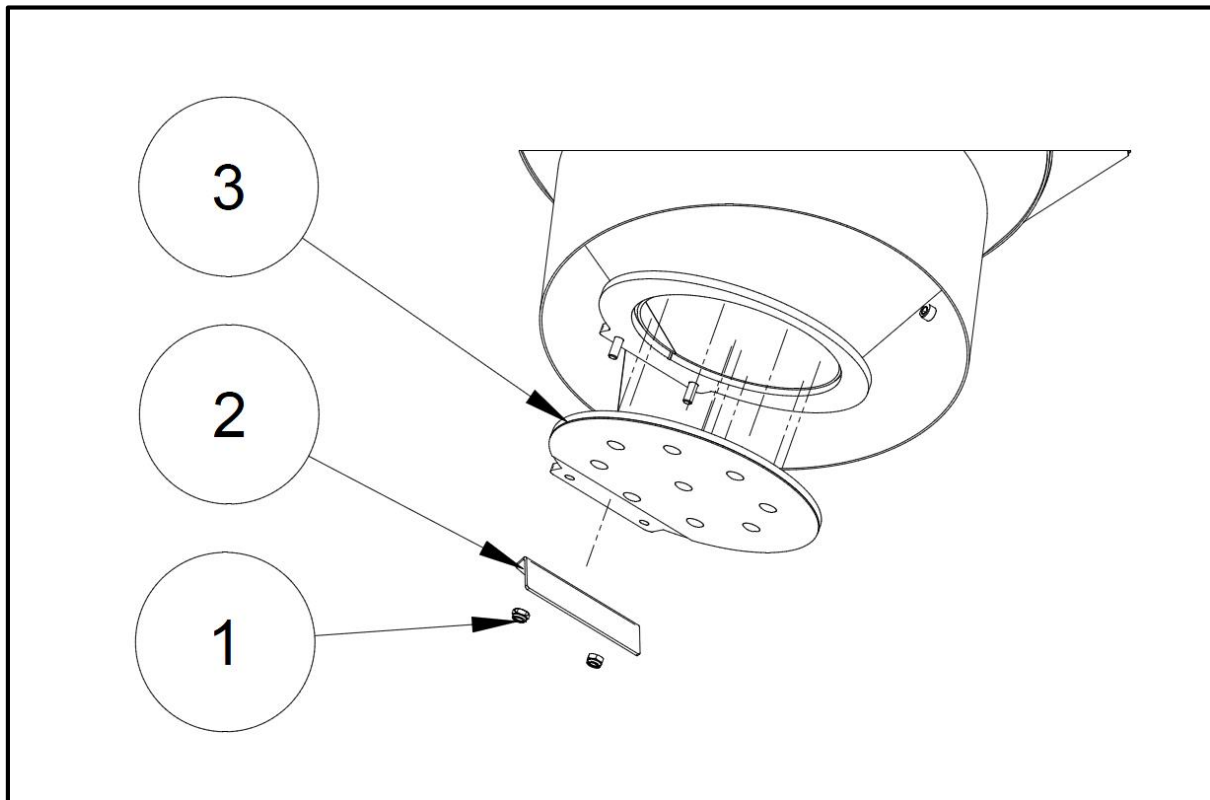

Figure 8.6

To change the flap follow those 3 steps (fig. 8.6):

- Unscrew the nuts pos.1;
- Remove the limiting plate pos.2;
- Remove the flap pos.3;











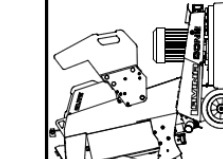





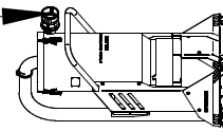

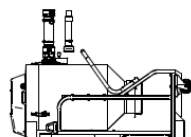
Mount the new flap and go through the steps in reversed order.

9. TROUBLESHOOTING

INDEX OF PROBLEMS AND SOLUTIONS

DUST COLLECTOR ISSUE OR SYMPTOM	POSSIBLE CAUSE	CORRECTIVE ACTION
THE DUST COLLECTOR FAILS TO START OR OPERATE.	THERE IS INSUFFICIENT POWER BEING SUPPLIED TO THE DUST COLLECTOR	CHECK THE ELECTRICAL CABLE, PLUG, AND CONNECTIONS FOR POSSIBLE DAMAGE
	THE ELECTRICAL CIRCUIT BREAKER OR GFI (GROUND FAULT INTERRUPTER) HAS TRIPPED	RESET THE CIRCUIT BREAKER OR GFI DEVICE(S).
DUST IS LEAKING FROM THE DUST COLLECTOR DURING OPERATION.	THERE ARE HOLES OR CRACKS PRESENT IN THE VACUUM HOSE OR TOOLS	CHECK THE VACUUM HOSE AND TOOLS FOR HOLES OR CRACKS. REPLACE IF NECESSARY.
	THERE ARE HOLES PRESENT IN THE FILTER	REMOVE THE FILTER(S) FROM THE VACUUM AND INSPECT FOR HOLES OR TEARS. REPLACE IF NECESSARY.
	THE VACUUM SEALS ARE MISALIGNED OR DAMAGED	MAKE SURE ALL RUBBER AND FOAM SEALS ARE INSTALLED AND ALIGNED PROPERLY. REPLACE IF ANY VISIBLE DAMAGE IS PRESENT.
THE DUST COLLECTOR DOES NOT OPERATE EFFICIENTLY, OR HAS WEAK SUCTION POWER.	THE VACUUM HOSE HAS AN OBSTRUCTION OR HOLES PRESENT	CHECK THE HOSE FOR OBSTRUCTIONS AND CLEAR THEM AS NECESSARY. REPLACE THE HOSE IF VISIBLE HOLES ARE PRESENT.
	THE VACUUM DUST CONTAINER/BAG IS FULL	FOLLOW THE PROCEDURE TO CLEAN THE MAIN FILTER, TURN OFF THE MOTORS AND CLEAN THE DUST COLLECTOR. REPLACE THE LONGOPAC® SECTION OF BAG FILLED WITH DUST AND DEBRIS.
	THE VACUUM FILTER(S) HAS EXCESSIVE BLOCKAGE	CLEAN THE FILTER. REPLACE IF NECESSARY
THE MOTOR(S) IS/ARE MAKING EXCESSIVE NOISE.	THE MOTOR(S) IS DAMAGED	REPLACE THE DAMAGED MOTOR. CONTACT SUPERABRASIVE OR AN AUTHORIZED SERVICE FACILITY

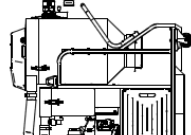
10. LAVINA® VACUUM ADAPTERS AND CONNECTIONS

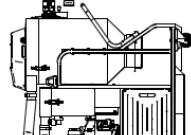
<p>Adapter needed to connect the pre-separator's hose to the vacuum.</p>  <p>V20 ELITE SERIES V20 X SERIES</p>  <p>V20 SERIES Part No: A71.00.00 Part No: A73.00.00 Part No: 30316000116</p>	<p>Adapter needed to connect the vacuum's main hose (MH) to the pre-separator.</p> <p>IMPORTANT: If you want to connect certain vac model directly to a machine, different from the vac's model group (for example vac 20 with machine 25), the info from the selection below applies.</p> <p>V20 SERIES ELITE X Part No: A71.00.00 Part No: A70.00.00</p> <p>V25 SERIES ELITE X Part No: A71.00.00 Part No: A71.00.00</p> <p>V32 SERIES ELITE X DIRECT CONNECTION DIRECT CONNECTION</p>	<p>V20 ELITE SERIES V20 X SERIES</p> <p>+ MH 2" ●</p> <p>+ MH 2.5" ●</p> <p>+ MH 3" ●</p> <p>Part No: A71.00.00 +  +  + </p> <p>Part No: A76.00.00 </p>	<p>V20 ELITE SERIES V20 X SERIES</p>  <p>V25 ELITE SERIES V25 X SERIES</p>  <p>Part No: A73.00.00 </p> <p>V32,38 ELITE SERIES V32,38 X SERIES</p> <p>Series 32 and 38 of machines and vacuums don't need any adapters as they all use 3" Camlock connections.</p>  <p>V32,38 ELITE SERIES V32,38 X SERIES</p>												
<p>V20 SERIES TO L25 ELITE ELITE X Part No: A71.00.00 Part No: A70.00.00</p> <p>V20 SERIES TO L25 X ELITE X Part No: A71.00.00 Part No: A70.00.00</p> <p>V25 SERIES TO L25 ELITE ELITE X Part No: A71.00.00 Part No: A71.00.00</p> <p>V25 SERIES TO L25 X ELITE X Part No: A71.00.00 Part No: A71.00.00</p> <p>V32 SERIES TO L25 ELITE ELITE X DIRECT CONNECTION DIRECT CONNECTION</p>	<p>V20 SERIES TO L25 ELITE ELITE X Part No: A71.00.00 Part No: A70.00.00</p> <p>V20 SERIES TO L25 X ELITE X Part No: A71.00.00 Part No: A70.00.00</p> <p>V25 SERIES TO L25 ELITE ELITE X Part No: A71.00.00 Part No: A71.00.00</p> <p>V25 SERIES TO L25 X ELITE X Part No: A71.00.00 Part No: A71.00.00</p> <p>V32 SERIES TO L25 ELITE ELITE X DIRECT CONNECTION DIRECT CONNECTION</p>	<p>+ MH 2" ●</p> <p>+ MH 2" ●</p> <p>+ MH 2.5" ●</p> <p>+ MH 2.5" ●</p> <p>+ MH 3" ●</p> <p>Part No: A71.00.00  +  + </p> <p>Part No: A71.00.00 </p> <p>Part No: A71.00.00  +  + </p>	<p>V25 ELITE SERIES V25 X SERIES</p> <p>Series 32 and 38 of machines and vacuums don't need any adapters as they all use 3" Camlock connections.</p>  <p>V32,38 ELITE SERIES V32,38 X SERIES</p>												
<p>V25 SERIES TO L32 ELITE ELITE X Part No: A71.00.00 Part No: A71.00.00</p> <p>V25 SERIES TO L32 X ELITE X Part No: A71.00.00 Part No: A71.00.00</p> <p>LAVINA VACUUM MAIN HOSE (MH) V32CX-00.40.00 V25X-00.40.00 V20X-00.40.00 V20 ELITE SERIES MAIN HOSE V20E50.00.00</p>	<p>V25 SERIES TO L32 ELITE ELITE X Part No: A71.00.00 Part No: A71.00.00</p> <p>V25 SERIES TO L32 X ELITE X Part No: A71.00.00 Part No: A71.00.00</p> <p>LAVINA VACUUM MAIN HOSE (MH) V32CX-00.40.00 V25X-00.40.00 V20X-00.40.00 V20 ELITE SERIES MAIN HOSE V20E50.00.00</p>	<p>+ MH 2.5" ●</p> <p>Part No: A73.00.00 </p>	<p>V25 ELITE SERIES V25 X SERIES</p> <p>Series 32 and 38 of machines and vacuums don't need any adapters as they all use 3" Camlock connections.</p>  <p>V32,38 ELITE SERIES V32,38 X SERIES</p>												
<p>PART DESCRIPTION TABLE</p> <table border="1"> <tr> <td>A70.00.00</td> <td>CAMLOCK ADAPTER 3inM-to-2inF</td> </tr> <tr> <td>A71.00.00</td> <td>CAMLOCK ADAPTER 3inM-to-2.5inF</td> </tr> <tr> <td>30316000116</td> <td>CAMLOCK ADAPTER 3inF-to-2inM</td> </tr> <tr> <td>A73.00.00</td> <td>CAMLOCK ADAPTER 3inF-to-2.5inM</td> </tr> <tr> <td>A76.00.00</td> <td>ADAPTER Ø50-to-2.5inF</td> </tr> <tr> <td>V25X-00.60.00</td> <td>ADAPTER 2.5inM-to-Ø50</td> </tr> </table>				A70.00.00	CAMLOCK ADAPTER 3inM-to-2inF	A71.00.00	CAMLOCK ADAPTER 3inM-to-2.5inF	30316000116	CAMLOCK ADAPTER 3inF-to-2inM	A73.00.00	CAMLOCK ADAPTER 3inF-to-2.5inM	A76.00.00	ADAPTER Ø50-to-2.5inF	V25X-00.60.00	ADAPTER 2.5inM-to-Ø50
A70.00.00	CAMLOCK ADAPTER 3inM-to-2inF														
A71.00.00	CAMLOCK ADAPTER 3inM-to-2.5inF														
30316000116	CAMLOCK ADAPTER 3inF-to-2inM														
A73.00.00	CAMLOCK ADAPTER 3inF-to-2.5inM														
A76.00.00	ADAPTER Ø50-to-2.5inF														
V25X-00.60.00	ADAPTER 2.5inM-to-Ø50														

11. SPARE PARTS

Note: There are three variations of V20E – V20E115V, V20E230V and V25EU.

11.1 GENERAL PARTS

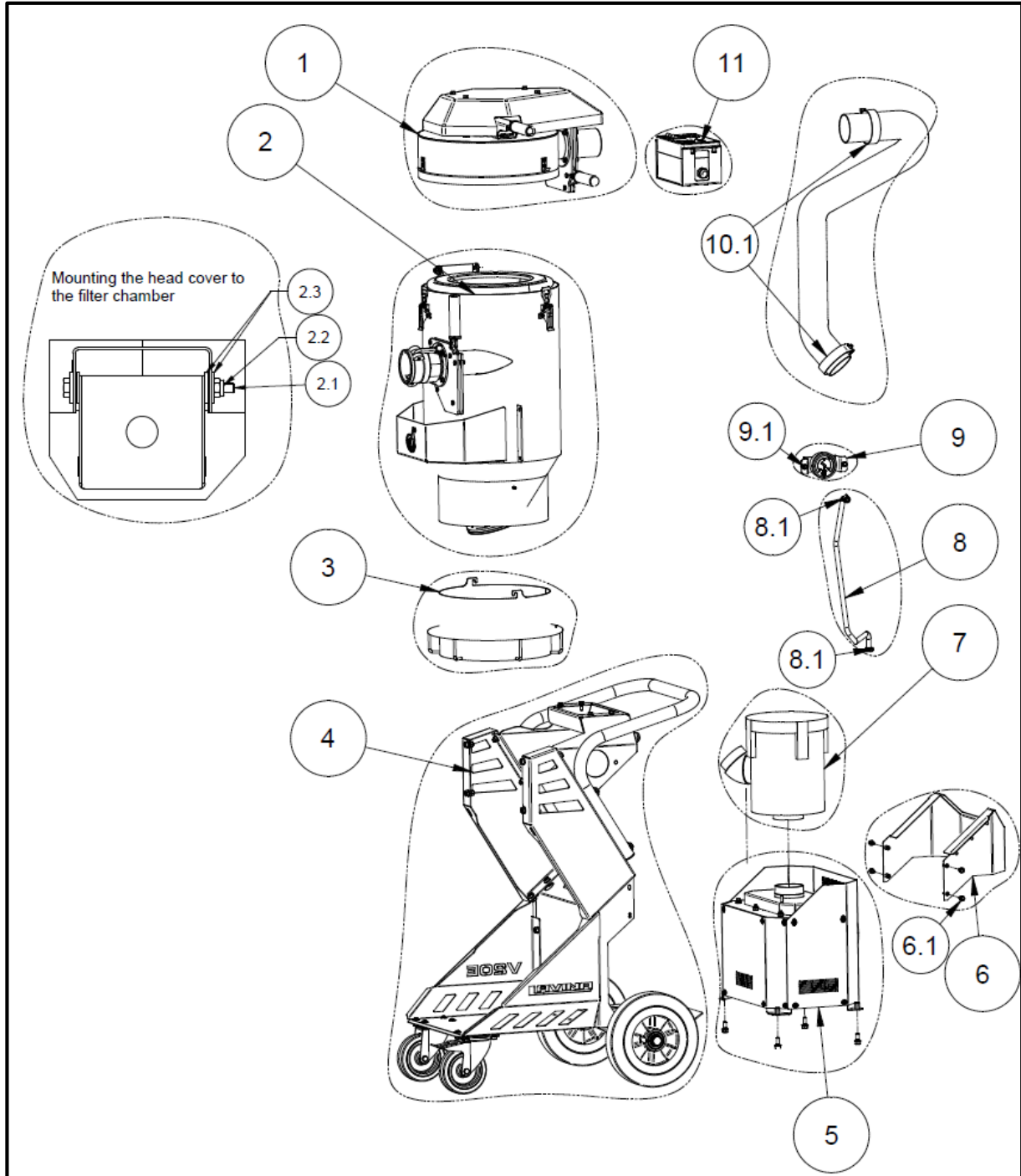

Figure 11.1

LAVINA® V20E GENERAL PARTS										
Model	No.	Item No.	Description	Pcs.	Model	No.	Item No.	Description	Pcs.	
ALL	1	V25GE30.00.00	Head cover assembly	1		7.1	30323000006	HEPA filter chamber + filter	1	
ALL	2	V20E10.00.00	Filter chamber	1		7.2	V25GE40.00.04	HEPA inlet elbow	1	
	2.1	30301210166	Bolt M8x130 DIN 931	1	ALL	8	V20E00.00.03	Pressure hose	1	
	2.2	30301240106	Nut M8 DIN 985	1		8.1	30308000419	Clamp	2	
	2.3	30301221019	Washer M8 DIN 9021	4	ALL	9	V25GE50.00.00	Vacuum gauge assembly	1	
ALL	3	VE10.00.00	Longopac® bag holder	1		9.1	30301210051	Bolt M6x16 DIN 6921	2	
ALL	4	V20E20.00.00-1	Carriage	1	ALL	10	V20E00.00.02	Intermediate hose	1	
DEPEND ON MODEL	5	V20E11540.00.00-1-K V20EU40.00.00-1-K	Power unit assembly kit	1		10.1	30308000408	Clamp	2	
V20E115V	5.1	V20E11540.00.00-1	Power unit assembly	1	DEPEND ON MODEL	11	V20E11560.00.00-K V20E23060.00.00-K V20EU60.00.00-K	Control board kit	1	
V20E230V		V20EU40.00.00-1			V20E115V		11.1	V20E11560.00.00	Control board	1
V20EU		V20EU40.00.00-1			V20E230V			V20E23060.00.00		
ALL	5.2	30301210031	Bolt M8x20 DIN 6921	4	V20EU		V20EU60.00.00			
ALL	6	V20E00.10.00	Service cover	1	ALL	11.2	30301210051	Bolt M6x16 DIN 6921	4	
	6.1	30301210051	Bolt M6x16 DIN 6921	4						
ALL	7	30323000006-K	HEPA filter chamber kit	1						

11.2 VACUUM HEAD COVER

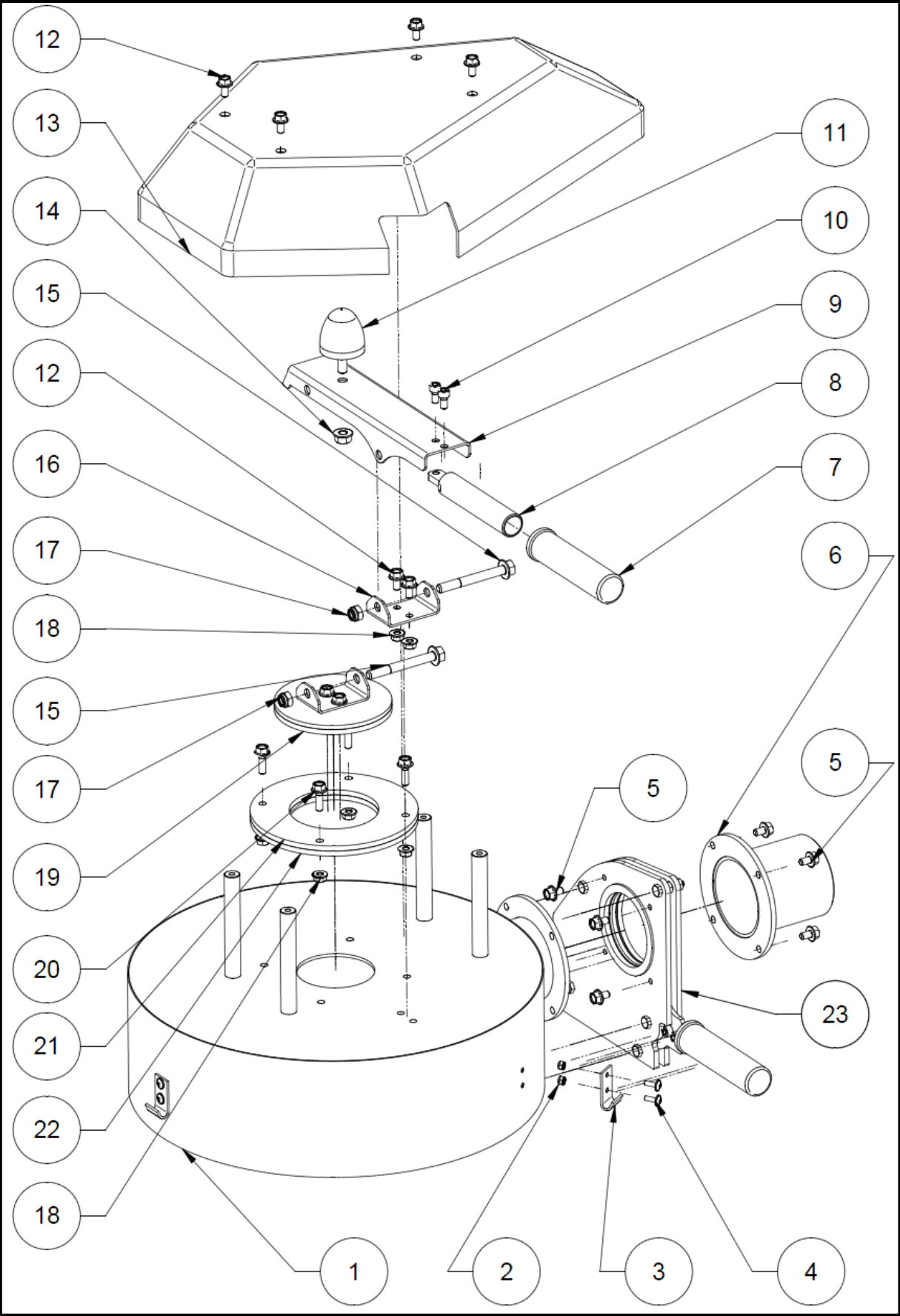

Figure 11.2

LAVINA® V20E VACUUM HEAD COVER - V25GE30.00.00							
No.	Item No.	Description	Pcs.	No.	Item No.	Description	Pcs.
1	V25GE33.00.00	Vacuum head body	1	13	V25GE30.00.02	Top cover	1
2	30301240114	Nut M4 DIN 985	6	14	30301240095	Nut M8 DIN 6923	1
3	30329000040	Clamp set	3	15	30301210069	Bolt M8x70 DIN 6921	1
4	30301230066	Screw M4x12 DIN 967	6	16	V25GE30.00.01	Bearing plate	1
5	30301210043	Bolt M6x10 DIN 6921	8	17	30301240106	Nut M8 DIN 985	2
6	V25GE31.00.00	Outlet pipe	1	18	30301240098	Nut M6 DIN 6923	10
7	30329000014	Rubber handle	1	19	V25GE34.00.00	Valve plate assembly	1
8	V20X-14.10.00	Handle body	1	20	30301210117	Bolt M6x20 DIN 6923	4
9	V25GE30.00.05	Valve beam	1	21	V25GE32.00.01	Valve base plate	1
10	30301230048	Screw M6x12 DIN 912	2	22	V25GE30.00.04	Seal	1
11	30310000005	Buffer	1	23	V25GE11.00.00	Inlet valve assembly	1
12	30301210048	Bolt M6x12 DIN 6921	6				

Note:

1. The clamp set (No 3) contains the clamp and the attaching plate and they can’t be ordered separately (fig. 10.2.1).
2. When mounting the inlet valve (pos.23) the bolts (pos. 5) must be tightened at 6 Nm.
3. Before mounting the inlet valve make sure both sealing rings are in position. The plastic side of the sealing must be in contact with the inlet valve (fig. 10.2.2).

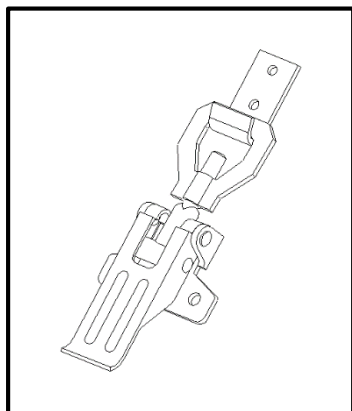

Figure 11.2.1

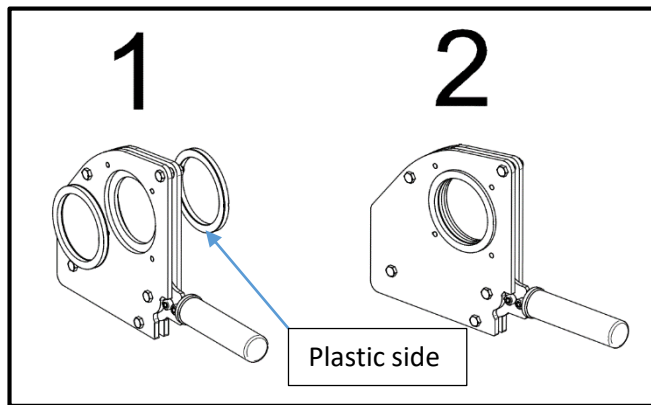

Figure 11.2.2

11.3 MAIN FILTER CHAMBER

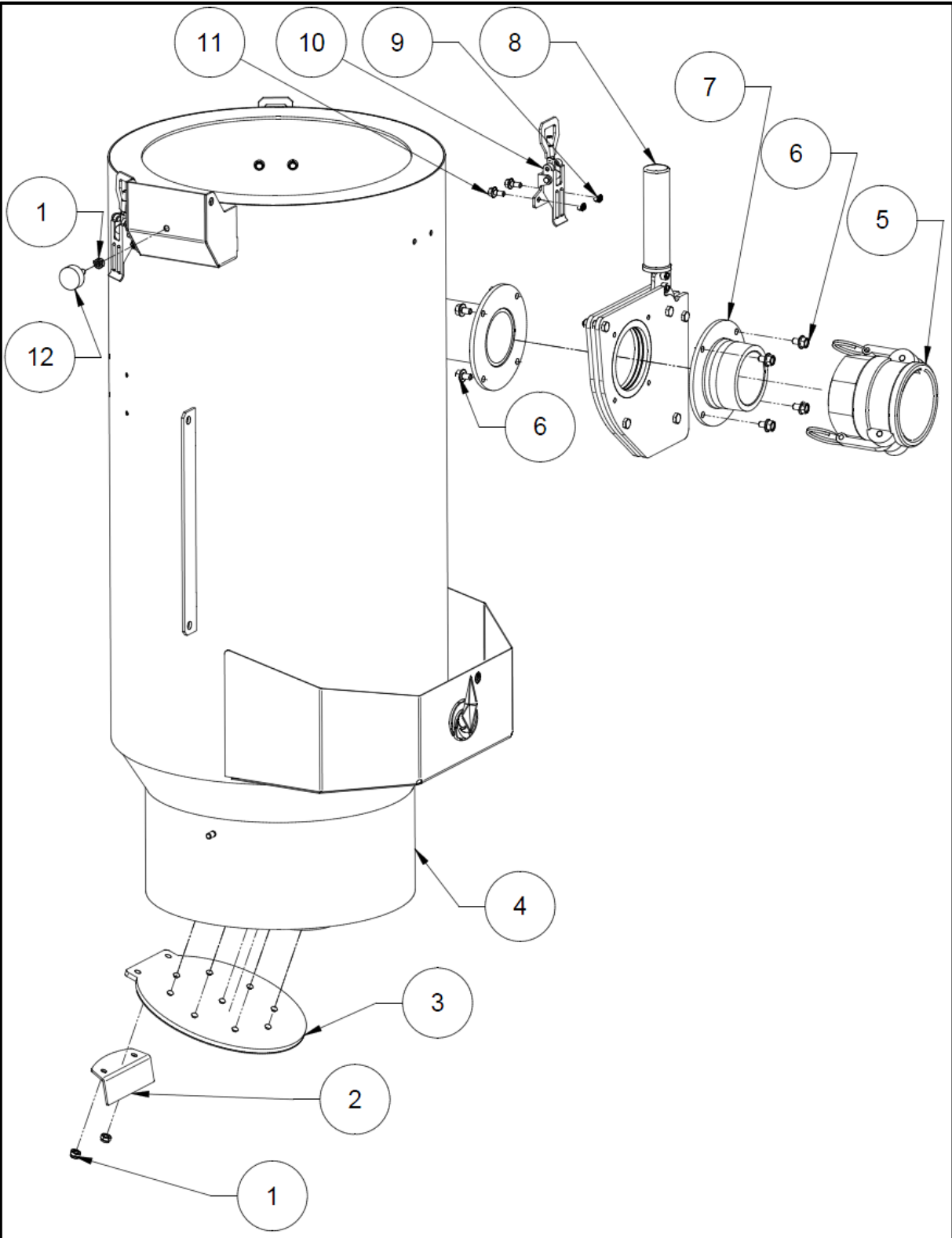

Figure 11.3

LAVINA® V20E FILTER CHAMBER - V20E10.00.00							
No.	Item No.	Description	Pcs.	No.	Item No.	Description	Pcs.
1	30301240103	Nut M6 DIN 985	3	8	V25GE11.00.00	Inlet valve assembly	1
2	V25GE10.00.02	Flap restrictive plate	1	9	30301240110	Nut M5 DIN 982	6
3	V25GE14.00.00	Flap	1	10	Look at 11.2	Clamp set	3
4	V20E13.00.00	Filter chamber body	1	11	30301210030	Bolt M5x12 DIN 6921	6
5	D250-AL	Aluminum Camlock Fitting D250-AL	1	12	30310000010	Buffer	1
6	30301210043	Bolt M6x10 DIN 6921	8	13	V25GE-F-1	Main filter	1
7	V25X-13.00.00	Camlock D200 Flange	1				

11.4 INLET VALVE

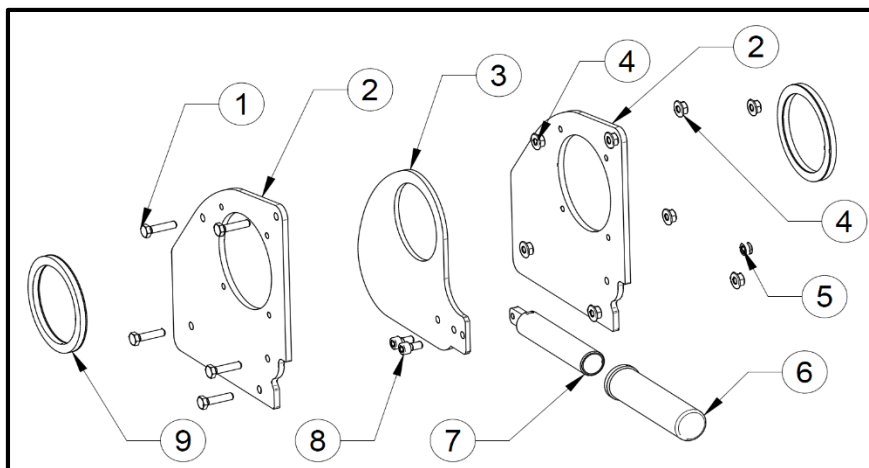

Figure 11.4

LAVINA® V20E INLET VALVE - V25GE11.00.00-K							
No.	Item No.	Description	Pcs.	No.	Item No.	Description	Pcs.
1	30301210077	Bolt M6x25 DIN 933	5	6	30329000014	Rubber handle	1
2	V25GE11.00.02	Inlet valve flange	2	7	V20X-14.10.00	Handle body	1
3	V25GE11.00.01	Inlet valve plate	1	8	30301230048	Screw M6x12 DIN 912	2
4	30301240098	Nut M6 DIN 6923	8	9	V25GE12.00.00	Sealing ring	2
5	30301240103	Nut M6 DIN 985	1	10			

11.5 CARRIAGE

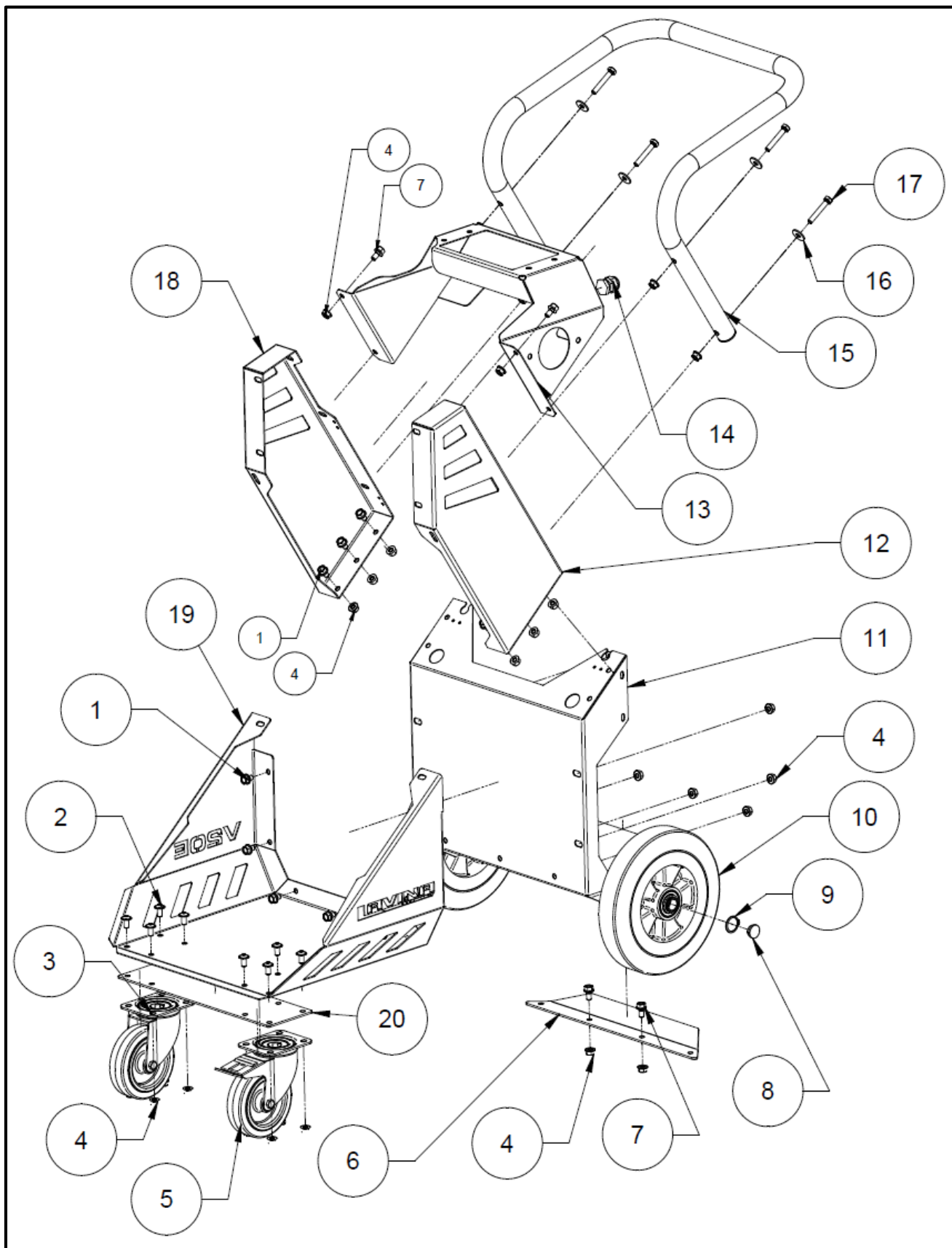

Figure 11.5

In the newer versions, the rear base plate (pos. 11) is revised. With the revised version, the foot buffer (pos. 6) is excluded from the assembly.

LAVINA® V20E CARRIAGE V20E20.00.00-1							
No.	Item No.	Description	Pcs.	No.	Item No.	Description	Pcs.
1	30301210058	Bolt M8x12 DIN 6921	13	12	V20E20.00.02	Right filter chamber holder	1
2	30301230209	Screw M8x16 ISO 7380F	8	13	V20E00.00.04	Control board base plate	1
3	30312000047	Caster wheel	1	14	30311000403	Cable gland M20x1.5	1
4	30301240095	Nut M8 DIN 6923	29	15	V20E00.20.00	Handle	1
5	30312000046	Caster locking wheel	1	16	30301221019	Washer M8 DIN 9021	4
6	V20E20.10.02	Foot Buffer	1	17	30301210106	Bolt M8x50 DIN 933	4
7	30301210072	Bolt M8x16 DIN 6921	4	18	V20E20.00.01	Left filter chamber holder	1
8	40401000112	Plastic cap	2	19	V20E20.00.03	Front base	1
9	30301250036	Circlip B25x1.2 DIN471	2	20	V20GE20.00.02	Reinforcing plate	1
10	30312000004	Wheel	2				
11	V20E20.10.00-2	Rear base	1				

11.6 POWER UNIT

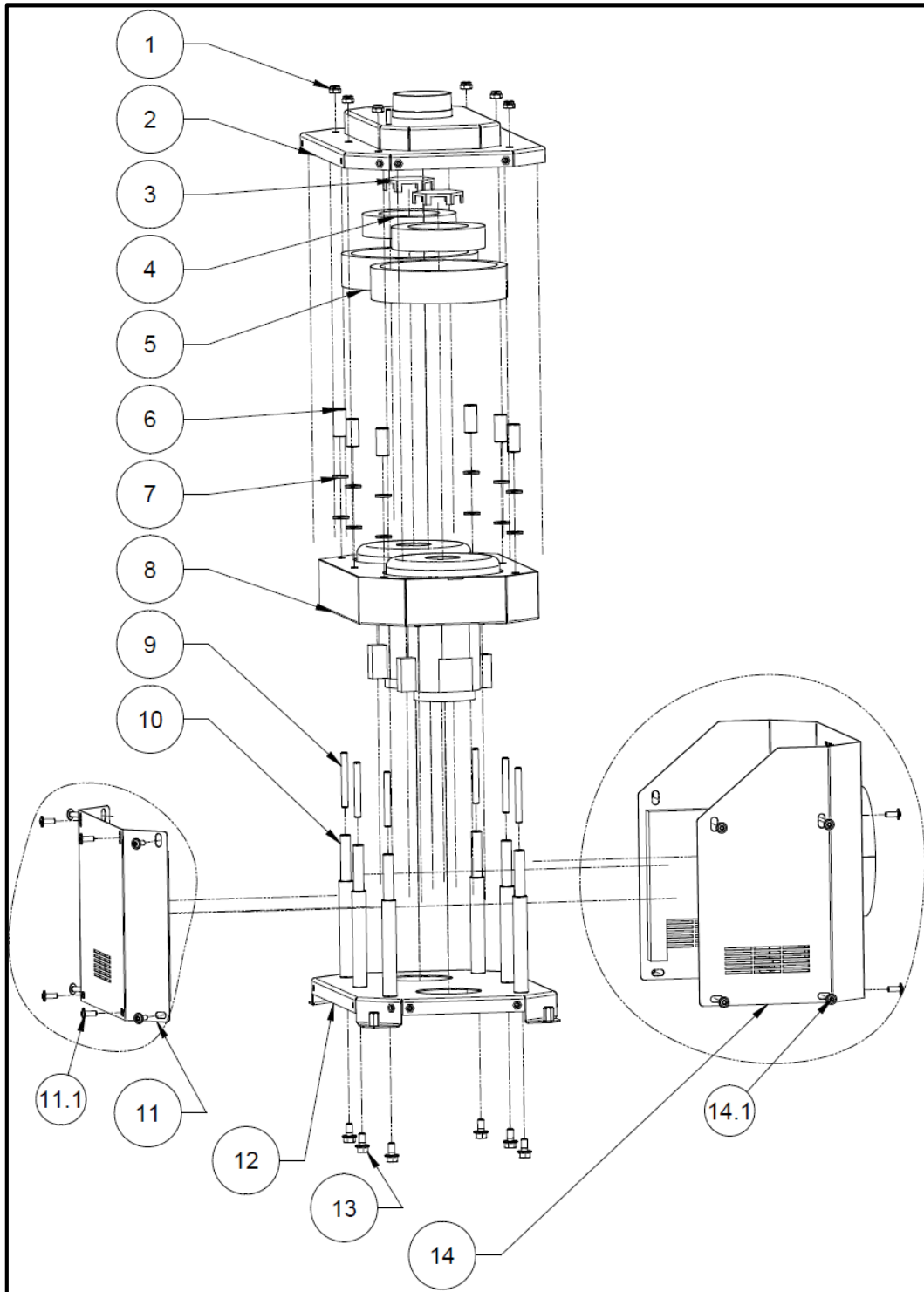

Figure 11.6

IMPORTANT: There is new version of the power unit assembly. Washers pos. 7 fig 11.6 are excluded from the assembly. Parts with pos. 9,10,13 on fig. 11.6 are replaced and are interchangeable with parts pos. 8,9,11 and 12 on fig 11.6-1.

LAVINA® V20E POWER UNIT:					
1. V20E115V - V25E11540.00.00; OLD VERSION					
2. V20E 230V – Using V20EU40.00.00;					
3. V20EU - V20EU40.00.00;					
Model	No.	Item No.	Description	Pcs.	
ALL	1	30301240106	Nut M8 DIN 985	6	
ALL	2	V20E42.00.00	Motor uniting compartment	1	
ALL	3	V25X-30.00.09	Motor valve	2	
ALL	4	V25X-30.00.08	Motor gasket	2	
ALL	5	V25E40.00.04	Major gasket	2	
ALL	6	V25E40.00.02	Distancing sleeve	6	
V20E115	7	N/A	N/A	N/A	
V20EU		30301221005	Washer M10 DIN 125A	12	
V20E115	8	V20E11543.00.00	Vac motors holder plate assembly	1	
V20EU		V20EU43.00.00	Vac motors holder plate assembly	1	
ALL	9	V25E40.00.03	Stud	6	
ALL	10	V25E40.00.01	Spacer	6	
ALL	11	V20E45.00.00	Front cover	1	
		11.1	30301230243	Screw M6x16 ISO 7380F	8
ALL	12	V20E41.00.00	Vac motors base	1	
ALL	13	30301210072	Bolt M8x16 DIN 6921	6	
ALL	14	V20E44.00.00	Rear cover	1	
		14.1	30301230243	Screw M6x16 ISO 7380F	12

LAVINA® V20E VACUUM MOTORS HOLDER PLATE ASSEMBLY				
Model	No.	Item No.	Description	Pcs.
V20E115V	1	V20E11543.20.00	Vacuum motors assembly	2
V20EU		V20EU43.20.00	Vacuum motors assembly	2
V20E115V	1.1	30313000328	Vacuum motor	1
V20EU		30313000332	Vacuum motor	1
ALL	1.2	V25E43.20.01	Vacuum motor gasket	1
V20E115V	1.3	V25X-30.00.10	Motor inlet seal	1
V20EU		V25X-30.00.10-E	Motor inlet seal	1
ALL	2	V20E43.10.00	Outlet air compartment	1
ALL	3	30301230232	Screw Ø4 8x16 DIN 7976	12

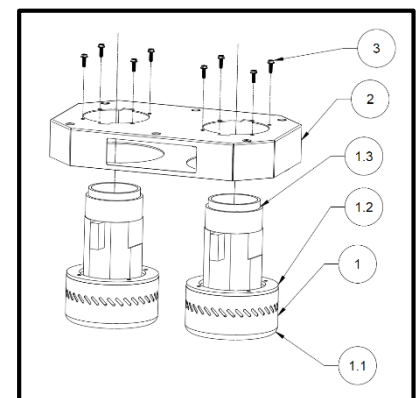

Figure 11.6.1

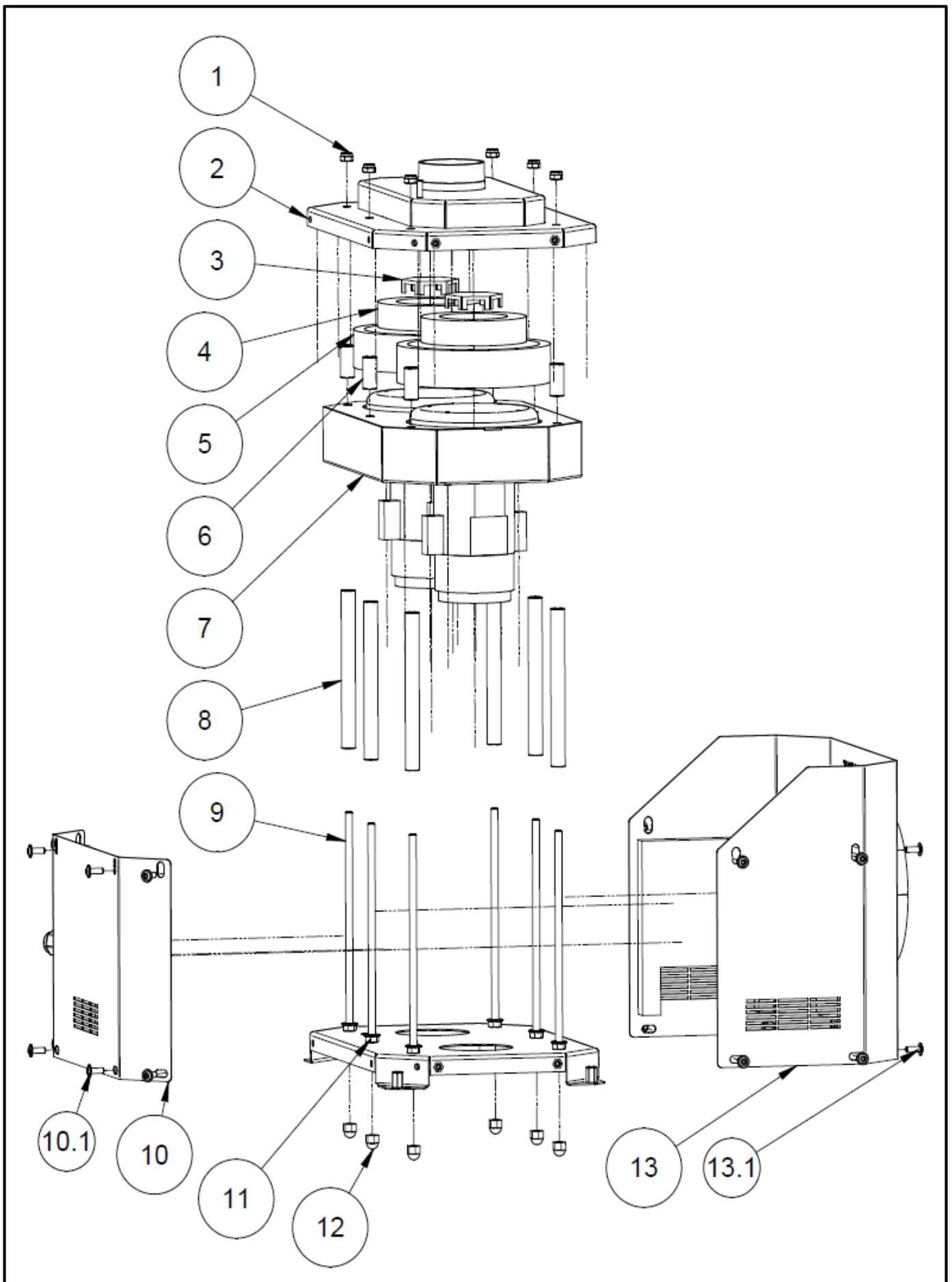

Figure 11.6-1

LAVINA® V20E POWER UNIT: CURRENT VERSION					
1. V20E115V - V25E11540.00.00-1;					
2. V20E 230V – Using V20EU40.00.00-1;					
3. V20EU - V20EU40.00.00-1;					
Model	No.		Item No.	Description	Pcs.
ALL	1		30301240106	Nut M8 DIN 985	6
ALL	2		V20E42.00.00	Motor uniting compartment	1
ALL	3		V25X-30.00.09	Motor valve	2
ALL	4		V25X-30.00.08	Motor gasket	2
ALL	5		V25E40.00.04	Major gasket	2
ALL	6		V25E40.00.02	Distancing sleeve	6
V20E115	7		V20E11543.00.00	Vac motors holder plate assembly	1
V20EU			V20EU43.00.00	Vac motors holder plate assembly	1
ALL	8		V25E40.00.01-1	Spacer	6
ALL	9		V25E40.00.03-1	Stud	6
ALL	10		V20E45.00.00	Front cover	1
		10.1	30301230243	Screw M6x16 ISO 7380F	8
ALL	11		30301240095	Nut M8 DIN 6923	6
ALL	12		30301240112	Nut	6
ALL	13		V20E44.00.00	Rear cover	1
		13.1	30301230243	Screw M6x16 ISO 7380F	12

11.7 CONTROL BOARD

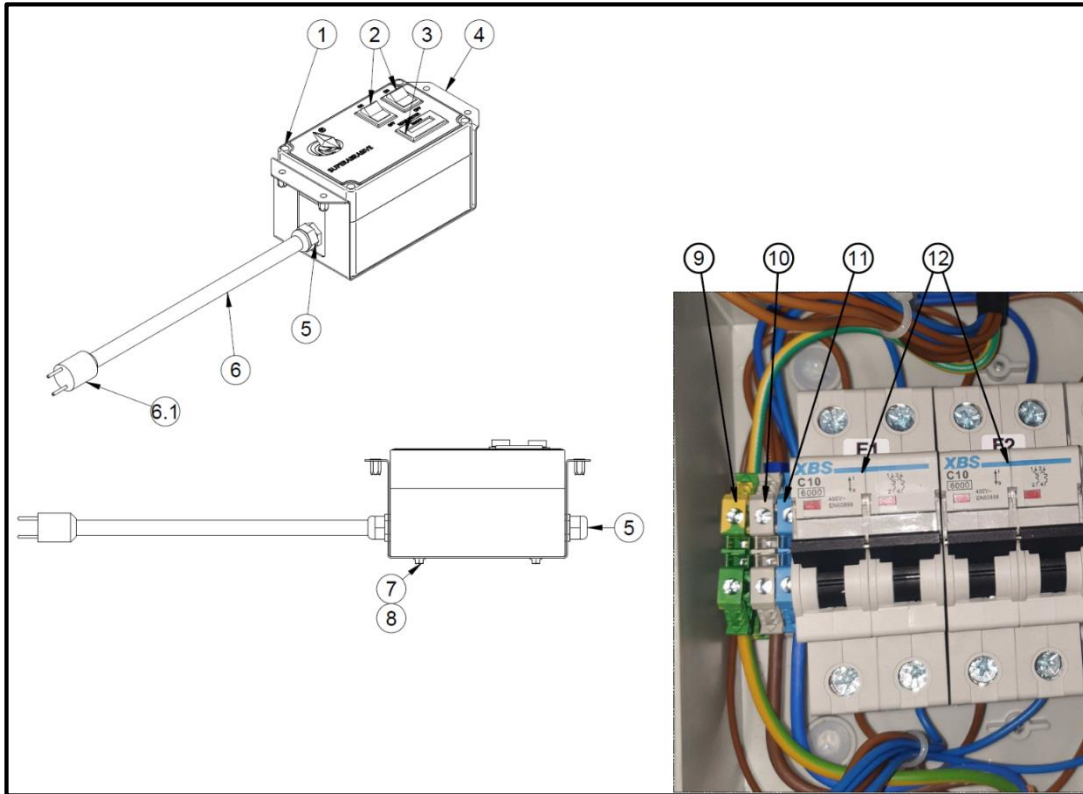

Figure 11.7

LAVINA® V20E CONTROL BOARD				
Model	No.	Item No.	Description	Pcs.
ALL	1	V20E61.00.01	Electrical compartment box	1
V20E115V	2	30311000834	ON/OFF switch	2
V20E230V		30311000833		
V20EU		30311000833		
V20E115V	3	30313000151	Hour meter	1
V20E230V		30313000155		
V20EU		30313000152		
ALL	4	V20E62.00.00	Box holder	1
ALL	5	30311000403	Cable gland	2
V20E115V	6	V20E11562.00.00	Power supply cable	1
V20E230V		V20E23062.00.00		
V20EU		V20EU62.00.00		
V20E115V	6.1	30311000060	Plug	1
V20E230V		30311000057		
V20EU		30311000145		
ALL	7	30301210030	Bolt M5x12 DIN 6921	4
ALL	8	30301240090	Nut M5 DIN 985	4
ALL	9	30311000194	Yellow-green cable terminal	1
ALL	10	30311000196	Grey cable terminal	1
ALL	11	30311000118	Blue cable terminal	1
ALL	12	30311000609	Circuit barker	2

11.8 VACUUM GAUGE ASSEMBLY

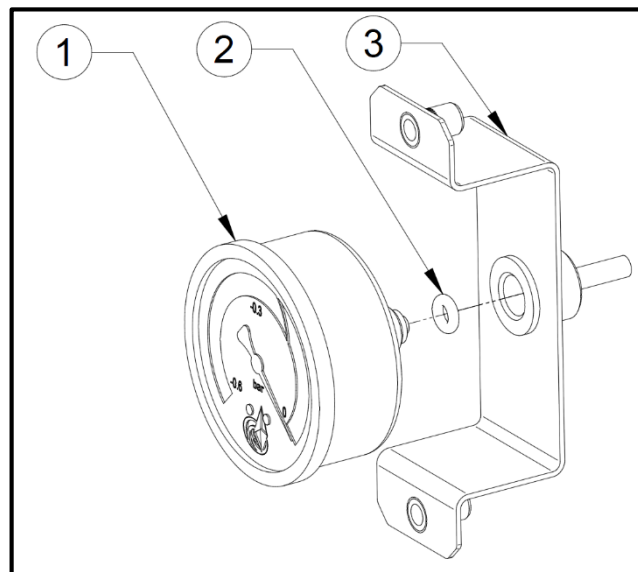

Figure 11.8

LAVINA® V25GE VACUUM GAUGE ASSEMBLY			
No.	Item No.	Description	Pcs.
1	30313000187	Vacuum gauge	1
2	30302000131	Sealing	1
3	V25GE50.10.00	Vacuum gauge base plate	1

12. ACCESSORIES



Figure 12.1



Figure 12.2

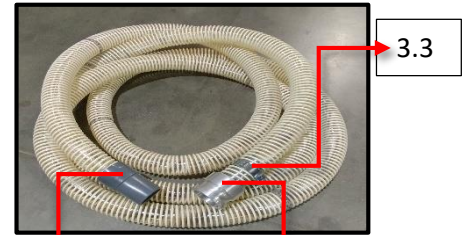

Figure 12.3



Figure 12.4



Figure 12.5



Figure 12.6

ACCESSORIES				
No.	Item No.	Description	Pcs.	Fig.
1	30310000104	Floor Brush combo 18 in L-FB-50	1	12.1
2	30316000062	Steel wand L-A-50	1	12.2
3	V20E50.00.00	Main vacuum hose with CAMLOCK and cuff	1	12.3
	3.1	30316000063	Cuff L-R-C-1	1
	3.2	V25X-00.51.00	Vacuum fitting D250	1
	3.3	30308000399	Clamp 50_70DIN3017	1
	3.4	D50x7.5	Vacuum Hose	1
4	V20E-F-2	Main filter	1	12.4
5	V25GE-FH-1	HEPA filter	1	12.5
6	V-S-L-1	Longopack bag	1	12.6
CAMLOCK ADAPTERS				
1	A70.00.00	3''M-to-2''F	1	
2	A71.00.00	3''M-to-2.5''F	1	
3	A73.00.00	3''F-to-2.5''M	1	
4	30316000116	3''F-to-2''M	1	
5	V25X-00.60.00	Adapter 2.5'' MALE CAMLOCK with Ø51 Hole with seals to fit with the steel wand, L20 ELITE SERIES and all X SERIES machines.	1	

13. DISPOSAL

If your machine after time is not usable or needs to be replaced, send the machine back to Superabrasive or a local distributor, where a professional disposal complying with the environment laws and directives is guaranteed.

14. MANUFACTURER'S CONTACTS

If you need to contact Superabrasive Inc. with technical support questions, below is the contact information.

Address: 9411 Jackson Trail Road, Hoshton GA 30548, USA

Email: info@superabrasive.us

Tel.: 706 658 1122

Fax: 706 658 0357

Website: www.superabrasive.com

15. CE-RECERTIFICATION

All LAVINA® dust collectors are designed to operate correctly in an electromagnetic atmosphere of industrial type, and are equipped with all of the mechanical and electrical safety protections in conformity with the following European CEE rules and regulations:

LAVINA® Vacuums comply with the Safety Directive for machines 2006/42/EC, the EMC Directive 2004/108/EC and the Low Voltage Directive 2006/95/EC.

They also comply with the norms in use UNI EN 13857, CEI EN 60204-1, CEI EN 61000-3-2, CEI EN 61000-3-3, CEI EN 55014.

Test results are a part of the machine's technical information and can be provided upon request. The vacuum unit machine is delivered with the CE mark exposed and is provided with a EC declaration of conformity.

16. EMISSION CONTROL WARRANTY STATEMENT

CALIFORNIA EMISSION CONTROL WARRANTY STATEMENT YOUR WARRANTY RIGHTS AND OBLIGATIONS

The California Air Resources Board and Superabrasive Inc. are pleased to explain the emissions control system warranty on your 2016 small off-road engine (SORE). In California, new SORE must be designed, built and equipped to meet the State's stringent anti-smog standards. Superabrasive Inc. must warrant the emission control system on your SORE for the period of time listed below provided there has been no abuse, neglect or improper maintenance of your SORE.

Your emission control system may include parts such as the carburetor, fuel-injection system, the ignition system, catalytic converter, fuel tanks, fuel lines, fuel caps, valves, canisters, filters, vapor hoses, clamps, connectors, and other associated emission-related components.

Where a warrantable condition exists, Superabrasive Inc. will repair your SORE at no cost to you including diagnosis, parts and labor.

MANUFACTURER'S WARRANTY COVERAGE

The emission control system is warranted for 2 years. If any emission-related part on your equipment is defective, the part will be repaired or replaced by Superabrasive Inc.

OWNER'S WARRANTY RESPONSIBILITIES

As the small off-road engine (SORE) owner, you are responsible for the performance of the required maintenance listed in your owner's manual. Superabrasive Inc. recommends that you retain all receipts covering maintenance of your SORE engine, but Superabrasive Inc. cannot deny warranty solely for the lack of receipts or for your failure to ensure the performance of all scheduled maintenance.

As the SORE owner you should however be aware that Superabrasive Inc. may deny your warranty if your SORE or its part has failed due to abuse, neglect, improper maintenance or unapproved modification.

You are responsible for presenting your utility equipment engine to a Superabrasive Inc. distribution center as soon as the problem exists. The warranty repairs should be completed within a reasonable amount of time, not to exceed 30 days. If you have any questions regarding your warranty rights and responsibilities, you should contact Superabrasive Inc. at 1-(800)-987-8403 or by e-mail at info@superabrasive.us

Superabrasive Inc

9411 Jackson trail Rd

Hoschton, GA

USA, 30548

GENERAL EMISSIONS WARRANTY COVERAGE

Superabrasive Inc. warrants to the ultimate purchaser and each subsequent purchaser that the equipment is:

Designed, built and equipped so as to conform with all applicable regulations; and

Free from defects in materials and workmanship that cause the failure of a warranted part to be identical in all material respects to that part as described in Superabrasive Inc. application for certification.

The warranty period begins on the date the equipment is delivered to an ultimate purchaser or first placed into service. The warranty period is two years.

Subject to certain conditions and exclusions as stated below, the warranty on emission-related parts is as follows:

(1) Any warranted part that is not scheduled for replacement as required maintenance in the written instructions supplied, is warranted for the warranty period stated above. If the part fails during the period of warranty coverage, the part will be repaired or replaced by Superabrasive Inc. according to subsection (4) below. Any such part repaired or replaced under warranty will be warranted for the remainder of the period.

(2) Any warranted part that is scheduled only for regular inspection in the written instructions supplied is warranted for the warranty period stated above. Any such part repaired or replaced under warranty will be warranted for the remaining warranty period.

(3) Any warranted part that is scheduled for replacement as required maintenance in the written instructions supplied is warranted for the period of time before the first scheduled replacement date for that part. If the part fails before the first scheduled replacement, the part will be repaired or replaced by Superabrasive Inc. according to subsection (4) below. Any such part repaired or replaced under warranty will be warranted for the remainder of the period prior to the first scheduled replacement point for the part.

(4) Repair or replacement of any warranted part under the warranty provisions herein must be performed at a warranty station at no charge to the owner.

(5) Notwithstanding the provisions herein, warranty services or repairs will be provided at all of our distribution centers that are franchised to service the subject engines or equipment.

(6) The SORE owner will not be charged for diagnostic labor that is directly associated with diagnosis of a defective, emission-related warranted part, provided that such diagnostic work is performed at a warranty station.

(7) Superabrasive Inc. is liable for damages to other engine or equipment components proximately caused by a failure under warranty of any warranted part.

(8) Throughout the SORE warranty period stated above, Superabrasive Inc. will maintain a supply of warranted parts sufficient to meet the expected demand for such parts.

(9) Any replacement part may be used in the performance of any warranty maintenance or repairs and must be provided without charge to the owner. Such use will not reduce the warranty obligations of Superabrasive Inc.

(10) Add-on or modified parts that are not exempted by the Air Resources Board may not be used. The use of any non-exempted add-on or modified parts by the ultimate purchaser will be grounds for disallowing a warranty claims. Superabrasive Inc. will not be liable to warrant failures of warranted parts caused by the use of a non-exempted add-on or modified part.

WARRANTED PARTS

The repair or replacement of any warranted part otherwise eligible for warranty coverage may be excluded from such warranty coverage if Superabrasive Inc. demonstrates that the SORE has been abused, neglected, or improperly maintained, and that such abuse, neglect, or improper maintenance was the direct cause of the need for repair or replacement of the part. That notwithstanding, any adjustment of a component that has a factory installed, and properly operating, adjustment limiting device is still eligible for warranty coverage. The following emission warranty parts are covered:

- (1)Catalytic converter
- (2)Fuel system: Carburetor, pressure regulator and fuel lock off
- (3)Ignition system
- (4)Intake system including pre-filter
- (5)Exhaust manifold