

LAVINA®



LAVINA® V20GE USER MANUAL



Tech Support Line: 800-987-8403 | www.superabrasive.com | info@superabrasive.us



Warranty Registration Card

Complete and submit this form within 30 days from the date of purchase. The registration is invalid without the machine serial number.

Section 1: Customer Information

Customer name

Address

City

State and Zip Code

Phone #

Email

Section 2: Machine Information

LAVINA model

Serial #

Purchase Date

Purchased From (distributor, dealer)

*Email: warranty@superabrasive.us / Fax: 706-658-0357
Superabrasive Inc., 9411 Jackson Trail Rd, Hoschton, GA 30548*

Contents

1. WARRANTY AND RETURNS.....	5
1.1 WARRANTY POLICY FOR LAVINA® V20GE	5
1.2 RETURN POLICY FOR LAVINA® VACUUMS.....	6
2. GENERAL INFORMATION.....	7
2.1 MANUFACTURER.....	7
2.2 GENERAL DESCRIPTION	7
3. MAIN COMPONENTS AND CONTROLS	8
4. TECHNICAL DATA.....	9
5. SAFETY PRECAUTIONS.....	9
5.1 RECOMMENDED USE.....	9
5.2 PROHIBITED USE.....	9
5.3 PREPARATION FOR WORK.....	10
5.4 STOP FUNCTIONS	10
5.5 SAFE USE.....	10
5.6 BEFORE YOU BEGIN	10
5.7 OPERATING THE VACUUM	10
5.8 AFTER WORK IS COMPLETED.....	10
5.9 THE WORK AREA.....	11
5.10 PERSONAL PROTECTIVE EQUIPMENT (PPE)	11
5.11 OPERATOR.....	11
5.12 PROPANE SAFETY	12
5.13 FIRE SAFETY	12
5.14 LOCAL AGENCIES AND REGULATIONS.....	12
5.15 PROPANE CYLINDERS	13
5.15.1 REFUELLING CYLINDERS	14
5.15.2 STORAGE CYLINDERS.....	14
5.15.3 TRANSPORTING CYLINDERS.....	14
6. UNPACKING, HANDLING, TRANSPORTATION AND STORAGE	15
7. OPERATING WITH THE VACUUM	16
7.1 LOCKING CASTER WHEEL.....	16
7.2 MAIN FILTER CLEANING.....	17
7.3 MAIN FILTER CHANGE	18
7.4 HEPA FILTER CHANGE.....	19
7.5 LONGOPACK® BAG REPLACEMENT (CHANGING BAGS)	21
7.6 INSTALLING LONGOPAC® REFILL PACKS.....	22

8. MAINTENANCE AND INSPECTION	23
8.1 CHECK DAILY	24
8.2 CHECK AND REPLACE AFTER THE FIRST 8 WORKING HOURS.....	24
8.3 CHECK AND REPLACE EVERY 50 WORKING HOURS.....	24
8.4 RECOMMENDED OIL CHANGE INTERVALS	25
8.5 LAVINA® V20GE ELECTRIC CIRCUIT DIAGRAM	26
8.6 FILTER CHAMBER FLAP REPLACEMENT	27
8.7 TENSIONING AND REPLACING THE BELTS	28
8.8 DISMOUNTING/MOUNTING THE ENGINE.....	29
9. TROUBLESHOOTING	30
10. LAVINA® VACUUM ADAPTERS AND CONNECTIONS.....	31
11. LAVINA® V20GE SPARE PARTS.....	32
11.1 GENERAL PARTS.....	32
11.2 VACUUM HEAD COVER.....	34
11.3 MAIN FILTER CHAMBER.....	36
11.4 INLET VALVE	37
11.5 CARRIAGE	38
11.6 VACUUM GAUGE ASSEMBLY.....	39
11.7 POWER UNIT.....	40
12. ACCESSORIES	42
13. DISPOSAL	43
14. MANUFACTURER'S CONTACTRS.....	43
15. CE-RECERTIFICATION	43
16. EMMISION CONTROL WARRANTY STATEMENT	44

1. WARRANTY AND RETURNS

1.1 WARRANTY POLICY FOR LAVINA® V20GE

If your warranty card is missing, contact your local distributor and request a warranty card, or visit us at www.superabrasive.com to download one. The customer is responsible for filling out the card and mailing it to the manufacturer's address as indicated on the card. To ensure registration and activation of warranty coverage, the warranty card must be mailed to the manufacturer within 30 days from date of purchase; failure to do so may void the warranty. Be sure to provide the manufacturer with all of the information requested, and most importantly with the distributor's name, machine serial number, and purchase date.

Superabrasive offers a guarantee on LAVINA® vacuums, covering manufacturing and material defects, for a period of 24 months from the date of purchase, as invoiced by Superabrasive. The following conditions pertain to this warranty:

- Applies only to the original owner and is not transferable.
- Vacuum must not be dismantled and tampered with in any way.
- This warranty does not cover any failures or defects caused by normal wear and tear, accidental damage, damage during transport, improper handling, repairs conducted by an unauthorized facility (without prior authorization by Superabrasive), or operation that is not in compliance with the instructions provided in this manual. Superabrasive denies all responsibility for damages or injuries, to any persons or objects, caused by improper operation of the vacuum unit.
- This warranty will become invalid in the event that equipment or accessories used on/with the vacuum unit are not supplied or approved by Superabrasive.
- Covered components proven defective will be repaired or replaced at no charge.
- This warranty does not apply to any repair of/to of proprietary parts, nor does it cover cleaning or general maintenance.
- This warranty does not apply to items with aftermarket alterations, changes, or modifications.
- This warranty is limited to repair or replacement of covered components and reasonable labor expenses.
- In the event of a warranty claim, the vacuum unit must be returned to Superabrasive, or an authorized facility, for a warranty investigation, and subsequent warranty repair or replacement.
- All warranty returns must be shipped freight prepaid.
- This warranty is in lieu of and excludes every condition of warranty not herein expressly set out and all liability for any form of consequential loss or damage is hereby expressly excluded.

The above warranty conditions may be changed only by Superabrasive. Superabrasive reserves the right to inspect and make a final decision on any machine returned under this warranty. This warranty applies to new, used, and demo machines.

Superabrasive agrees to repair or replace, free of charge, any parts which have failed due to manufacturer or material defects. Repairs must only be performed at authorized service facilities that have been approved by Superabrasive. Shipping and handling fees associated with warranty claims must be pre-paid by the customer / claimant.

In the event that a warranty investigation determines that the damage or unit failure is not attributed to manufacturer or material defects, all costs associated with the repair of the vacuum will become the direct responsibility of the claimant. If payment is not rendered for such services, Superabrasive will assume ownership of the machine and any associated parts in possession.

Superabrasive does not authorize any person or representative to make any other warranty, or to assume for us any liability in connection with the sale and operation of our products.

The manufacturer is also not liable in the event that the customer fails to submit a Warranty Certificate, fails to follow manual instructions, uses non-original spare parts, or fails to service/clean the vacuum regularly and properly

1.2 RETURN POLICY FOR LAVINA® VACUUMS

LAVINA® Vacuums may be returned, subject to the following terms:

- Vacuums may not be returned to Superabrasive Inc. for credit or repair without prior authorization. Please contact Superabrasive Inc. or your local distributor for authorization and issuance of a return authorization number. This number along with the serial number of the vacuum must be included on all packages and correspondences. Vacuums returned without prior authorization will remain property of the sender and Superabrasive Inc. will not be responsible for these.
- No vacuums will be credited after 90 days from the date of Superabrasive's invoice.
- All returns must be shipped freight prepaid. All returns may be exchanged for other equipment or parts of equal dollar value. If vacuums are not exchanged, they are subject to a fifteen percent (15%) restocking fee.

2. GENERAL INFORMATION

This owner's manual is intended for the operator of the Lavina® V20GE machine, the servicing technician as well as for anyone involved with operating or servicing the machine. We recommend that you read the instructions very carefully and follow them strictly. The manual includes information about assembling, using, handling, adjusting and maintaining your Lavina® V20GE concrete dust collector.

2.1 MANUFACTURER

Superabrasive was founded in 1987, as a manufacturer of high quality diamond tools for the stone and concrete industry. Today, Superabrasive is one of the world's leading companies in the production of diamond tools and floor grinding machinery. At Superabrasive, we strive to deliver the very best solutions to our customers, and enable them to work more efficiently.

2.2 GENERAL DESCRIPTION

Lavina® V20GE dust collector is designed for sucking and separating dry, non-combustible and non-explosion dust. Dust laden air is sucked through at high speed via the suction hose. The air is slowed down by the cyclone and coarse dust particles are separated out, partly by centrifugal force and partly by gravity. Air and finer particles then pass through filter system from the primary filter and the HEPA filter where the dust is separated. The machine is designed to clean the primary filter by impulse reverse air flow. The separated dust accumulates in the cyclone until you close the valve situated on the vacuum's hood to discharge the dust from the body or the machine is switched off. Either way the dust drops through the bottom flap into the plastic bag.

Lavina® V20GE dust collector has one hose:

- Main hose with cuff for the wand;

WARNING!

The dust collector Lavina® V20GE is manufactured and fitted for the above-mentioned applications only! Every other use may possess risks to the persons involved.

3. MAIN COMPONENTS AND CONTROLS

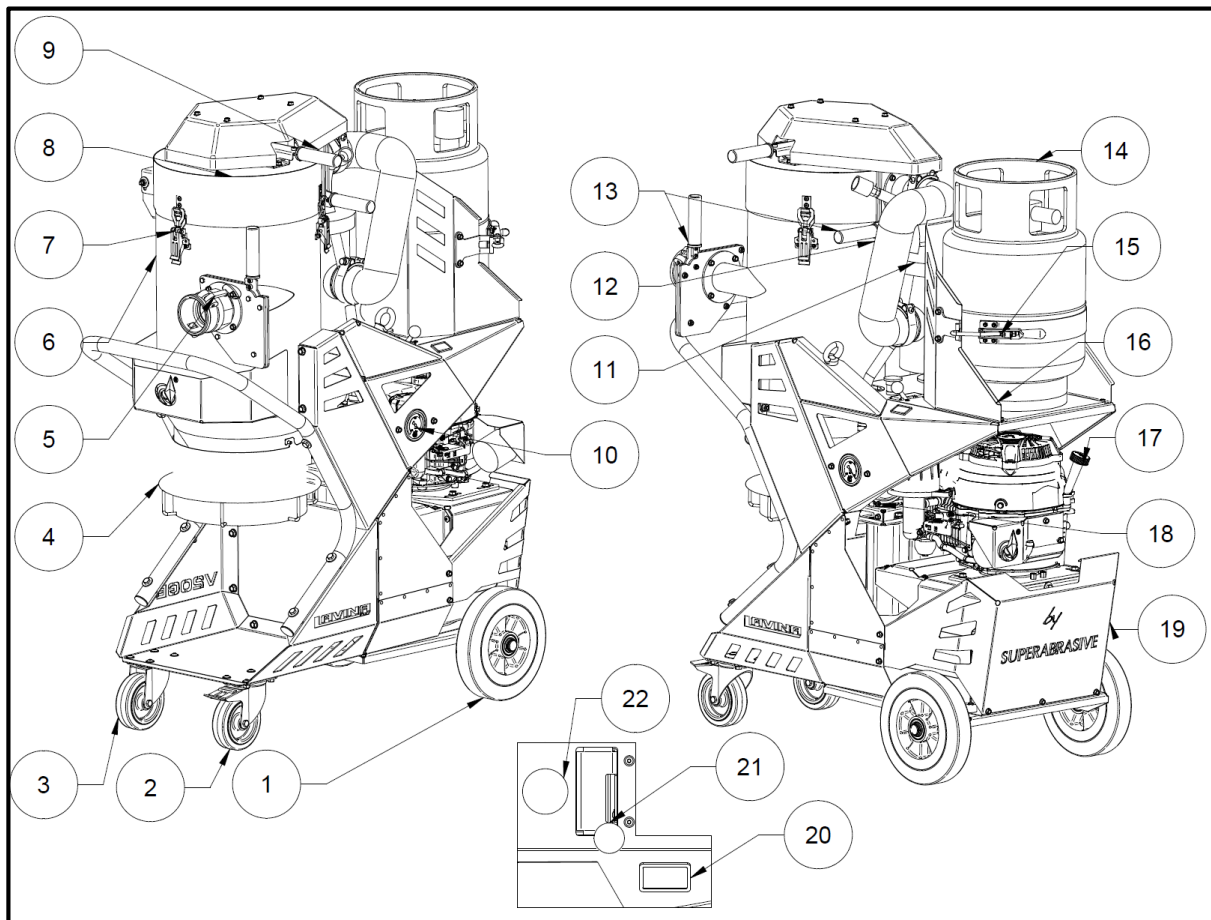

Figure 3.1

- | | |
|---|--|
| 1. Fixed wheel (2 total); | 12. Intermediate 3''' hose; |
| 2. Caster locking wheel; | 13. Valve (2 total – one for jet pulse filter cleaning and one for dust discharge); |
| 3. Caster wheel; | 14. Propane tank; |
| 4. Holder for LONCOPAC® waste system; | 15. Strap; |
| 5. Vacuum hose Camlock inlet; | 16. Propane tank holder; |
| 6. Filter chamber; | 17. Power unit assembly; |
| 7. Clamp (3 total); | 18. Regulator set; |
| 8. Vacuum head cover; | 19. Rear service cover; |
| 9. Handle for jet pulse filter cleaning system; | 20. Hour meter; |
| 10. Vacuum pressure gauge; | 21. Throttle kit; |
| 11. HEPA filter chamber; | 22. Emergency stop switch; |

Label Data - The data on the label provides the correct kW, weight and dimensions; Weight (needed for transportation purposes); production year and serial number (needed for maintenance purposes).

Customer Service - For customer assistance and technical support call your local distributor or call Superabrasive Inc. at 1-800-987-8403 or visit us at www.superabrasive.com , where you can download a copy of this manual.

4. TECHNICAL DATA

Table 4.1

LAVINA® V20GE TECHNICAL DATA		
Power/KW/hp/	kW	4.1 kW
	HP	5.5 HP
Main Filter		CONICAL FILTER
Main Filter area	m ²	3m ²
	ft ²	43 ft ²
Filter cleaning		Manual
Hepa filter area	m ²	2m ²
	ft ²	21.5 ft ²
Longopac		YES
Main hose	mmxm	50mm x 7.5m
	inxft	2in x 24ft
Airflow (max)	m ³ /h	425 m ³ /h
	CFM	250
Vacuum max	bar	0.23
	(inchH₂O)	92.4
Dimensions (L*W*H)	mm	1073x585x1396
	in	42.2x23x55
Weight	kg	140 kg
	lbs	309 lbs

5.SAFETY PRECAUTIONS

5.1 RECOMMENDED USE

The LAVINA® V20GE vacuum is designed and manufactured for use with concrete, terrazzo and natural stone floors. It is recommended for use with LAVINA® machines. This vacuum is rated for dry use only, and with a machine of appropriate size. For more information, please contact Superabrasive.

5.2 PROHIBITED USE

The vacuum MUST NOT be used:

- For applications different from those stated in this manual;

- For collecting non-suitable materials (asbestos or other toxic materials) ;
- In environments which (1) Possess the risk of explosion, (2) Possess high concentration of powders or oil substances in the air, (3) Possess the risk of fire, (4) Feature inclement conditions, (5) Possess electromagnetic radiation;

5.3 PREPARATION FOR WORK

Ensure that:

- You have secured the working area, so that no person unfamiliar with operating the vacuum can enter the area;
- The vacuum is not missing parts;
- The vacuum is in an upright, working position;
- All protection devices are working properly;

5.4 STOP FUNCTIONS

Functions for arresting of the machine include following:

- Start/Stop ignition switch;

5.5 SAFE USE

The LAVINA® V20GE is designed to eliminate all potential risks associated with its use. However, accidents may occur if unskilled or uninstructed workers fail to heed the list of potential risks below:

- Position Risks due to operator's incorrect working position;
- Tangling Risks due to wearing inappropriate working clothes;
- Training Risks due to lack of operational training;

NOTE: Machine operators should follow the instructions in the manual at all times.

RESIDUAL RISKS During normal operating and maintenance cycles, the operator is exposed to some.

5.6 BEFORE YOU BEGIN

- The working area must be clear from any debris or objects.
- A first-time operator must always read the manual and heed all safety instructions.
- Perform general daily inspections of the vacuum and inspect the vacuum before each use for any sign of damage.
- Inspect all safety devices.
- The vacuum/filters must be clean and the hose should be connected.

5.7 OPERATING THE VACUUM

When operating the LAVINA® V20GE, be sure that no one else is within close proximity to the vacuum. Never leave the vacuum unattended while working. The hose must move freely, be damage-free, and should never run beneath the vacuum or machine. Check the floor prior to beginning any work, and ensure that it's not too uneven, which can cause damage to the vacuum.

5.8 AFTER WORK IS COMPLETED

When work is complete, clean the vacuum and its surroundings sufficiently, empty all dust / debris, secure the hose, and store the vacuum in a safe and secure place.

5.9 THE WORK AREA

Ensure that the area is free of unauthorized people or vehicles, hoses, and always check the floor for debris.

5.10 PERSONAL PROTECTIVE EQUIPMENT (PPE)

When operating the machine, always wear safety shoes, ear protectors, safety gloves (especially when changing tools), and suitable clothing. All persons within the immediate working area must wear safety glasses with side shields.

5.11 OPERATOR

The operator must be aware of the vacuum's work environment, be properly trained prior to operating the equipment, and fully understand this manual. Only one operator may work with the machine at a single time. The operator must understand and interpret all the drawings and designs in manual, understand all sanitation and safety regulations pertaining to its operation, have floor grinding experience, know how to perform in an emergency situation, and have an adequate technical knowledge.

- The dust collector should only be operated in environments with a temperature between 41°F and 113°F (5°C to 45°C) and a maximum relative humidity of 70%.
- The work environment for the vacuum should be clean, well-lit, and free of combustible elements.
- The dust collector should not be operated without the proper filters installed. This could possibly result in damage to the machine, and cause harm to surrounding personnel.
- Do not open the waste container or motor head assembly while the vacuum is operating.
- Do not vacuum any flammable materials or substances such as fuels, solvents, etc. A dust collector must be specifically designed and labeled for such operation. When grinding epoxy, first ensure that the epoxy is non-toxic.
- Do not vacuum any corrosive substances unless the vacuum is specifically outfitted with containers suitable for this purpose.
- Do not vacuum any burning, smoldering, or hot materials. This could result in a possible explosion and/or damage to the vacuum components.
- If toxic or harmful substances accidentally enter the vacuum cleaner, the container and filters must be removed and cleaned immediately using the proper protective equipment and safety procedures.
- Utilize the locking caster wheel to prevent movement while work is being performed.
- When moving the dust collector, never pull on the vacuum hose. For this purpose, always use the designated handles mounted on the machine.
- For this specific dust collector, sound tests indicate that the emitted noise is level is measured at a maximum of 75 decibels (dBA), for a distance of 1 meter from the machine (and height of 1.60 meters). The vibrations emitted from the machine have been measured at a maximum value of 2.5 m/s². • CAUTION: The National Institute for Occupational Safety and Health (NIOSH) recommends that exposure to noise in the working environment be maintained below a level equivalent to 85 dBA for a period of eight hours, in order to minimize occupational, noise induced hearing loss. Any persons working in proximity of the vacuum cleaner should wear the proper hearing protection in order to prevent hearing loss. Please refer to your local laws and regulations for further information on the matter.

- When storing the vacuum, the filter should be removed and cleaned, and the waste container should be emptied of debris. Store the vacuum in temperatures between 32°F and 104°F (0°C and 40°C). Cover the vacuum in order to protect it from accumulating debris and/ or environmental elements.

5.12 PROPANE SAFETY

Propane is a flammable gas whose vapors are heavier than air. As is the case with gasoline, propane can explode if the proper cautions are not heeded. Propane is odorized with an agent having a distinct odor that is recognizable at very low concentrations. This helps in identifying leaks, even when they are small.

- Awareness and basic safety precautions are required when working with propane. As long as these precautions are followed, risk is negligible. Ignorance, however, could pose needless risk.
- The two greatest hazards with propane powered floor care machines are:
 - **Carbon Monoxide Poisoning:** This is the most frequently reported incident associated with propane powered floor care machines and is caused by excessive exhaust emissions. The symptoms are headache, dizziness and nausea. A major cause involves engines with poor preventive maintenance practices, usually those with dirty air filters and machines operated in confined areas without adequate ventilation. Another cause may be substandard, inexpensive machines with no emissions control technology and improperly set carburetion.
 - **Overfilled Fuel Cylinders:** Nearly all fire-related incidents reported result from bringing a cylinder into a building without first checking for overfill. This action is dangerous, unwise, and unnecessary.

5.13 FIRE SAFETY

- Be aware of the potential dangers of fire or explosion when using propane, and take normal fire-safety precautions.

Fire: There is a possibility of fire from LPG vapor leaking or venting from fuel cylinders or carburetion

SAFETY PRECAUTIONS, Continued equipment.

Explosion: LPG vapor concentrated or confined to a small, restricted space may explode or ignite.

Propane may experience a **BLEVE**, a boiling liquid expanding vapor explosion.

Emissions: All propane-powered floor care machines produce emissions. Most are harmless, but some are dangerous and can be fatal. Carbon monoxide (CO) poses the greatest risk, since CO can be lethal within as little as 30 minutes exposure at a concentration of 3,000 parts per million (ppm) concentration.

5.14 LOCAL AGENCIES AND REGULATIONS

- **NFPA**

Operating a propane powered floor care machine requires compliance with certain safety regulations. The National Fire Protection Agency (NFPA) Standard for Storage and Handling of LP Gas is the appropriate authority for safe propane use. A copy of this publication is available through the NFPA in Quincy, MA (1-800-334-3555).

Among its regulations, NFPA #58 requires that all personnel

employed in the handling of propane gas be trained in its proper handling and operating procedures. It also requires them to carry a written certification from their employer or training supervisor to attest to such training. Although this is directed mainly to those who fill and transport liquid propane gas, Onyx Environmental Solutions recommends that operators of propane powered floor care machines in public places be trained and certified as well.

With regard to operation of propane powered floor care equipment, even though NFPA #58 8-4.5 says “these machines shall be permitted to be used in buildings frequented by the public, including the times when such buildings are occupied by the public,” Onyx Environmental Solutions suggests usage when occupancy of a given work area is minimal.

- **CARB / EPA**

The California Air Resource Board (CARB) and Environmental Protection Agency (EPA) also set limits for propane powered engines used outdoors, but CARB/EPA approval does not signify that the engine is safe to use indoors.

- **CGA**

The Canadian Gas Association (CGA) has set a limit of 1500 ppm CO in exhaust flow.

- **OSHA**

For propane powered machines used indoors, the Occupational Health and Safety Administration (OSHA) has established a limit of 50 ppm CO for 8 hour time weighted average (TWA) in ambient air and is considering a limit of 800 ppm CO in exhaust flow.

- **DOT**

The Department of Transportation (DOT) has established regulations regarding the safety of fuel

cylinders including the ones used on propane powered floor care machines.

- **Local Agencies**

Local law enforcement agencies such as the local Fire Marshall also rely on independent testing labs such as UL and CGA before giving their approval of the use of some equipment. These labs thoroughly test equipment and submit their stamp of approval only after rigorous testing. While not being required by all law enforcement agencies, the stamp of approval by these agencies further assures the operator that he or she is working with and around safe equipment.

NOTE: In order to reduce all consequences of the above mentioned risks, we advise that machine operators will follow the instructions in the manual at all times.

5.15 PROPANE CYLINDERS

- The Propane cylinders are constructed of either aluminum or steel. We recommend aluminum because it is lighter and guards against rusting. The cylinder used on propane powered floor machines is classified as a 4E240 cylinder. Its rated capacity is 20 lbs. and this designation refers to the model of the cylinder. Actual propane capacity achieved during filling can be less than, equal to, or slightly more than 20 lbs. Use only UL, CTC/DOT listed cylinders.
- The propane cylinder used on the machine is a motor fuel cylinder as listed by the Department of Transportation. Unlike the common 20-lb propane outdoor grill cylinders (which are not legal for use on propane floor machines), the motor fuel cylinder has a number of safety systems designed into it to ensure your safety at all times.
- There are two types of 20 lb. motor fuel cylinders.

Liquid draw

Vapor draw

- The liquid draw cylinder is used on larger vehicles like forklifts. These machines have special vaporizing carburetors to allow the propane to change from a liquid to a gas before being burned in the combustion chamber.

- The vapor draw cylinder is used on small machines like the propane powered floor care machines. The vacuum generated by the engine draws up the Propane gas vapor through the fuel system. The propane powered floor care machine does not have an evaporating system and will freeze up if liquid propane is introduced to it. It is necessary that special attention be paid to ensure that neither the liquid nor the vapor draw cylinders be overfilled.

5.15.1 REFUELLING CYLINDERS

- The proper filling of propane cylinders is a subject so important that it warrants special attention. Propane cylinders should only be filled by qualified propane dealers.
- Most important, propane cylinders should be filled no more than 80% of their rated capacity. The other 20%, which is about 4" (10 cm) from the top of the cylinder, is called the vapor space or headspace. This vapor can be compressed without causing the pressure relief valve to open and vent gas to the area around the cylinder. If there is no headspace to allow for fuel expansion, the pressure relief valve will open, releasing propane gas into the atmosphere. This is a very dangerous and volatile situation as there is always the possibility that enough of the vented gas could find its way down to the floor and come in contact with a pilot light from a furnace, hot water heater, or other source of ignition.

Propane changes into a gas, is -44°F (-42° C). Exposing unprotected skin to propane gas or liquid could result in frostbite injury.

All new cylinders should be vented and purged of air per manufacturer's instructions before use. Never bleed propane cylinders indoors.

5.15.2 STORAGE CYLINDERS

- When not in use, propane cylinders always should be stored outside in an upright position in a secure, tamperproof, steel mesh storage cabinet. This cabinet may be located next to the building but with at least five feet (1.5 m) of space between the cabinet and the nearest building opening (door or window), also away from heat and direct sunlight.
- Do not install the cabinet near a stairway or street elevator as vented propane gas will seek a lower level since it is heavier than air and could find its way into the basement of the building. Do not store cylinders full or empty inside a building or inside a vehicle. Although it is unlikely that propane will vent from a stored cylinder, if it should, the vapor could come in contact with an ignition source such as a spark from a power tool or other appliance and create a flash fire.
- Do not smoke or use a device with an open flame when handling or transporting propane cylinders.

5.15.3 TRANSPORTING CYLINDERS

- When transporting cylinders to a propane dealer or to a job, make sure the cylinders are securely fastened and standing in an upright position with the service valve closed.
- A cylinder rattling around in the back of a vehicle and banging into other objects constitutes a hazard. Avoid dropping or banging cylinders against sharp objects.
- The propane cylinders are sturdily constructed but a series of hard jolts could cause damage.
- Please note that any cylinder that has been filled is always considered full, no matter how little propane gas remains in it. This is because even when all liquid has evaporated into vapor there is still some propane gas vapor left in the cylinder. Because this remaining fuel is flammable, an empty cylinder should be treated with the same careful procedures as one that is filled to the 80% level with liquid propane. The only time that a cylinder is considered empty is when it is new, before it has been filled with propane.
- When transporting a propane powered floor machine, the propane cylinder may be strapped onto the machine as long as the machine itself is firmly secured in the vehicle.
- Of course, spare cylinders should always be secured in an upright position.

6. UNPACKING, HANDLING, TRANSPORTATION AND STORAGE

When unpacking the machine, please check that the following accessories are included:

- The hose end fitting;
- Steel wand;
- Floor brush;
- Main vacuum hose with cuff to connect to the machine;

If any of the above-mentioned parts are missing, please contact your local distributor or our sales representative. Protect the environment: Please dispose of packaging materials and used machine components in an environmentally safe way according to local disposal regulations.



Figure 6.1



Figure 6.2



Figure 6.3

Attention

- During transportation, battery and propane tank must be securely fastened and completely disconnected at all times.
- Before operating the vacuum after transportation, propane tank and battery must be re-connected and correctly assembled:
 - Battery: Make sure that the wires are firmly connected to the correct terminals (black (-) & Red (+). Also confirm that the bracket that holds the battery in place is correctly assembled, so that the battery can't move during operation.
 - Propane tank: Make sure that the tank is firmly held in place by the lock and holder plate where the propane tank sits on the back of the dust collector. It should not be able to move when it's correctly assembled.

When handling and transporting the machine, never use the handles or other machine parts to lift the machine. Use always a skid or pallet for transportation, and never transport an unprotected machine in the rain or snow. Always store and transport the machine in an upright position. The machine should also always be stored in a dry, frost-proof environment.

7. OPERATING WITH THE VACUUM

IMPORTANT: Before starting the machine, check the service table for daily maintenance. Make sure that the flexible vacuum hose is securely attached to the vacuum pipe union and vacuum cleaner inlet. Check oil level. Open the service valve on the propane tank about one and a half turns (counterclockwise).

WARNING!!!

TO START THE VACUUM:

- 1) Check engine oil level.
- 2) Check engine air filter.
- 3) Open the propane tank valve one and a half turns counter clockwise.
- 4) Turn Emergency Stop clockwise to make sure it is in the up position.
- 5) Move throttle to "Start" position (farthest forward).
- 6) Press primer on the propane regulator no more than one second. (Located on the engine side of regulator)
- 7) Slowly pull the recoil starter handle until resistance is felt.
- 8) Pull recoil starter handle quickly to start engine. Repeat until engine starts.
- 9) Slowly return the recoil starter handle.
- 10) Let engine idle in "Start" position for ten to fifteen seconds to warm the engine before moving throttle to desired speed.

Before use, the operator must be trained in the handling of the dust collector and the hazardous dust.

IMPORTANT:

- TO TURN OFF VACUUM:
1. TURN THROTTLE TO THE IDLE POSITION.
 2. PRESS THE EMG STOP BUTTON.
 3. CLOSE SERVICE VALVE ON PROPANE TANK.

7.1 LOCKING CASTER WHEEL

There is one locking caster wheel located on the front of the dust collector. Locking the wheel will prevent the vacuum from moving, and possibly causing damage or injury. The wheel should be locked on uneven surfaces to prevent unexpected rolling or movement. To lock or unlock the caster wheel, follow the procedure shown below.

- To lock the caster wheel, press down on the metal tab
- To unlock the caster wheel, press backwards on the metal tab protruding from the top of the wheel assembly.



Figure 7.1

7.2 MAIN FILTER CLEANING

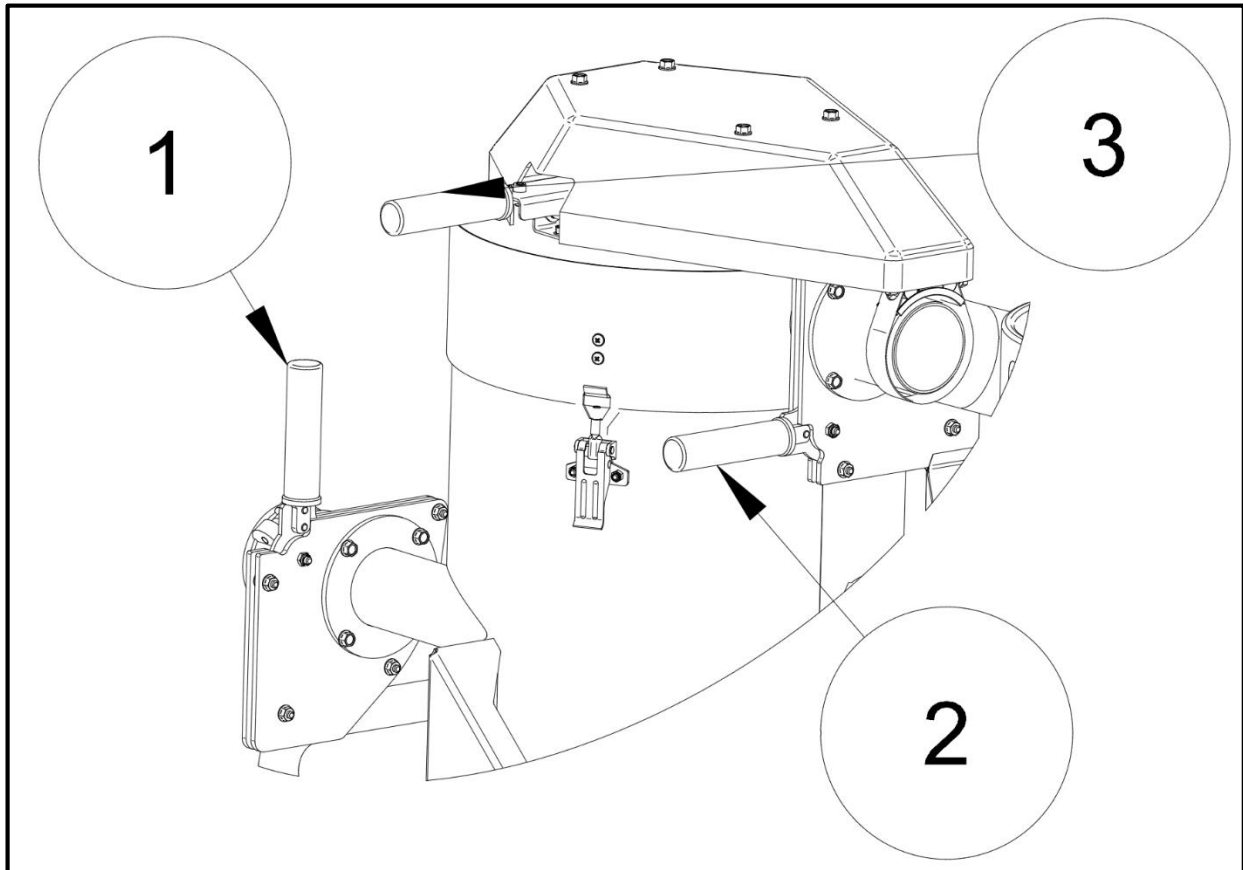

Figure 7.2

The Lavina V20GE uses jet pulse manual filter cleaning. One cycle of filter cleaning takes 10 to 20 seconds, depending on the vacuum's operator. The filter must be cleaned as the vacuum gauge goes to red or if there's low suction. If the suction performance is still not improved after a cleaning cycle is applied, the filter must be replaced with new one.

In fig. 7.2 you have the vacuum's working position (valves 1 and 2 are opened and 3 stays closed). To clean the main filter, follow the steps below in the exact order:

1st. Close the valve 2. This prevents the turbine to suck air through the filter chamber, which immediately frees the dust in there, causing it to fall into the longopack plastic bag. This step is very important and should not be skipped as it drastically helps in the subsequent filter cleaning.

2nd. After discharging the filter chamber, reopen the valve 2 and close the valve 1. This creates a vacuum in the filter chamber, indicated by the pressure gauge (fig. 3.1) as it goes to red (-0.2 to -0.24 bar).

3rd. With the filter chamber under vacuum, open and close the valve 3 - **3 to 5** times to clean the filter. Allow **1-2** seconds between each valve opening to build up vacuum in the chamber again. This can also be verified via the pressure gauge. Once complete, return to the normal operating position as shown in figure 7.2.

7.3 MAIN FILTER CHANGE

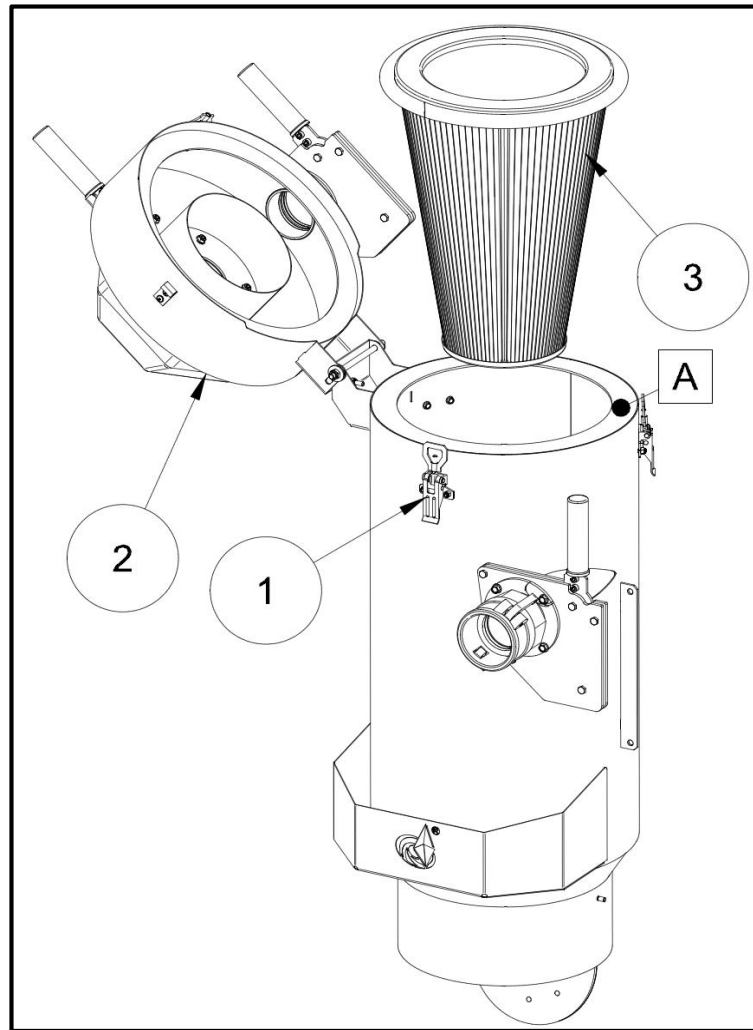

Figure 7.3

WARNING:

1. Turn off the engine and wait for the fan impeller to completely stop before opening the machine to change filters.
2. Do not touch the exhaust! It will get very hot even when running the engine for a short time.

IMPORTANT: All of the following procedures must be performed with the dust collector turned off (look at the beginning of chapter 7). Before performing any work or maintenance on the vacuum, be sure to wear the proper protective equipment. This might include clothing which covers any exposed skin, protective eyewear, a respirator, and/or protective gloves conforming to protection class FFP3.

To replace the main filter, first release the three latches (fig. 7.3 pos. 1) then open the head cover (fig. 7.3 pos. 2). Once opened, lift out the used filter (fig. 7.3 pos. 3) and place it carefully in a plastic bag. This bag must be properly disposed. Clean the area where the filter lies (fig. 7.3 A) and then insert the new filter. Only original filters may be used.

CAUTION: If you are removing the main filter in order to clean it: hitting the filter with force or using compressed air may damage the filter. It can handle being cleaned with water, but not under high pressure. Let the filter dry thoroughly before installing.

7.4 HEPA FILTER CHANGE



Figure 7.4.1



Figure 7.4.2



Figure 7.4.3



Figure 7.4.4

Figure 7.4

WARNING:

1. Turn off the engine and wait for the fan impeller to completely stop before opening the machine to change filters.
2. Do not touch the exhaust as it will get very hot even after running the engine for a short period of time.

IMPORTANT: All of the following procedures must be performed with the dust collector turned off (look at the beginning of chapter 7). Before performing any work or maintenance on the vacuum, be sure to wear the proper protective equipment. This might include clothing which covers any exposed skin, protective eyewear, a respirator, and/or protective gloves conforming to protection class FFP3.

IMPORTANT: the used filter and debris must be disposed of using methods which fully comply with local environmental laws and regulations.

To change the HEPA filter you need to follow the four steps as it's shown in fig. 7.4.

1st Release the four latches (fig. 7.4.1).

2nd Remove the HEPA chamber's top and make sure that the sealing rings are in place (fig. 7.4.2).

3rd Lift out the HEPA filter and place it carefully in a plastic bag (fig. 7.4.3).

4th Before you insert the new HEPA filter check the sealing on the chamber's bottom (fig. 7.4.4).

After you place the new HEPA filter in the chamber do the steps in the reverse order.

7.5 LONGOPACK® BAG REPLACEMENT (CHANGING BAGS)



Figure 7.5.1



Figure 7.5.2

Figure 7.5

The Lavina® V20GE has a LONGOPAC waste system for effective dust storage. This is a 20m long plastic tube that will be divided into plastic bags using the zip ties attached to the machine.

IMPORTANT:

1. TURN OFF THE VACUUM;
2. CLOSE SERVICE VALVE ON PROPANE TANK;
3. TURN THROTTLE TO THE IDLE POSITION;
4. TURN OFF KEY SWITCH;

- Make sure that there at least 3-4 inches of an empty bag located between the bottom of the dust container and the top of the debris/waste.
- Install 2 zip ties, or cable ties, around the plastic bag: 1 located above the top of the debris/waste, and a 2nd tie located approximately 2-3 inches higher up on the bag). Both ties must be securely tightened in order to prevent the opening of the bag and possible spillage (Fig 7.5.1).
- Using a sharp knife or scissors, cut across the entire section of plastic bag located between the 2 zip ties, or cable ties (Fig 7.5.1). Remove and dispose of the bag section containing the dust and debris.
- Pull down on the bag until the end reaches the lower bag-support plate (Fig 7.5.2).

IMPORTANT: When disposing of bags containing debris, be sure to use waste disposal containers and methods that fully comply with all environmental laws and regulations that are applicable to your specific country and location.

7.6 INSTALLING LONGOPAC® REFILL PACKS

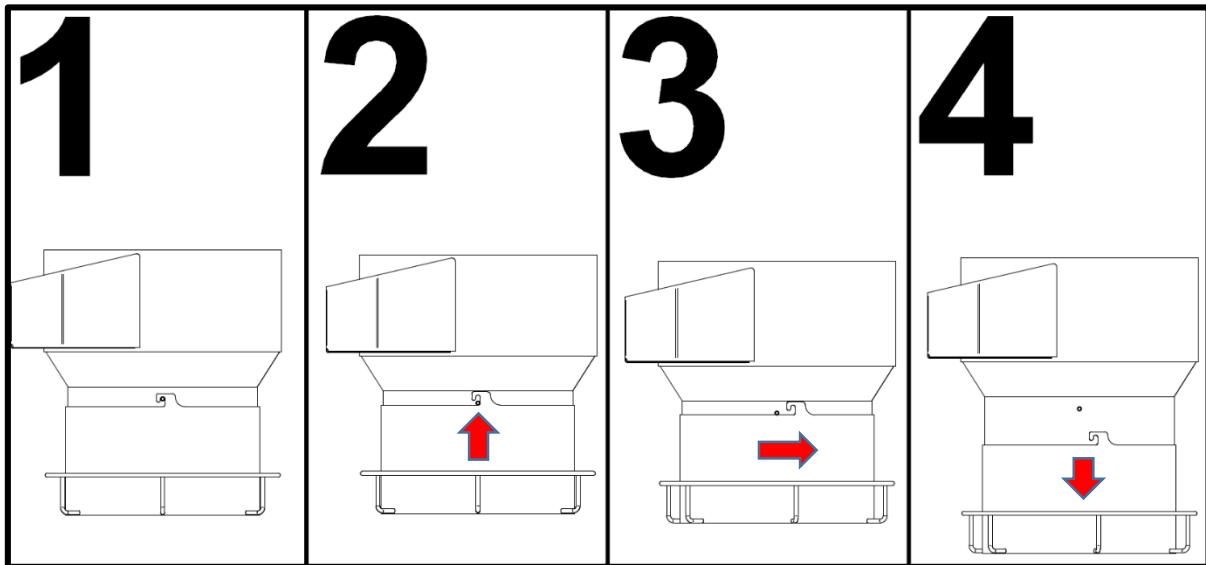

Figure 7.6

When the plastic bag cartridge has reached the end, the plastic bag refill may be installed using the following procedures:

1. At **fig. 7.6 pos. 1**, you can see the locked position of the LONGOPACK® plastic bag holder and to take it off you should:
 - Lift the holder upwards about 10-15mm to unlock it **fig. 7.6 pos.2**;
 - Rotate the holder enough that you can bring it down and take it off from the filter chamber **fig. 7.6 pos.3**;
 - Take off the holder **fig. 7.6 pos.4**;
2. As you took the holder off from the vacuum, now you can place new LONGOPACK bag refill by the following steps:



Figure 7.6.1



Figure 7.6.2

1. Place the LONGOPAC® bag refill into the support ring. Ensure that the 2 ends of the refill are directed in an upwards position. Pull the inner end of bag refill down over the inside surface of the bag support ring by making sure that the hook of the holder sticks out from the bag (Fig 7.6.1 and 7.6.2).
2. After you install the new bag, you need to attach the holder back to the filter chamber by following the steps from fig. 7.6, performing it backwards.
3. After you attach it and the zip tie has been securely installed, pull the bag down until the end reaches the lower, bag-support plate (fig. 7.5.2). The vacuum cleaner is now ready for operation.

8. MAINTENANCE AND INSPECTION

Tampering w/emission control system prohibited.

Federal law and California State law prohibits the following acts or the causing thereof:

1. The removal or rendering inoperative by any person other than for purposes of maintenance, repair, or replacement, of any device or element at design incorporated into any new engine for the purpose of emission control prior to its sale or delivery to the ultimate purchaser or while it is in use.
2. The use of the engine after such device or element of design has been removed or rendered inoperative by any person.

Among those acts presumed to constitute tampering, involve the parts/systems listed below:

- Carburetor and internal parts ;
- Spark plugs ;
- Magneto or electronic ignition system;
- Fuel filter element;
- Air cleaner elements;
- Crankcase;
- Cylinder heads;
- Breather chamber and internal parts;
- Intake pipe and tube;

WARNING!

Before cleaning and servicing the machine, you must turn the machine off and disconnect battery and propane tank.

ATTENTION!

- Wait until turbine impeller has completely stopped before starting servicing the machine.
- The exhaust will get very hot after running the engine for just a short time.
- Before moving the dust collector from the working area, the machine must be cleaned.
- All other equipment must be considered to be contaminated and be treated thereafter.
- If possible, use a special suitable room.
- Proper personnel protective equipment must be used.

- After a service, all parts that are contaminated must be taken care of properly in plastic bags, according to all regulations.
- If the dust collector has to be used for other purposes, it is extremely important that the machine is cleaned to avoid the spread of hazardous dust.

In order to ensure safe and efficient operation of the dust collector, the following procedures should be performed periodically (depending on the frequency of operation):

- Remove and inspect the filters for any signs of excessive wear or damage. Replace as necessary. (See section on "Filter Removal").
- Ensure that the gaskets on the filters are free of excessive wear or damage. Replace as necessary.
- Inspect all electrical components (switches, plugs, cables, etc.) for damage or exposed wiring. Replace as necessary.
- Ensure that all screws, bolts, and nuts are properly tightened.
- Check the waste container level. Always clean and change the bag when the debris reaches a maximum of 75% of its full capacity.
- Check the flexible vacuum hose and accessories for significant wear or damage. If holes are present, the dust collector's efficiency will be reduced, and debris will leak into the work environment.

IMPORTANT: All major repair work should be performed by Superabrasive or an authorized repair facility.

Check the turbine belt tension.

Check and clean the Propane installation.

8.1 CHECK DAILY

Check the engine oil level daily before starting the engine otherwise, shortage of the engine oil may cause serious damage. After operating the V20GE, the operator should conduct a visual inspection of the machine. Any defect should be solved immediately. Pay attention to plugs and vacuum hoses, loose bolt or screws.

8.2 CHECK AND REPLACE AFTER THE FIRST 8 WORKING HOURS

Replace the oil in the engine after the first 8 hours work, according to the instructions of the engine manufacturer.

ALWAYS USE 30HD OR 10W30 ENGINE OIL WITH ALL OF THE FOLLOWING RATINGS: SF, SG, AND CC.

8.3 CHECK AND REPLACE EVERY 50 WORKING HOURS

Change engine oil, while changing check for leakage of engine oil at the various seals. The hour meter will blink between 48-52 hours as a reminder/"Engine Oil Capacity" is 0.65L (0.69US.qt).

8.4 RECOMMENDED OIL CHANGE INTERVALS

Do not exceed the 50-hour oil change interval. Oil changes more frequent than 25 hours will give even longer engine life. In any case, always use 30HD or 10W30 engine oil with all of the following ratings: SF, SG, and CC. make sure the oil level is maintained at the "FULL" level.

Table 8.4

OPERATION	INTERVAL							
	Daily	First 8 Hrs.	Every 50 Hrs.	Every 100 Hrs.	Every 200 Hrs.	Every 300Hrs.	Every 400Hrs.	Every 500Hrs.
Check & add engine oil	X							
Check for loose or lost fasteners	X							
Check for oil leakage	X							
Inspect fuel hose and connections	X							
Clean engine dust filter	X							
Inspect throttle & wire	X							
Change engine oil		X	X					
Change engine oil filter		X		X				
Check & clean primary air filter				X				
Check secondary air filter				X				
Inspect battery and battery connections				X				
Replace engine primary air filter						X		
Replace engine pre filter								X
Inspect, clean & re-gap spark plugs, Replace if necessary								
Check & adjust valve clearance *						X		
Re-torque heads *						X		
Clean & lap valve seating surface *						X		
Check engine emissions								X
Inspect Centrifugal clutch *							X	
Check the turbine belt tension							X	

* Return machine to authorized service center for overall checkup of the Engine. For Propane safety, have the machine serviced by a Certified Technician, including emission check.

IMPORTANT: You can find more specific information about maintaining the engine by downloading it's manual at <https://www.kawasakienginesusa.com/>.

8.5 LAVINA® V20GE ELECTRIC CIRCUIT DIAGRAM

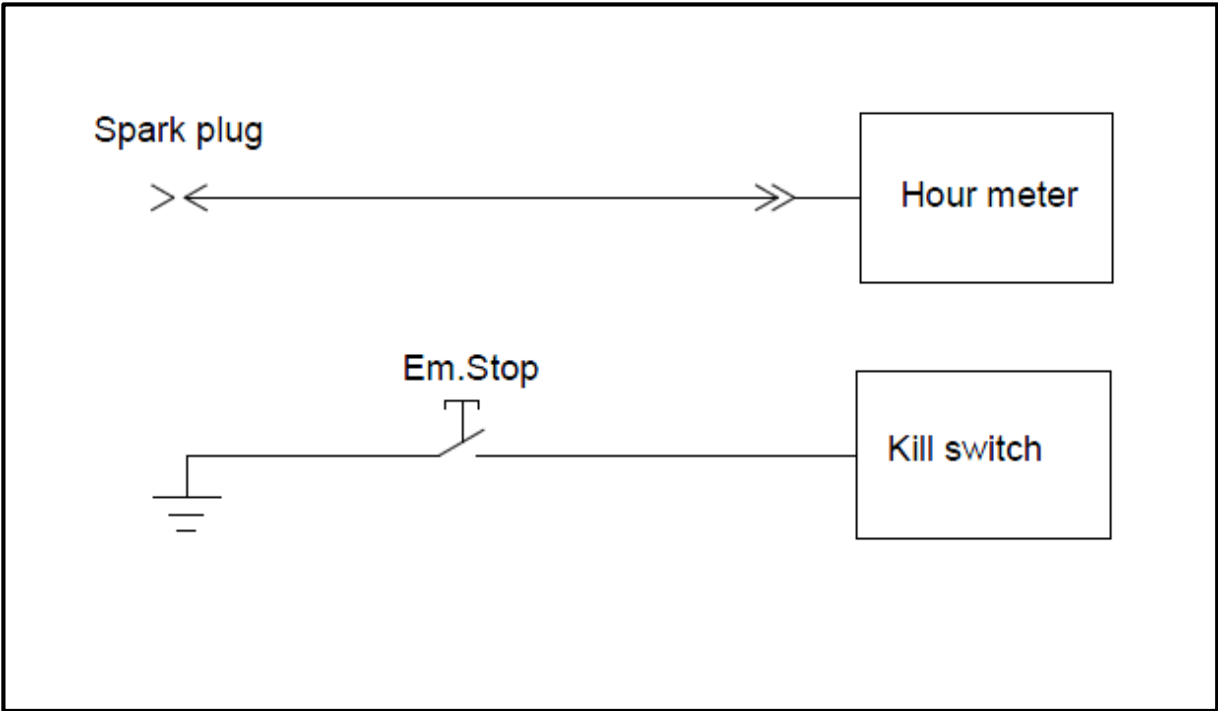

Figure 8.5

8.6 FILTER CHAMBER FLAP REPLACEMENT

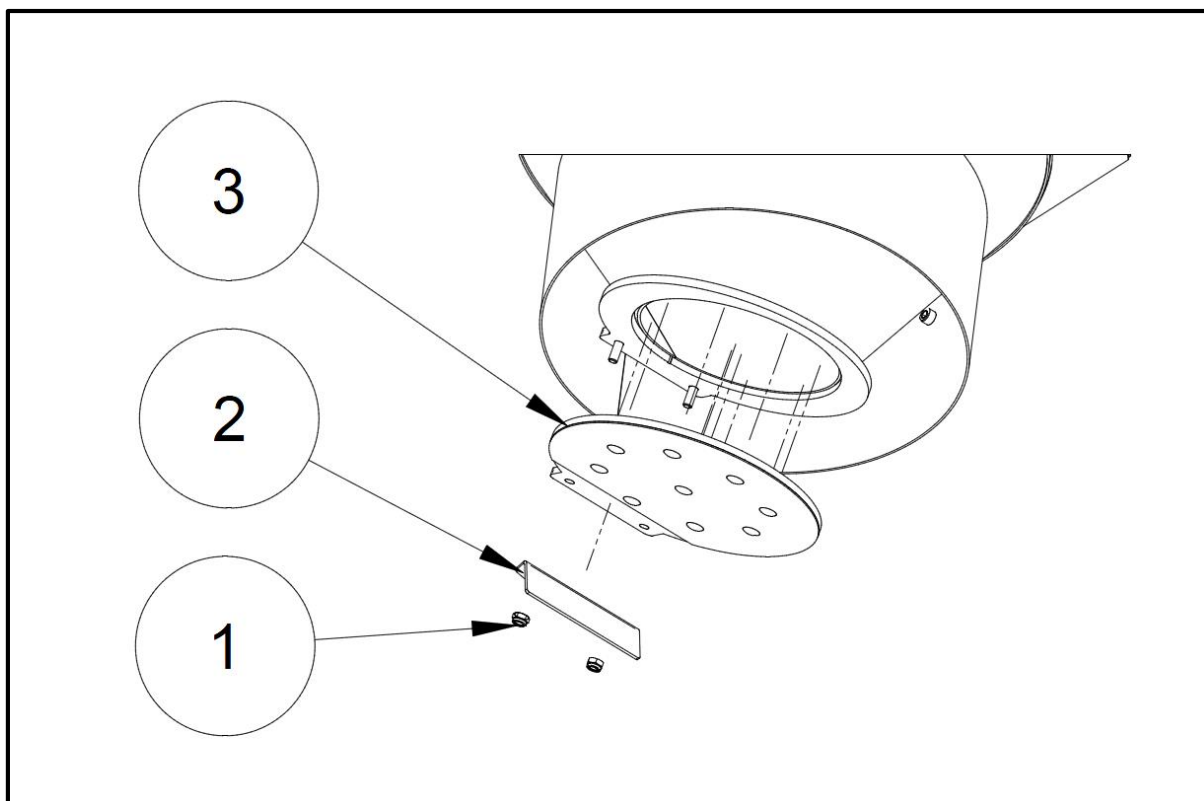

Figure 8.6

To change the flap follow those 3 steps (fig. 8.6):

- Unscrew the nuts pos.1;
- Remove the limiting plate pos.2;
- Remove the flap pos.3;

Mount the new flap and go through the steps in reversed order.

8.7 TENSIONING AND REPLACING THE BELTS

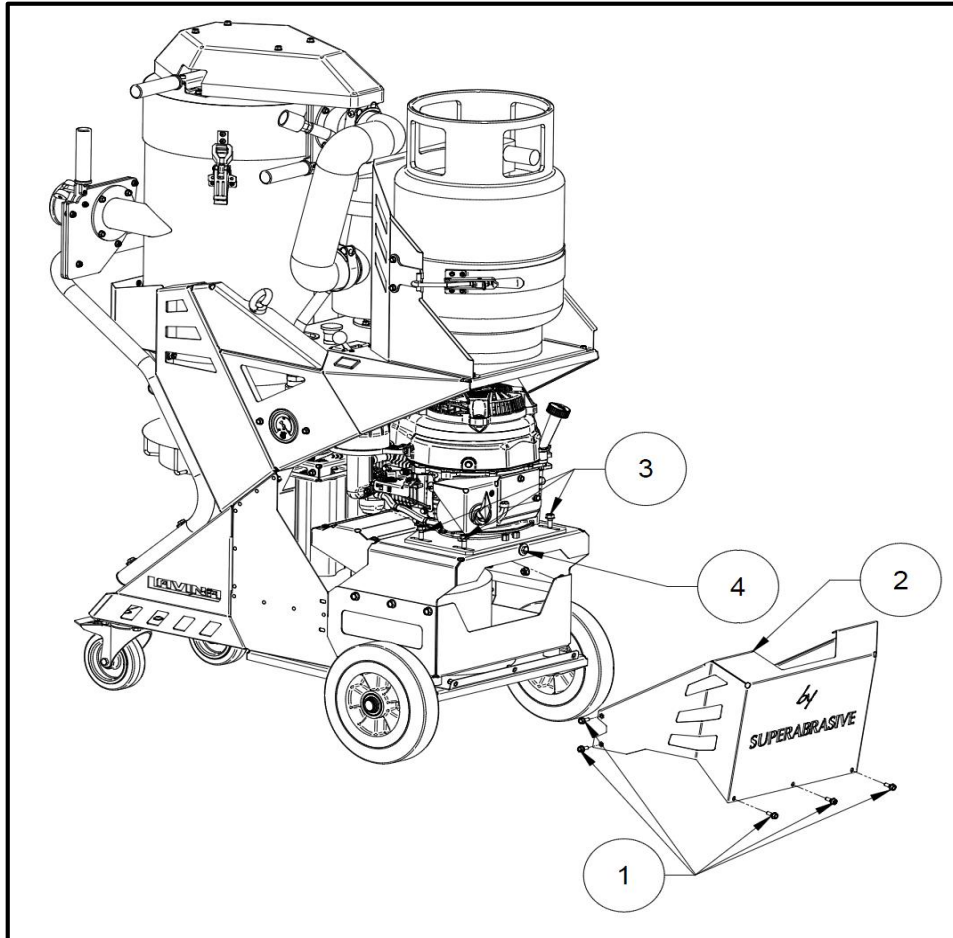

Figure 8.7

Lavina® V20GE has two belts. Changing or tensioning them happens by the following steps:

- Unscrew the seven bolts that are holding the rear protective cover of the vacuum (fig. 8.7 pos. 1);
- Remove the protective cover (fig 8.7 pos. 2);
- Loosen the four bolts that are holding the engine base plate (fig. 8.7 pos. 3);
- By screwing or unscrewing the tensioning bolt (fig. 8.7 pos. 4) the belts are being tensioned or loosened depends on your needs. By loosening the belts you can remove them and change them.

For tensioning the belts make sure you are using OPTIKRIK 1 fig. 8.7.1. If the belt is new it must be tensioned to 309N, and if it's used - 237N. After the tensioning is accomplished the four bolts fig. 8.7 pos. 3 must be screwed back to fix the engine's current position.



Figure 8.7.1

8.8 DISMOUNTING/MOUNTING THE ENGINE

To mount or dismount the engine those steps must be done:

- 1. Remove the rear protective cover, loosen the engine's base plate and take off the belts (point 8.7).**
- 2. Completely unscrew the bolts pos. 3 and 4 at fig. 8.7.**
- 3. Make sure that the hour meter, the EMG stop button and the throttle cable are disconnected from the engine.**
- 4. The engine can be dismantled.**
- 5. To mount the engine procedure is the same but in reversed order.**

9. TROUBLESHOOTING

Index of Problems and Solutions

Engine

When troubles occur, be sure to check the simple causes which at first, may seem too obvious to be considered. For example, a starting problem could be caused by fuel starvation due to an empty propane cylinder or an unopened service valve. If you do not check for this, starter burnout could result.

Some Troubles and solutions: Surging idle

To smooth out the engines' idle characteristics, adjustment is provided by an idle screw on the lower left side of the carburetor as viewed from the operator's position. The screw is bright steel and 1/4" in diameter with a Phillips head on it. Rotating the screw clockwise will increase the idle speed and this should cure the "surging idle". If it does not, call our customer service.











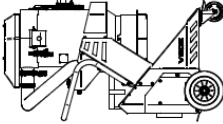



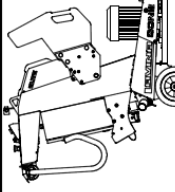
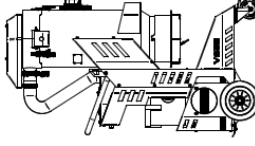















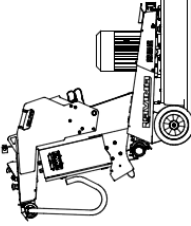
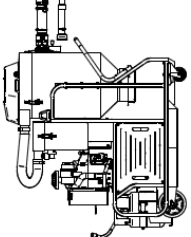





Engine starts and idles, but will quit as the throttle is advanced:

It is possible that the propane tank's service valve is faulty. To check for this, close the valve completely and then reopen very slowly while you listen for a "click" when the gas begins to travel through the valve. If you hear this very slight noise, the valve is only partially opening. This allows enough gas through to start and idle the engine, but not enough for full throttle operation. As the throttle is increased, allowing more air to enter the intake, the engine will quit from fuel starvation. Call your dealer or the factory for instructions on where to have the service valve replaced. Meanwhile, to get by, you can continue to open the service valve until you do not hear a "click" and then the engine will run normally. If it does not, call your customer service.

Starter barely turns the engine over or the solenoid just clicks:

The battery is likely low in charge. This can be remedied by recharging the battery using a 12 Volt battery charger at 4.12 amperes. The battery is located under the frame, next to the turbine. The positive post is the one with the RED cable attached to it. Follow the instructions that came with the battery charger. REMINDER: this will continue to happen unless your engine is run for sufficient time between starts to recharge the battery.

10. LAVINA® VACUUM ADAPTERS AND CONNECTIONS

<p>Adapter needed to connect the pre-separator's hose to the vacuum.</p>  <p>V20 SERIES ELITE Part No: A73.00.00 X Part No: 30316000116</p>  <p>V20 ELITE SERIES V20 X SERIES</p>	<p>Adapter needed to connect the vacuum's main hose (MH) to the pre-separator.</p> <p>V20 SERIES ELITE Part No: A71.00.00 X Part No: A70.00.00</p> <p>V25 SERIES ELITE Part No: A71.00.00 X Part No: A71.00.00</p> <p>V32 SERIES ELITE DIRECT CONNECTION X DIRECT CONNECTION</p>	<p>IMPORTANT: If you want to connect certain vac model directly to a machine, different from the vac's model group (for example vac 20 with machine 25), the info from the selection below applies.</p> <p>+ MH 2" + MH 2.5" + MH 3"</p> <p>V25X-00.60.00 (INCLUDED IN V25 SERIES) V25X-00.60.00 +  Part No A71.00.00 +  V25X-00.60.00</p>	 <p>L20 ELITE SERIES L20 X SERIES</p>											
 <p>V25 ELITE SERIES V25 X SERIES</p> <p>Part No A73.00.00 </p>	<p>V20 SERIES TO L25 ELITE ELITE Part No: A71.00.00 X Part No: A70.00.00</p> <p>V20 SERIES TO L25 X ELITE Part No: A71.00.00 X Part No: A70.00.00</p> <p>V25 SERIES TO L25 ELITE ELITE Part No: A71.00.00 X Part No: A71.00.00</p> <p>V25 SERIES TO L25 X ELITE Part No: A71.00.00 X Part No: A71.00.00</p> <p>V32 SERIES TO L25 ELITE ELITE DIRECT CONNECTION X DIRECT CONNECTION</p> <p>V32 SERIES TO L25 X ELITE DIRECT CONNECTION X DIRECT CONNECTION</p>	<p>+ MH 2" + MH 2.5" + MH 2.5" + MH 3"</p> <p>Part No A76.00.00  Part No A71.00.00  Part No A71.00.00  Part No A71.00.00  Part No A71.00.00  Part No A71.00.00  Part No A71.00.00  Part No A71.00.00  Part No A71.00.00  Part No A71.00.00  Part No A71.00.00  Part No A71.00.00  Part No A71.00.00  Part No A71.00.00  Part No A71.00.00 </p>	 <p>L25,30 ELITE SERIES L25,30 X SERIES</p>											
 <p>V32,38 ELITE SERIES V32,38 X SERIES</p> <p>Series 32 and 38 of machines and vacuums don't need any adaptors as they all use 3" Camlock connections.</p>	<p>V25 SERIES TO L32 ELITE ELITE Part No: A71.00.00 X Part No: A71.00.00</p> <p>V25 SERIES TO L32 X ELITE Part No: A71.00.00 X Part No: A71.00.00</p> <p>LAVINA VACUUM MAIN HOSE (MH) V32 SERIES MAIN HOSE (both X and ELITE) V32GX-00.40.00 V25 SERIES MAIN HOSE (both X and ELITE) V25X-00.40.00 V20 X SERIES MAIN HOSE V20X-00.40.00 V20 ELITE SERIES MAIN HOSE V20E50.00.00</p> <p>IMPORTANT: We made it possible to connect a smaller vacuum to a larger machine (e.g. V20 with a L25) however, doing so will yield less satisfactory results. We strongly recommend using the same model group machine and vacuum, or a larger vacuum with a smaller machine (e.g. L25 with V25 or V32).</p>	<p>+ MH 2.5"</p> <p>Part No A73.00.00  Part No A71.00.00  Part No A71.00.00  Part No A71.00.00  Part No A71.00.00  Part No A71.00.00  Part No A71.00.00  Part No A71.00.00  Part No A71.00.00  Part No A71.00.00  Part No A71.00.00  Part No A71.00.00  Part No A71.00.00  Part No A71.00.00  Part No A71.00.00 </p>	 <p>L32,38 ELITE SERIES L32,38 X SERIES</p>											
		<p>PART DESCRIPTION TABLE</p> <table border="1"> <tr> <td>A70.00.00</td> <td>CAMLOCK ADAPTER 3inM-to-2inF</td> </tr> <tr> <td>A71.00.00</td> <td>CAMLOCK ADAPTER 3inM-to-2.5inF</td> </tr> <tr> <td>30316000116</td> <td>CAMLOCK ADAPTER 3inF-to-2inM</td> </tr> <tr> <td>A73.00.00</td> <td>CAMLOCK ADAPTER 3inF-to-2.5inM</td> </tr> <tr> <td>A76.00.00</td> <td>ADAPTER Ø50-to-2.5inF</td> </tr> <tr> <td>V25X-00.60.00</td> <td>ADAPTER 2.5inM-to-Ø50</td> </tr> </table>	A70.00.00	CAMLOCK ADAPTER 3inM-to-2inF	A71.00.00	CAMLOCK ADAPTER 3inM-to-2.5inF	30316000116	CAMLOCK ADAPTER 3inF-to-2inM	A73.00.00	CAMLOCK ADAPTER 3inF-to-2.5inM	A76.00.00	ADAPTER Ø50-to-2.5inF	V25X-00.60.00	ADAPTER 2.5inM-to-Ø50
A70.00.00	CAMLOCK ADAPTER 3inM-to-2inF													
A71.00.00	CAMLOCK ADAPTER 3inM-to-2.5inF													
30316000116	CAMLOCK ADAPTER 3inF-to-2inM													
A73.00.00	CAMLOCK ADAPTER 3inF-to-2.5inM													
A76.00.00	ADAPTER Ø50-to-2.5inF													
V25X-00.60.00	ADAPTER 2.5inM-to-Ø50													

11. LAVINA® V20GE SPARE PARTS

11.1 GENERAL PARTS

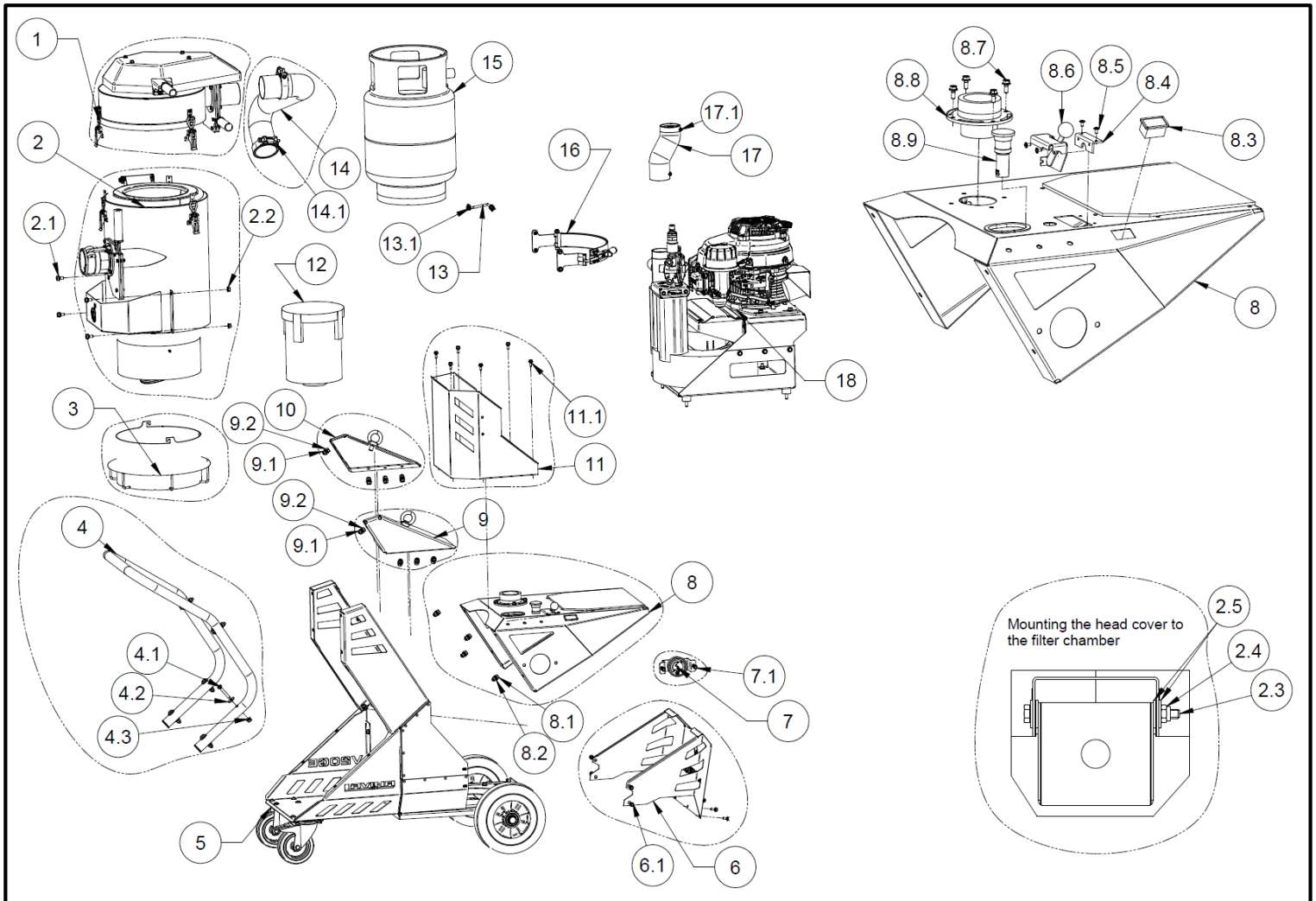

Figure 11.1

The strap pos.16 L25GS-25.00.00-1, replaces the old one L25GS-25.00.00.

LAVINA® V20GE GENERAL PARTS								
No.	Item No.	Description	Pcs.	No.	Item No.	Description	Pcs.	
1	V25GE30.00.00	Head cover assembly	1	8.7	30301210051	Bolt M6x16 DIN 6921	4	
2	V20E10.00.00	Filter chamber	1	8.8	V20GE02.10.00	HEPA chamber base	1	
2.1	30301210072	Bolt M8x16 DIN 6921	4	8.9	30311000717	EMG stop button	1	
2.2	30301240095	Nut M8 DIN 6923	4	9	V20GE03.00.00	Right lifting plate	1	
2.3	30301210166	Bolt M8x130 DIN 931	1	9.1	30301240095	Nut M8 DIN 6923	4	
2.4	30301240106	Nut M8 DIN 985	1	9.2	30301210072	Bolt M8x16 DIN 6921	4	
2.5	30301221019	Washer M8 DIN 9021	4	10	V20GE04.00.00	Left lifting plate	1	
3	VE10.00.00	Longopac bag holder	1	11	V25GE00.00.02	Propane tank holder	1	
4	V20GE05.00.00	Handle	1	11.1	30301210051	Bolt M6x16 DIN 6921	6	
4.1	30301210106	Bolt M8x50 DIN 933	6	12	30323000006-K	HEPA filter chamber kit	1	
4.2	30301221019	Washer M8 DIN 9021	6	12.1	30323000006	HEPA filter chamber + filter	1	
4.3	30301240095	Nut M8 DIN 6923	6	12.2	V25GE40.00.04	HEPA inlet elbow	1	
5	V20GE20.00.00	Carriage	1	13	V20GE00.00.04	Pressure hose	1	
6	V20GE01.00.00	Rear protective cover	1	13.1	30308000419	Clamp	2	
6.1	30301210051	Bolt M6x16 DIN 6921	7	14	V20GE00.00.02	Intermediate hose	1	
7	V20GE50.00.00	Vacuum gauge assembly	1	14.1	30308000408	Clamp	2	
7.1	30301210051	Bolt M6x16 DIN 6921	2	15	30313000318	Propane tank	1	
8	V20GE02.11.00-K	Control board-kit	1	16	L25GS-25.00.00-1	Strap	1	
8.1	30301240095	Nut M8 DIN 6923	4	17	V20GE00.00.03	Hose	1	
8.2	30301210072	Bolt M8x16 DIN 6921	4	17.1	30308000399	Clamp	2	
8.3	30313000172	Hour meter	1	18	V20GE40.00.00-K	Power unit kit	1	
8.4	L40G.24.00.02	Throttle plate	1	18.1	V20GE40.00.00	Power unit	1	
8.5	30301230039	Screw M4x8 ISO 7380F	4	18.2	30301240095	Nut M8 DIN 6923		
8.6	W4110	Throttle cable	1					

11.2 VACUUM HEAD COVER

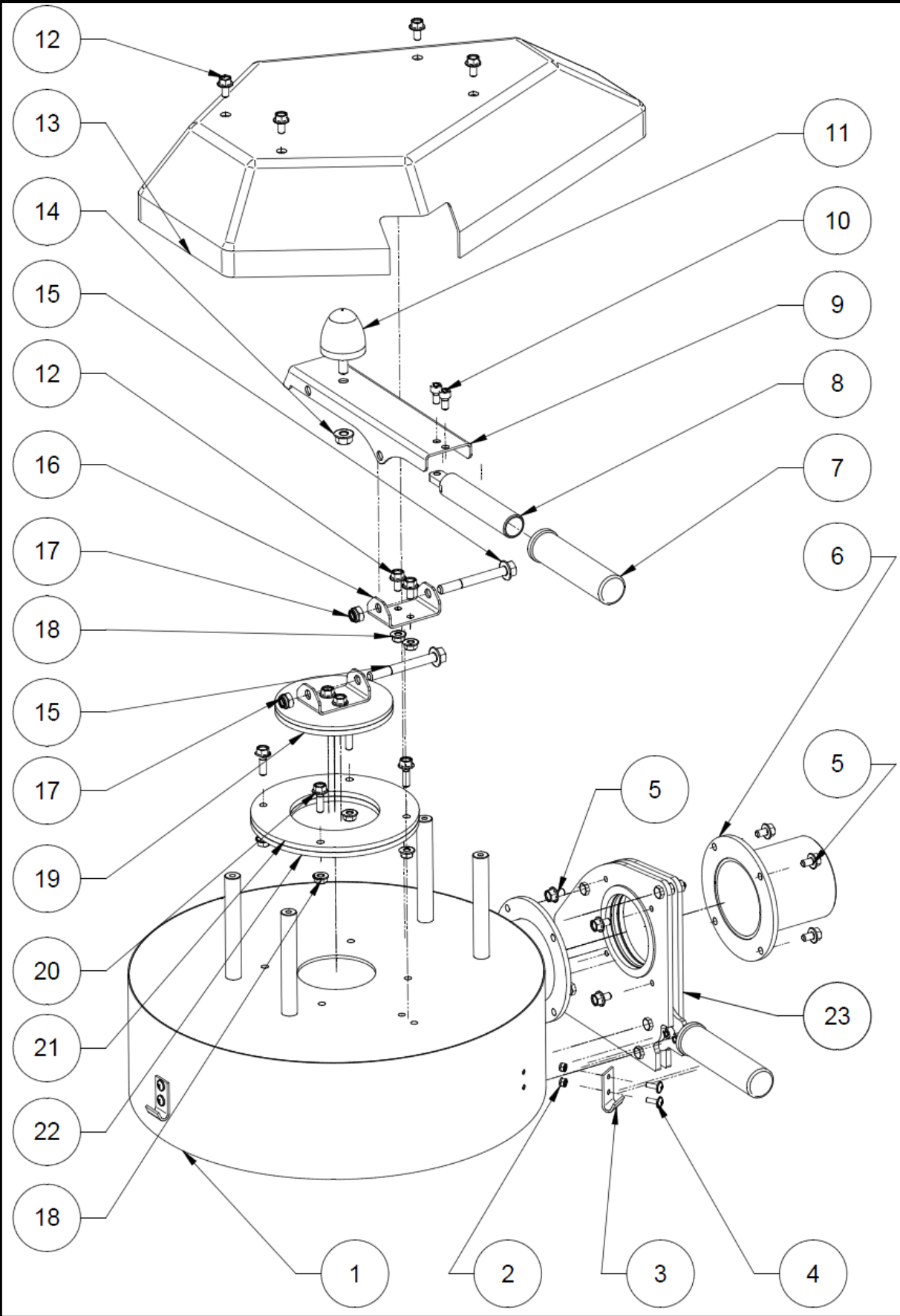
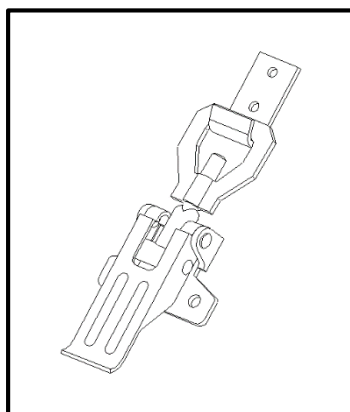
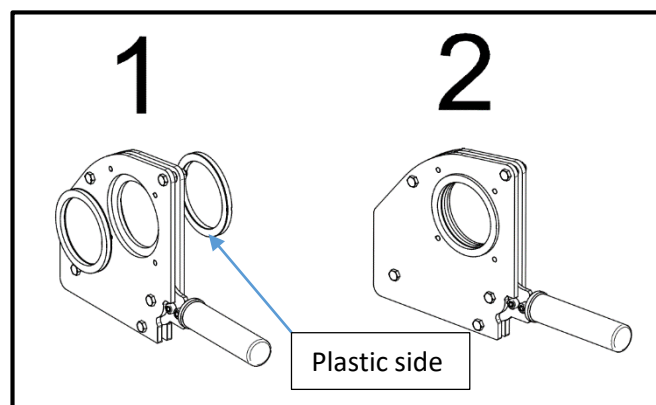

Figure 11.2

LAVINA® V20GE VACUUM HEAD COVER - V25GE30.00.00							
No.	Item No.	Description	Pcs.	No.	Item No.	Description	Pcs.
1	V25GE33.00.00	Vacuum head body	1	13	V25GE30.00.02	Top cover	1
2	30301240114	Nut M4 DIN 985	6	14	30301240095	Nut M8 DIN 6923	1
3	30329000040	Clamp set	3	15	30301210069	Bolt M8x70 DIN 6921	1
4	30301230066	Screw M4x12 DIN 967	6	16	V25GE30.00.01	Bearing plate	1
5	30301210043	Bolt M6x10 DIN 6921	8	17	30301240106	Nut M8 DIN 985	2
6	V25GE31.00.00	Outlet pipe	1	18	30301240098	Nut M6 DIN 6923	10
7	30329000014	Rubber handle	1	19	V25GE34.00.00	Valve plate assembly	1
8	V20X-14.10.00	Handle body	1	20	30301210117	Bolt M6x20 DIN 6923	4
9	V25GE30.00.05	Valve beam	1	21	V25GE32.00.01	Valve base plate	1
10	30301230048	Screw M6x12 DIN 912	2	22	V25GE30.00.04	Seal	1
11	30310000005	Buffer	1	23	V25GE11.00.00	Inlet valve assembly	1
12	30301210048	Bolt M6x12 DIN 6921	6				

Note:

1. The clamp set (No 3) contains the clamp and the attaching plate and they can't be ordered separately (fig. 10.2.1).
2. When mounting the inlet valve (pos.23) the bolts (pos. 5) must be tightened at 6 Nm.
3. Before mounting the inlet valve make sure both sealing rings are in position. The plastic side of the sealing must be in contact with the inlet valve (fig. 10.2.2).

**Figure 11.2.1****Figure 11.2.2**

11.3 MAIN FILTER CHAMBER

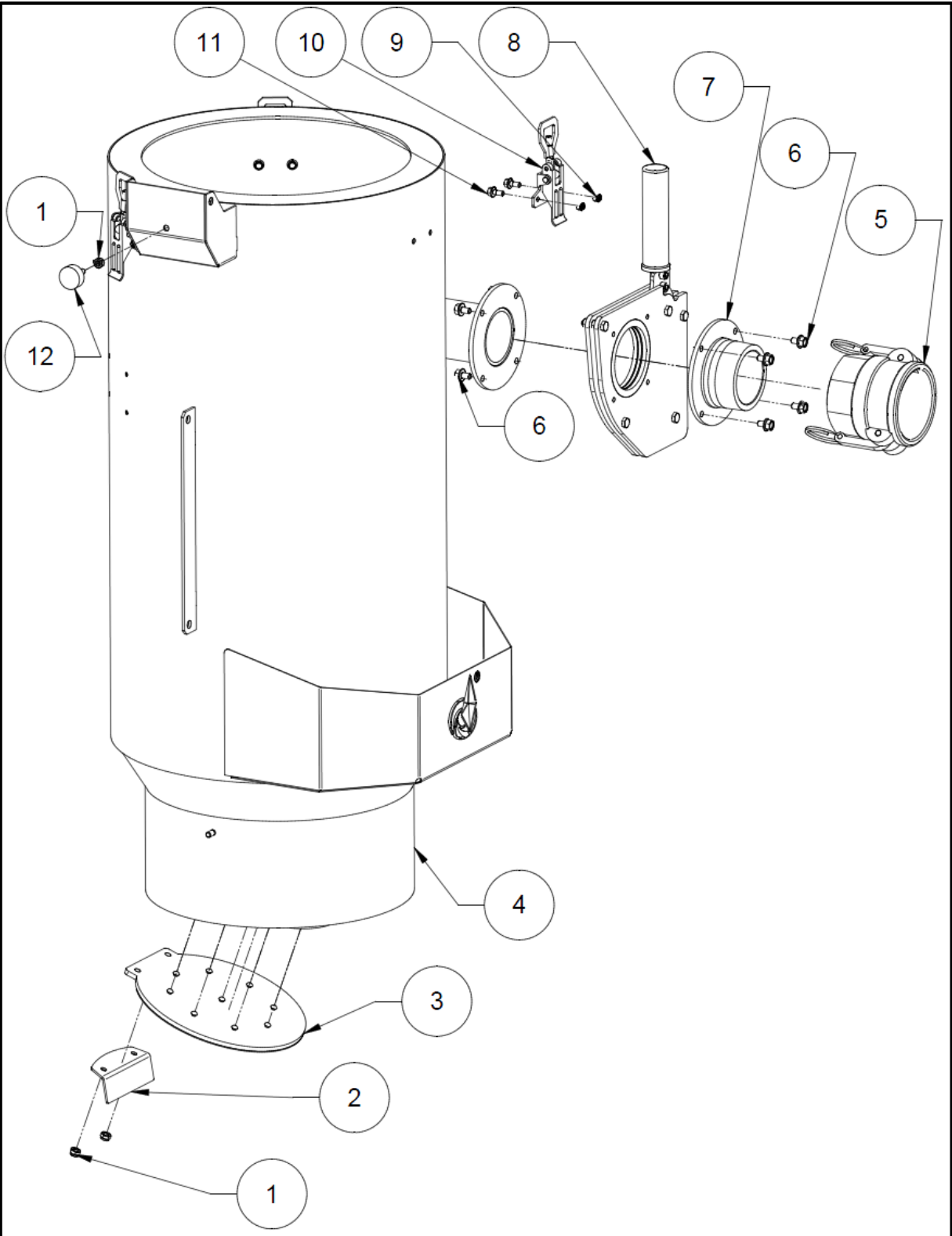

Figure 11.3

LAVINA® V20GE FILTER CHAMBER - V20E10.00.00							
No.	Item No.	Description	Pcs.	No.	Item No.	Description	Pcs.
1	30301240103	Nut M6 DIN 985	3	8	V25GE11.00.00	Inlet valve assembly	1
2	V25GE10.00.02	Flap restrictive plate	1	9	30301240110	Nut M5 DIN 982	6
3	V25GE14.00.00	Flap	1	10	Look at 11.2	Clamp set	3
4	V20E13.00.00	Filter chamber body	1	11	30301210030	Bolt M5x12 DIN 6921	6
5	D250-AL	Aluminum Camlock Fitting D250-AL	1	12	30310000010	Buffer	1
6	30301210043	Bolt M6x10 DIN 6921	8	13	V25GE-F-1	Main filter	1
7	V25X-13.00.00	Camlock D200 Flange	1				

The note from 11.2 applies here as well.

11.4 INLET VALVE

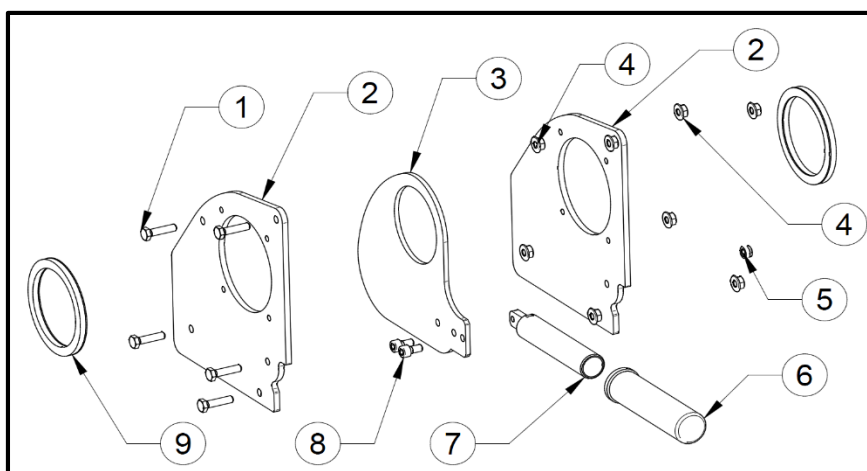

Figure 11.4

LAVINA® V20GE INLET VALVE - V25GE11.00.00-K							
No.	Item No.	Description	Pcs.	No.	Item No.	Description	Pcs.
1	30301210077	Bolt M6x25 DIN 933	5	6	30329000014	Rubber handle	1
2	V25GE11.00.02	Inlet valve flange	2	7	V20X-14.10.00	Handle body	1
3	V25GE11.00.01	Inlet valve plate	1	8	30301230048	Screw M6x12 DIN 912	2
4	30301240098	Nut M6 DIN 6923	8	9	V25GE12.00.00	Sealing ring	2
5	30301240103	Nut M6 DIN 985	1	10			

11.5 CARRIAGE

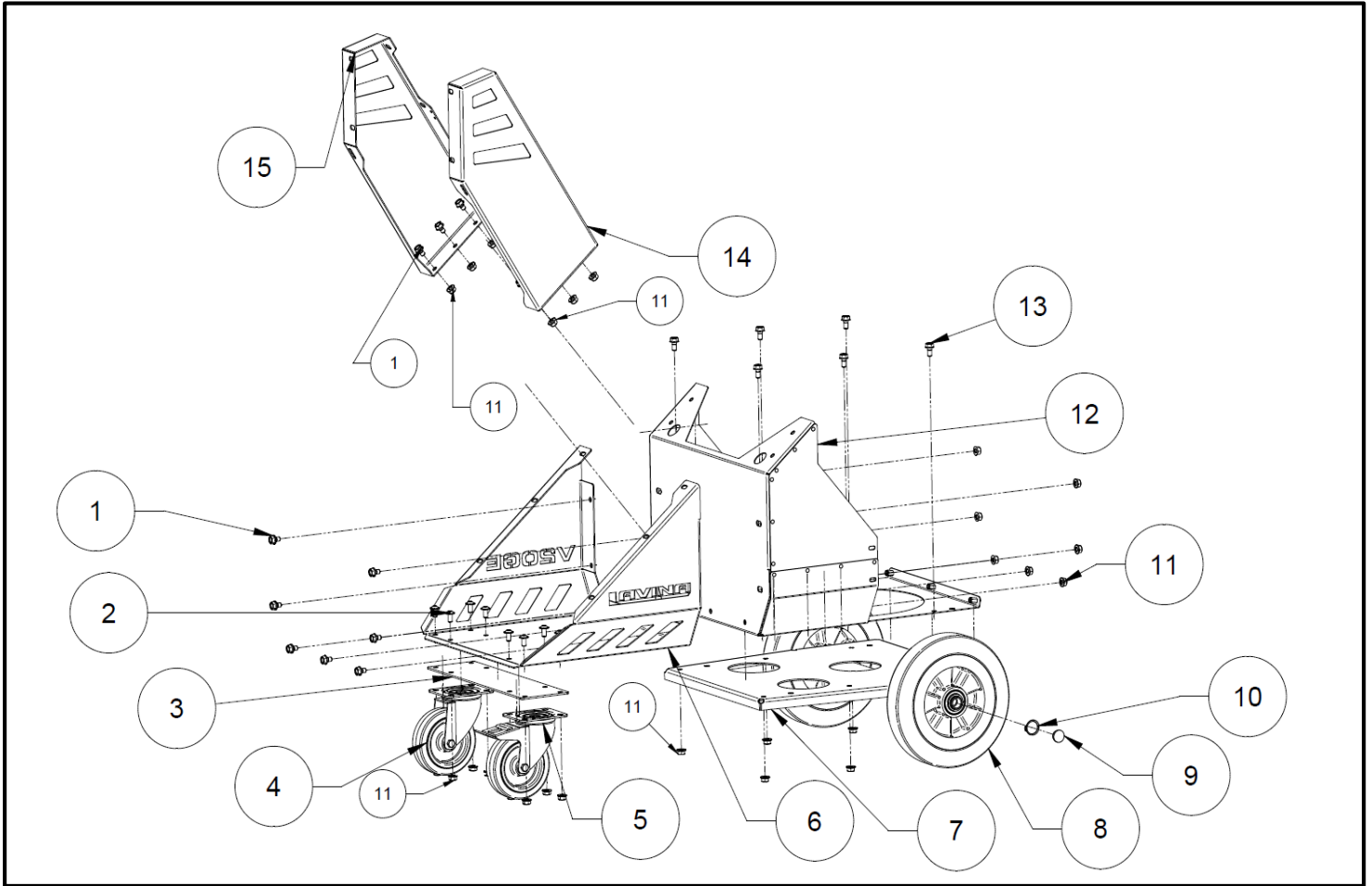

Figure 11.5

LAVINA® V20GE CARRIAGE - V20GE20.00.00-K								
No.	Item No.	Description	Pcs.	No.	Item No.	Description	Pcs.	
1	30301210058	Bolt M8x12 DIN 6921	13	9	40401000112	Plastic cap	2	
2	30301230209	Screw M8x16 ISO 7380F	8	10	30301250036	Circlip B25x1.5 A2 DIN471	2	
3	V20GE20.00.02	Reinforcing plate	1	11	30301240095	Nut M8 DIN 6923	27	
4	30312000047	Caster wheel	1	12	V20GE21.00.00	Rear base	1	
5	30312000046	Caster locking wheel	1	13	30301210072	Bolt M8x16 DIN 6921	6	
6	V20GE20.00.01	Front base	1	14	V20E20.00.02	Right filter chamber holder	1	
7	V20GE22.00.00-1	Wheel holder	1	15	V20E20.00.01	Left filter chamber holder	1	
8	30312000004	Wheel	2					

11.6 VACUUM GAUGE ASSEMBLY

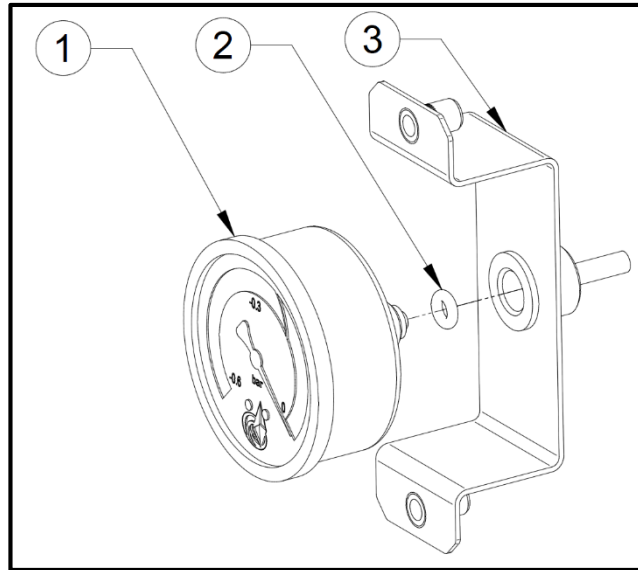

Figure 11.6

LAVINA® V20GE VACUUM GAUGE ASSEMBLY			
No.	Item No.	Description	Pcs.
1	30313000187	Vacuum gauge	1
2	30302000131	Sealing	1
3	V25GE50.10.00	Vacuum gauge base plate	1

11.7 POWER UNIT

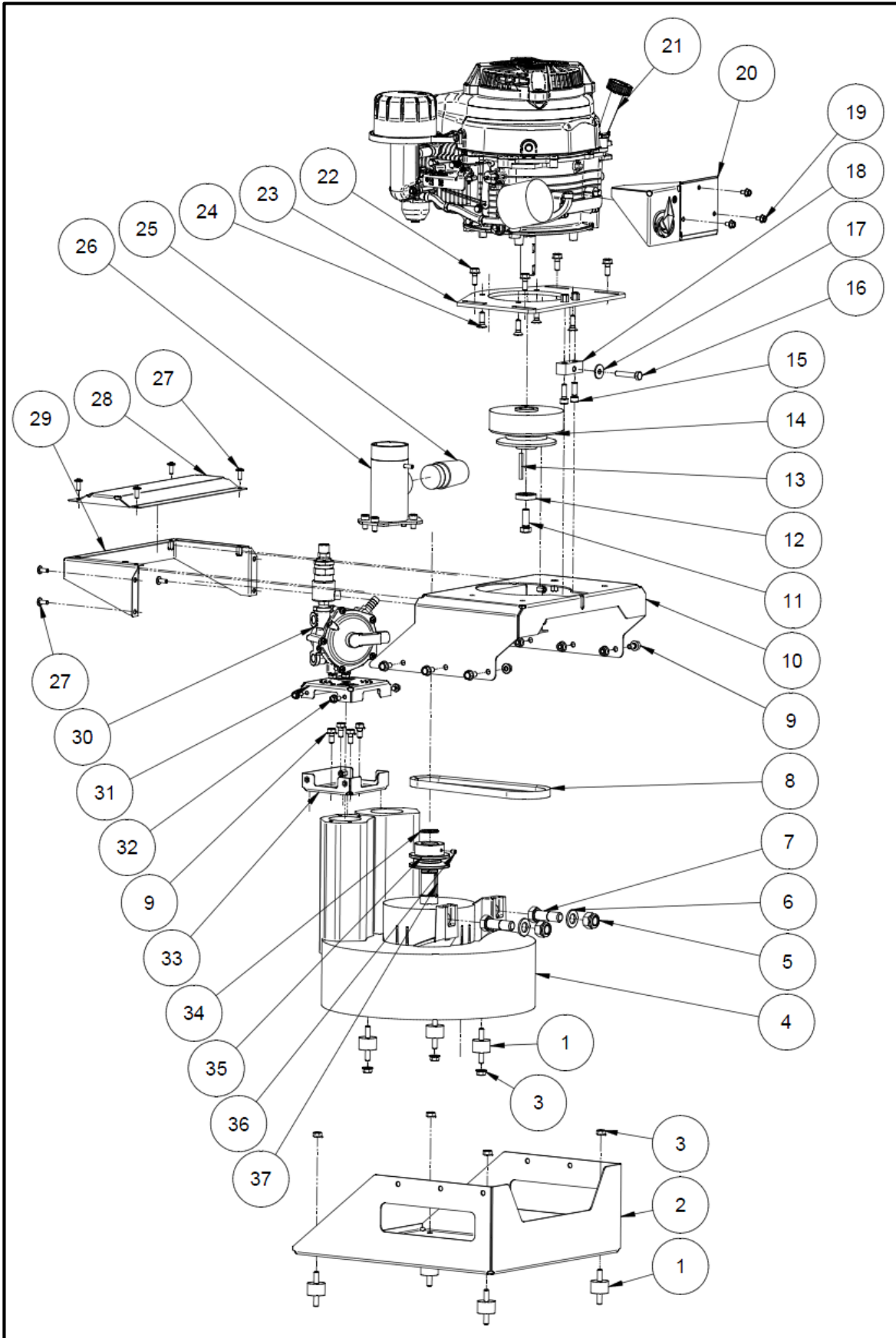

Figure 11.7

LAVINA® V25GE POWER UNIT							
No.	Item No.	Description	Pcs.	No.	Item No.	Description	Pcs.
1	30310000004	Buffer	7	23	V20GE42.00.00	Motor base plate	1
2	V20GE40.00.01	Blower base plate	1	24	30301230027	Screw M8x25 DIN 7991	4
3	30301240095	Nut M8 DIN 6923	13	25	30316000077	Relief valve	1
4	30305000412	Blower	1	26	V20GE43.00.00-K	Inlet air pipe kit	1
5	30301240109	Nut M16 DIN 982	2	26.1	V20GE43.00.00	Inlet air pipe	1
6	30301221008	Washer M15 DIN 125A	2	26.2	30301230018	Screw M6x16 DIN 912	4
7	30301210146	Bolt M16x50 DIN 933	2	26.3		Seal	1
8	30308000170	Belt	1	27	30301230243	Screw M6x16 ISO 7380F	8
9	30301210072	Bolt M8x16 DIN 6921	10	28	V20GE40.00.04	Protective cover	1
10	V20GE41.00.00	Motor carrier plate	1	29	V20GE44.00.00	Protective cover base	1
11		"Болт 7/16-20 UNF x 1 1/4""	1	30	V25GE00.60.00	Regulator set	1
12	L13GX10.00.08	Washer	1	31	V20GE40.00.03	Regulator base plate top	1
13	L13GX10.00.10	Key	1	32	30301210051	Bolt M6x16 DIN 6921	4
14	30313000326	Centrifugal clutch	1	33	V20GE45.00.00	Regulator base plate bottom	1
15	30301230004	Screw M8x25 DIN 912	2	34	30301250028	Circlip B28x1.5 DIN 471	1
16	30301210078	Bolt M8x45 DIN 933	1	35	V20GE40.00.02	Pulley	1
17	30301221019	Washer M8 DIN 9021	1	36	30301230145	Screw M6x8 DIN 913	1
18	L25G-10.00.66	Tensioning device support	1	37	30301260066	Key	1
19	30301210043	Bolt M6x10 DIN 6921	3				
20	V20GE40.00.05	Oil filter cover	1				
21	FJ180V KAI	Kawasaki FJ180V KAI	1				
22	30301210031	Bolt M8x20 DIN 6921	4				

12. ACCESSORIES



Figure 12.1



Figure 12.2

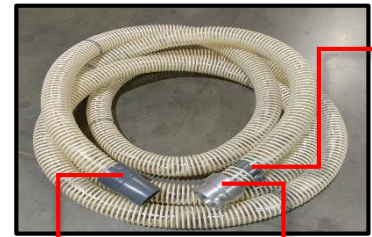

Figure 12.3

3.1

3.3

3.2



Figure 12.4



Figure 12.5



Figure 12.6

ACCESSORIES					
No.	Item No.	Description	Pcs.	Fig.	
1	30310000104	Floor Brush combo 18 in L-FB-50	1	12.1	
2	30316000062	Steel wand L-A-50	1	12.2	
3	V20E50.00.00	Main vacuum hose with CAMLOCK and cuff	1	12.3	
	3.1	30316000063	Cuff L-R-C-1	1	
	3.2	V25X-00.51.00	Vacuum fitting D250	1	
	3.3	30308000399	Clamp 50_70DIN3017	1	
	3.4	D50x7.5	Vacuum Hose	1	
4	V20E-F-2	Main filter	1	12.4	
5	V25GE-FH-1	HEPA filter	1	12.5	
6	V-S-L-1	Longopack bag	1	12.6	
CAMLOCK ADAPTERS					
1	A70.00.00	3''M-to-2''F	1		
2	A71.00.00	3''M-to-2.5''F	1		
3	A73.00.00	3''F-to-2.5''M	1		
4	30316000116	3''F-to-2''M	1		
5	V25X-00.60.00	Adapter 2.5'' MALE CAMLOCK with Ø51 Hole with seals to fit with the steel wand, L20 ELITE SERIES and all X SERIES machines.	1		

13. DISPOSAL

If your machine after time is not usable or needs to be replaced, send the machine back to Superabrasive or a local distributor, where a professional disposal complying with the environment laws and directives is guaranteed.

14. MANUFACTURER'S CONTACTS

If you need to contact Superabrasive Inc. with technical support questions, below is the contact information.

Address: 9411 Jackson Trail Road, Hoshton GA 30548, USA

Email: info@superabrasive.us

Tel.: 706 658 1122

Fax: 706 658 0357

Website: www.superabrasive.com

15. CE-RECERTIFICATION

All LAVINA® dust collectors are designed to operate correctly in an electromagnetic atmosphere of industrial type, and are equipped with all of the mechanical and electrical safety protections in conformity with the following European CEE rules and regulations:

LAVINA® Vacuums comply with the Safety Directive for machines 2006/42/EC, the EMC Directive 2004/108/EC and the Low Voltage Directive 2006/95/EC.

They also comply with the norms in use UNI EN 13857, CEI EN 60204-1, CEI EN 61000-3-2, CEI EN 61000-3-3, CEI EN 55014.

Test results are a part of the machine's technical information and can be provided upon request. The vacuum unit machine is delivered with the CE mark exposed and is provided with a EC declaration of conformity.

16. EMISSION CONTROL WARRANTY STATEMENT

CALIFORNIA EMISSION CONTROL WARRANTY STATEMENT YOUR WARRANTY RIGHTS AND OBLIGATIONS

The California Air Resources Board and Superabrasive Inc. are pleased to explain the emissions control system warranty on your 2016 small off-road engine (SORE). In California, new SORE must be designed, built and equipped to meet the State's stringent anti-smog standards. Superabrasive Inc. must warrant the emission control system on your SORE for the period of time listed below provided there has been no abuse, neglect or improper maintenance of your SORE.

Your emission control system may include parts such as the carburetor, fuel-injection system, the ignition system, catalytic converter, fuel tanks, fuel lines, fuel caps, valves, canisters, filters, vapor hoses, clamps, connectors, and other associated emission-related components.

Where a warrantable condition exists, Superabrasive Inc. will repair your SORE at no cost to you including diagnosis, parts and labor.

MANUFACTURER'S WARRANTY COVERAGE

The emission control system is warranted for 2 years. If any emission-related part on your equipment is defective, the part will be repaired or replaced by Superabrasive Inc.

OWNER'S WARRANTY RESPONSIBILITIES

As the small off-road engine (SORE) owner, you are responsible for the performance of the required maintenance listed in your owner's manual. Superabrasive Inc. recommends that you retain all receipts covering maintenance of your SORE engine, but Superabrasive Inc. cannot deny warranty solely for the lack of receipts or for your failure to ensure the performance of all scheduled maintenance.

As the SORE owner you should however be aware that Superabrasive Inc. may deny your warranty if your SORE or its part has failed due to abuse, neglect, improper maintenance or unapproved modification.

You are responsible for presenting your utility equipment engine to a Superabrasive Inc. distribution center as soon as the problem exists. The warranty repairs should be completed within a reasonable amount of time, not to exceed 30 days. If you have any questions regarding your warranty rights and responsibilities, you should contact Superabrasive Inc. at 1-(800)-987-8403 or by e-mail at info@superabrasive.us

Superabrasive Inc

9411 Jackson trail Rd

Hoschton, GA

USA, 30548

GENERAL EMISSIONS WARRANTY COVERAGE

Superabrasive Inc. warrants to the ultimate purchaser and each subsequent purchaser that the equipment is:

Designed, built and equipped so as to conform with all applicable regulations; and

Free from defects in materials and workmanship that cause the failure of a warranted part to be identical in all material respects to that part as described in Superabrasive Inc. application for certification.

The warranty period begins on the date the equipment is delivered to an ultimate purchaser or first placed into service. The warranty period is two years.

Subject to certain conditions and exclusions as stated below, the warranty on emission-related parts is as follows:

(1) Any warranted part that is not scheduled for replacement as required maintenance in the written instructions supplied, is warranted for the warranty period stated above. If the part fails during the period of warranty coverage, the part will be repaired or replaced by Superabrasive Inc. according to subsection (4) below. Any such part repaired or replaced under warranty will be warranted for the remainder of the period.

(2) Any warranted part that is scheduled only for regular inspection in the written instructions supplied is warranted for the warranty period stated above. Any such part repaired or replaced under warranty will be warranted for the remaining warranty period.

(3) Any warranted part that is scheduled for replacement as required maintenance in the written instructions supplied is warranted for the period of time before the first scheduled replacement date for that part. If the part fails before the first scheduled replacement, the part will be repaired or replaced by Superabrasive Inc. according to subsection (4) below. Any such part repaired or replaced under warranty will be warranted for the remainder of the period prior to the first scheduled replacement point for the part.

(4) Repair or replacement of any warranted part under the warranty provisions herein must be performed at a warranty station at no charge to the owner.

(5) Notwithstanding the provisions herein, warranty services or repairs will be provided at all of our distribution centers that are franchised to service the subject engines or equipment.

(6) The SORE owner will not be charged for diagnostic labor that is directly associated with diagnosis of a defective, emission-related warranted part, provided that such diagnostic work is performed at a warranty station.

(7) Superabrasive Inc. is liable for damages to other engine or equipment components proximately caused by a failure under warranty of any warranted part.

(8) Throughout the SORE warranty period stated above, Superabrasive Inc. will maintain a supply of warranted parts sufficient to meet the expected demand for such parts.

(9) Any replacement part may be used in the performance of any warranty maintenance or repairs and must be provided without charge to the owner. Such use will not reduce the warranty obligations of Superabrasive Inc.

(10) Add-on or modified parts that are not exempted by the Air Resources Board may not be used. The use of any non-exempted add-on or modified parts by the ultimate purchaser will be grounds for disallowing a warranty claims. Superabrasive Inc. will not be liable to warrant failures of warranted parts caused by the use of a non-exempted add-on or modified part.

WARRANTED PARTS

The repair or replacement of any warranted part otherwise eligible for warranty coverage may be excluded from such warranty coverage if Superabrasive Inc. demonstrates that the SORE has been abused, neglected, or improperly maintained, and that such abuse, neglect, or improper maintenance was the direct cause of the need for repair or replacement of the part. That notwithstanding, any adjustment of a component that has a factory installed, and properly operating, adjustment limiting device is still eligible for warranty coverage. The following emission warranty parts are covered:

- (1)Catalytic converter
- (2)Fuel system: Carburetor, pressure regulator and fuel lock off
- (3)Ignition system
- (4)Intake system including pre-filter
- (5)Exhaust manifold