

<b>Length (A)</b> inches (mm)	<b>Width (B)</b> inches (mm)	<b>Height (C)</b> inches (mm)
8 <sup>7</sup> / <sub>16</sub> (214)	7 <sup>1</sup> / <sub>4</sub> (184)	15 <sup>1</sup> / <sub>8</sub> (385)

<b>Grip Range (D)</b> inches (mm)	<b>Net weight</b> lbs (kg)	<b>WLL*</b> lbs (kg)
<sup>3</sup> / <sub>8</sub> ~ 1 <sup>15</sup> / <sub>16</sub> (10 ~ 50)	51.8 (23.5)	2860 (1300)

\* WLL: Work load limit

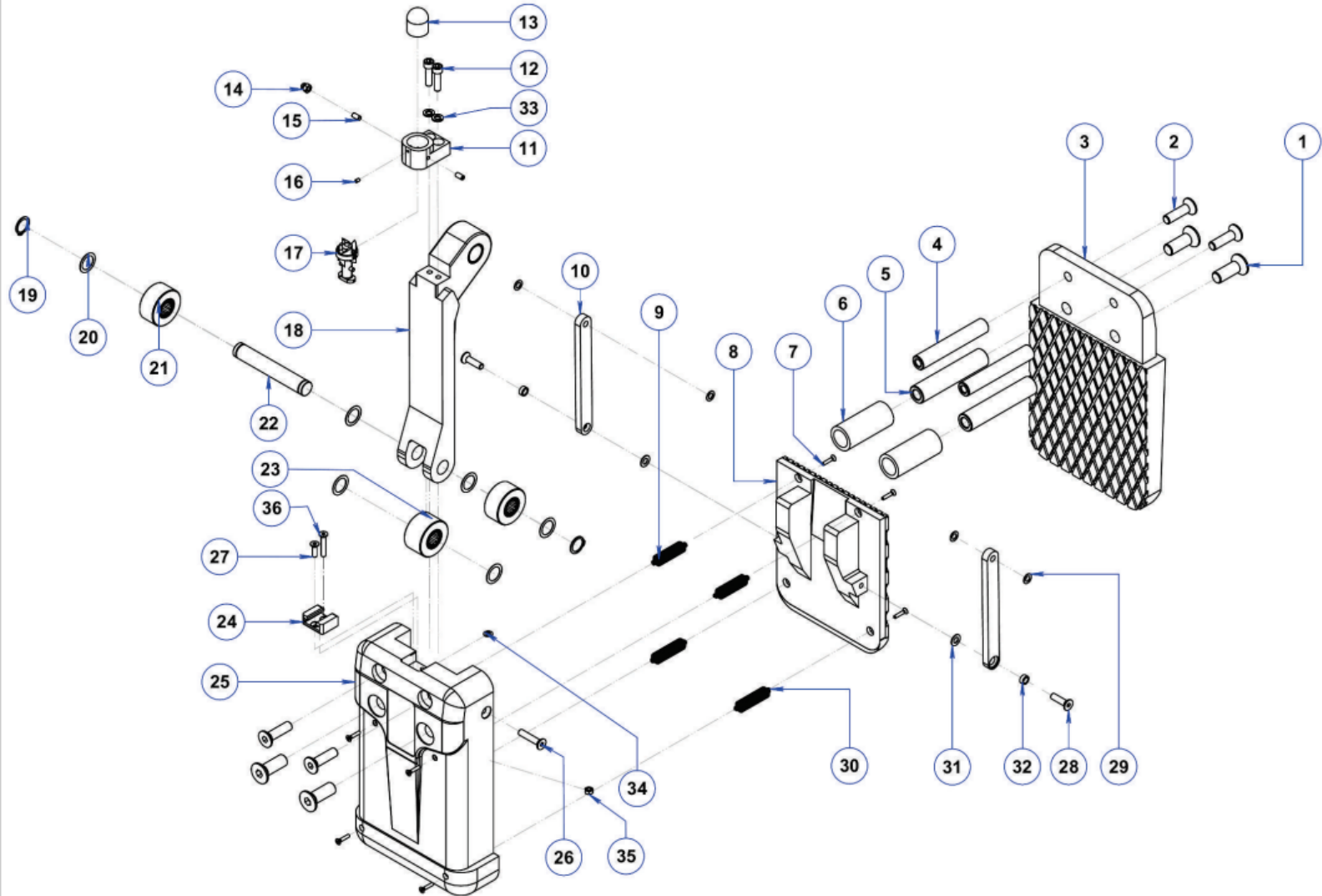













## 2) SPARE PART LIST:

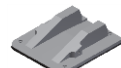

# SPARE PART LIST

**Name: ABACO LITTLE GIANT LIFTER AUTOMATIC**

**Model: ALG50A**

Code	Description	Image	Unit	Qty.
ALG50A-01	Allen bolt countersunk M16 x 50		pcs	4
ALG50A-02	Allen bolt countersunk M12 x 40		pcs	4
ALG50A-03	Clamp back plate		pcs	1
ALG50A-04	Top pin		pcs	2
ALG50A-05	Bottom pin		pcs	2
ALG50A-06	Rubber tube		pcs	2
ALG50A-07	Screw M4 x 20		pcs	8
ALG50A-08	Clamp center plate		pcs	1
ALG50A-09	Top extension spring		pcs	2
ALG50A-10	Linker		pcs	2
ALG50A-11	Base, auto lock		pcs	1
ALG50A-12	Allen bolt M8 x 30		pcs	2
ALG50A-13	Cover		pcs	1
ALG50A-14	Cap nut M6		pcs	2
ALG50A-15	Allen set screw M6 x 12		pcs	2

ALG50A-16	Allen set screw M4 x 6		pcs	1
ALG50A-17	Automatic locking latch		set	1
ALG50A-18	Lifting pin		pcs	1
ALG50A-19	Circlip Ø20		pcs	2
ALG50A-20	Brass washer Ø20		pcs	6
ALG50A-21	Outer roller		pcs	2
ALG50A-22	Shaft of roller		pcs	1
ALG50A-23	Inner roller		pcs	1
ALG50A-24	Receptacle (automatic lock)		pcs	1
ALG50A-25	Main housing		pcs	1
ALG50A-26	Allen bolt countersunk M8 x 40		pcs	2
ALG50A-27	Allen bolt countersunk M6 x 20		pcs	1
ALG50A-28	Allen bolt countersunk M8 x 30		pcs	2
ALG50A-29	Aluminum washer Ø8		pcs	4
ALG50A-30	Bottom extension spring		pcs	2
ALG50A-31	Washer Ø8		pcs	2
ALG50A-32	Spacer		pcs	2
ALG50A-33	Spring washer Ø8		pcs	2
ALG50A-34	Washer Ø6		pcs	1

ALG50A-35	Nut M6		pcs	1
ALG50A-36	Allen bolt countersunk M6x40		pcs	1
	Swivel Shackle		pcs	1