

SINKITS SLOT-CLIP FACT SHEET

TOP BOLT: REQUIRES 7/16" DRIVER. TIGHTEN AGAINST SINK RIM TO COMPLETE INSTALLATION. DO NOT OVER-TIGHTEN.

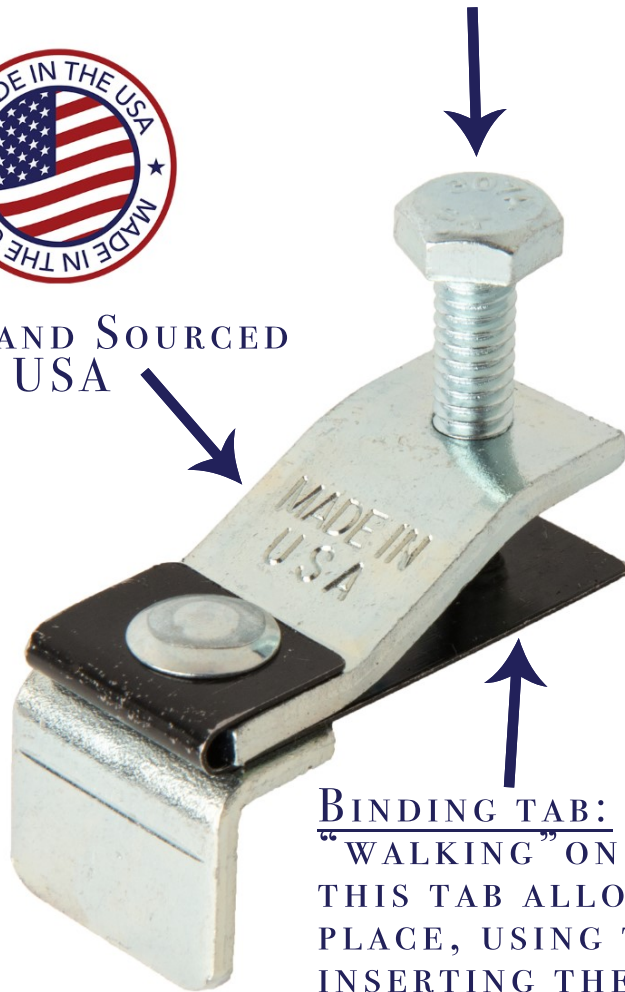

MADE AND SOURCED
IN THE USA



SAVES TIME,
CREATING PROFIT;
EVEN WITH A LOW
VOLUME OF SINK
INSTALLATIONS

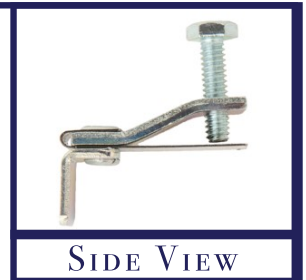

SIDE VIEW

REDUCES ERRORS AND
CALL-BACKS

NO ADHESIVES OR EPOXY

EASILY SUPPORT HUNDREDS OF
POUNDS

ZINC TRIVALENT COATING

BINDING TAB: PREVENTS THE TOP BOLT FROM "WALKING" ON THE SINK RIM DURING TIGHTENING. THIS TAB ALLOWS FOR THE CLAMP TO STAY IN PLACE, USING THE WEIGHT OF THE SINK, AFTER INSERTING THE ANCHOR POST. IT MUST BE BENT FAR ENOUGH TO CREATE PRESSURE WHEN INSERTING.

ANCHOR POST: SLOT-CLIPS CAN BE USED ON UP TO 5/8" SINK RIMS.

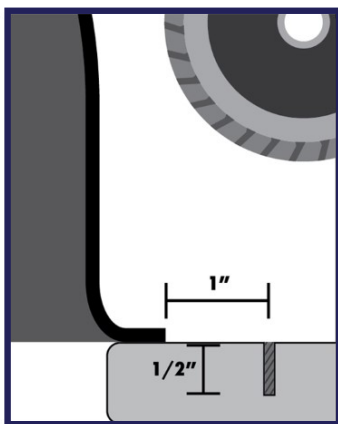

SLOT SPECIFICATIONS: USING AN APPROPRIATE BLADE, CUT A SLOT AT LEAST 1/2" DEEP, 1" FROM THE EDGE OF THE SINK RIM.

INSTALLATION VIDEOS AVAILABLE AT: WWW.SINKITS.COM